



PRODUCT SPECIFICATIONS

Bulletin No. 210000
 October 2011
 Supersedes June 2011



Front View



Tubular Heat Exchanger

Thermal Efficiency - up to 80.5%
Input - 100,000 to 390,000 Btuh

MODEL NUMBER IDENTIFICATION

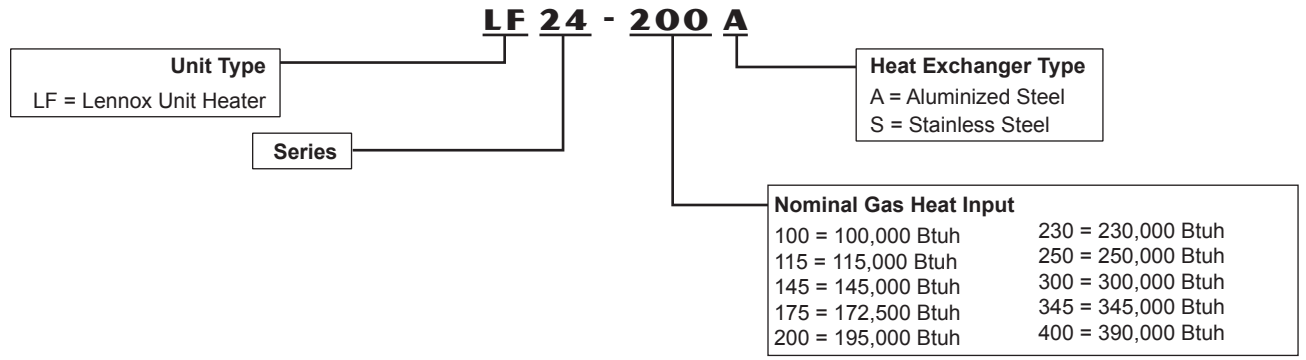

FEATURES AND BENEFITS

CONTENTS

Dimensions7
 Electrical Data.....4
 Features And Benefits1
 Guide Specifications.....10
 High Altitude Derate.....6
 Installation Clearances6
 Maximum Horizontal Vent Lengths.....6
 Model Number Identification.....1
 Optional Accessories4
 Specifications.....4
 Vent Kits And Accessories9

WARRANTY

Heat exchanger - stainless steel - fifteen year limited warranty, aluminized steel - ten year limited warranty.
All other covered components - one year limited warranty.
 Refer to Lennox Equipment Limited Warranty certificate included with equipment for details.

FEATURES AND BENEFITS

APPLICATIONS

Lennox LF24 gas-fired, horizontal unit heaters are compact in design and easy to install.

Units feature steady-state heating efficiencies of up to 80.5%.

LF24 unit heaters are ideal for economical commercial heating systems.

Units are shipped completely assembled with controls factory installed and wired.

In addition, each unit is test operated at the factory to ensure proper operation and dependability.

Installer has only to locate unit, make unit gas supply, flue, electrical connections and mount thermostat to complete the installation.

Units may be vented horizontally or vertically.

APPROVALS

Units are certified by CSA International.

Listed by the California Energy Commission (CEC).

Units are certified for natural or LPG/Propane gas.

ISO 9001 Registered Manufacturing Quality System.

HEATING SYSTEM

24 volt redundant combination gas control valve combines a manual main shutoff valve, pressure regulation and automatic electric valve (dual) into one compact combination control.

Electronic direct spark ignition control provides positive and safe main burner ignition.

Spark is intermittent and occurs only when required.

Separate electronic flame sensor control assures safe and reliable operation.

Should loss of flame occur, flame sensor controls will initiate 3 attempts at re-ignition before locking out unit operation.

Combustion air inducer prepurges heat exchanger and safely vents flue products.

Pressure switch proves combustion air inducer operation before allowing gas valve to open.

Combustion air inducer operates only during heating cycle.

Tubular Aluminized or Stainless Steel Heat Exchanger

Tubular heat exchanger is constructed of aluminized or stainless steel for superior resistance to corrosion and oxidation.

Curving design allows complete exposure of heating surfaces to supply air stream.

Round surfaces create minimum air resistance and allow air to surround all surfaces for excellent heat transfer.

Compact design reduces space requirements in unit cabinet.

Heat exchanger has been laboratory life cycle tested.

Inshot Burners

Aluminized steel inshot burners provide efficient trouble free operation.

Burner venturi mixes air and gas in correct proportion for proper combustion.

Burner assembly is removable from the unit as a single component for ease of service. Each burner may be removed individually.

Limit Control

Factory installed and accurately located.

Limit control has fixed temperature setting and protects heating system from abnormal operating conditions.

Combustion Air Inducer

Combustion air inducer prepurges heat exchanger and safely vents combustion products.

Blower motor has sleeve bearings and is thermally protected.

Pressure switch prevents unit operation in case of blockage of combustion air inlet or flue outlet.

Combustion air inducer on LF24-100, -115, -125, -145 units may be rotated 90° to left or right of vertical to facilitate installation.

OPTIONS/ACCESSORIES

LPG/Propane Conversion Kit

Conversion kit is required for field changeover from natural gas.

Kit is not furnished and must be ordered extra.

FEATURES AND BENEFITS

VENTING

Units may be vented horizontally or vertically.

Vertical Venting - LF24 units are approved for installation with single wall and type B-1 double wall vent pipe.

Horizontal Venting - LF24 units are approved for installation with single wall or Lennox-approved stainless steel vent kits.

OPTIONS/ACCESSORIES

Horizontal Vent Kits

UL listed, Cat III stainless steel vent kits are available for upward or downward slope. 4 to 5 in. vent kits snap together, 6 in. vent kit include connection clamps.

Kits include unit transition, vent termination and wall thimble. Upward slope kits have drain connection, 5 in. downward slope kits have double male adaptor. Provisions for hanging kits must be field supplied.

45° or 90° elbow is available and required for certain size units where the combustion air inducer cannot be rotated 90°.

Straight pipe sections in various lengths are also available.

See Horizontal Vent Kits / Elbow table for Lennox-approved Horizontal Vent Kits and accessories.

See drawings for additional information.

See installation instructions for detailed venting requirements.

CONTROLS

Includes: 24 volt main gas valve with 100% safety shutoff, main shutoff valve, gas pressure regulation (natural & LPG/propane gas models), limit control, transformer and combination ignition/fan timer control board.

Combination Direct Spark Ignition/Fan Timer Control

Control board contains all necessary controls and relays to operate unit.

Includes: Fan timer control - fan on 45 seconds (fixed), fan off 150 seconds (fixed), terminal strip for thermostat connections, diagnostic LED for troubleshooting, continuous fan operation.

Transformer

120V/24V transformer furnished as standard.

OPTIONS

Thermostat

See Thermostat bulletins in Controls section and Lennox Price Book for a complete list of thermostats.

DIRECT DRIVE FAN

All models are equipped with efficient and quiet operating direct drive fan.

CABINET

Constructed of heavy gauge painted steel.

Inside cabinet insulation keeps outer cabinet surface temperatures low.

Adjustable louvers are furnished on cabinet for control of air flow direction.

Wiring junction box is conveniently located on outside of cabinet for easy access. Box contains all electrical and safety controls.

Terminal strip provided for thermostat connections.

3/8" x 16 rivetnuts are located on the top of cabinet for suspending unit. See dimension drawing.

OPTIONS

Discharge Nozzles

To direct discharge air from unit heater.

Available in 30°, 45°, 60° and 90° style.

Fully assembled from heavy-gauge steel.

Paint finish matches unit heater.

See Dimension Drawings.

Hanging Bracket Kit

Used to suspend unit heaters on two pipe hangers.

Kit contains two brackets and all necessary hardware.

Pipe hangers (3/4 in.) are not furnished and must be field provided.

SPECIFICATIONS - LF24-100 TO LF24-200

Gas Heating Performance	Model No. - Stainless Steel	LF24-100S	LF24-115S	LF24-145S	LF24-175S	LF24-200S
	Model No. - Aluminized Steel	LF24-100A	LF24-115A	LF24-145A	LF24-175A	LF24-200A
	Heating Capacity Input - Btuh	100,000	115,000	145,000	172,500	195,000
	Output - Natural - Btuh	80,500	92,000	116,000	138,000	156,000
	Steady State Efficiency - Natural	80.5%	80.0%	80.0%	80.0%	80.0%
Connections	Flue size - in. (round)	¹ 4	¹ 4	¹ 4	² 5	² 5
	Gas Piping Size	1/2	1/2	1/2	1/2	1/2
Fan Data	Air Volume - cfm	1900	1900	1900	2200	2200
	Number of Fans	1	1	1	1	1
	Diameter - in.	16	16	16	16	16
	Number of blades	4	4	4	4	4
	Number of Motors	1	1	1	1	1
	Motor Output - hp	1/8	1/8	1/8	1/8	1/8
	RPM	1075	1075	1075	1075	1075
Weight Data	Net Weight - lbs.	125	125	130	145	145
	Shipping Weight - lbs.	140	140	150	165	165

ELECTRICAL DATA

Line voltage data - 60hz	115 volts - 1 phase				
Motor amps	2.1	2.1	2.1	2.1	2.1
Total unit amps	6.0	6.0	6.0	6.0	6.0

OPTIONAL ACCESSORIES - MUST BE ORDERED EXTRA

Discharge Nozzle	30° - 94K94	•	•	•		
	94K95				•	•
	45° - 94K98	•	•	•		
	94K99				•	•
	60° - 16L28	•	•	•		
	16L29				•	•
	90° - 15L96	•	•	•		
	15L97				•	•
Hanging Bracket Kit	87277	•	•	•	•	•
High Altitude Pressure Switch Kit	36W49	³ •	³ •	³ •	⁴ •	- - -
LPG/Propane Kit	45L85	•				
	63J56		•	•	•	
	20L07					•
	63J57					

¹ 2-1/8 x 4 in. diameter adaptor is furnished with unit for flue connection.

² 2-1/4 x 2-3/4 in. rectangular to 5 in. round adaptor is furnished with unit for flue connection.

³ LF24-100 through -145 models - Combustion air inducer pressure switch must be replaced at altitudes over 5500 ft.

⁴ LF24-175 model - Combustion air inducer pressure switch must be replaced at altitudes over 2500 ft.

SPECIFICATIONS - LF24-230 TO LF24-400

Gas Heating Performance	Model No. - Stainless Steel	LF24-230S	LF24-250S	LF24-300S	LF24-345S	LF24-400S
	Model No. - Aluminized Steel	LF24-230A	LF24-250A	LF24-300A	LF24-345A	LF24-400A
	Heating Capacity Input - Btuh	230,000	250,000	300,000	345,000	390,000
	Output - Natural - Btuh	184,000	201,250	241,500	276,000	312,000
	Steady State Efficiency - Natural	80.0%	80.5%	80.5%	80.0%	80.0%
Connections	Flue size - in. (round)	1 5	1 5	1 5	2 6	2 6
	Gas Piping Size	3/4	3/4	3/4	3/4	3/4
Fan Data	Air Volume - cfm	4400	4400	4400	4400	4400
	Number of Fans	2	2	2	2	2
	Diameter - in.	16	16	16	16	16
	Number of blades	4	4	4	4	5
	Number of Motors	2	2	2	2	2
	Motor Output - hp	1/8	1/8	1/8	1/8	1/8
	RPM	1075	1075	1075	1075	1075
Weight Data	Net Weight - lbs.	225	270	280	285	285
	Shipping Weight - lbs.	270	285	305	310	310

ELECTRICAL DATA

Line voltage data - 60hz	115 volts - 1 phase				
Motor amps	2.1 (4.2)	2.1 (4.2)	2.1 (4.2)	2.1 (4.2)	2.1 (4.2)
Total unit amps	9.0	9.0	9.0	9.0	9.0

OPTIONAL ACCESSORIES - MUST BE ORDERED EXTRA

Discharge	30° - 94K96	•	•	•	•	•
Nozzle	45° - 95K00	•	•	•	•	•
	60° - 16L30	•	•	•	•	•
	90° - 15L98	•	•	•	•	•
Hanging Bracket Kit	87277	•	•	•	•	•
LPG/Propane Kit	45L88	•	•	•	•	•
	63J57	•	•	•	•	•
	20L06	•	•	•	•	•

¹ 2-1/4 x 2-3/4 in. rectangular to 5 in. round adaptor is furnished with unit for flue connection.

² 2-1/4 x 2-3/4 in. rectangular to 6 in. round adaptor is furnished with unit for flue connection.

HORIZONTAL VENT KITS AND ELBOW

Unit Heater Model No.	Vent Diameter (in.)	Upslope Vent Kit	Catalog No.	Downslope Vent Kit	Catalog No.	45° Elbow	Catalog No.	90° Elbow	Catalog No.	¹ Minimum Vent Length (ft.)
LF24-100 LF24-115 LF24-145	4	C5VENT4KU	75W63	C5VENT4KD	75W67	C5VENT4E45 (Optional)	87W80	C5VENT4E (Optional)	75W71	5
LF24-175 LF24-200 LF24-230 LF24-250 LF24-300	5	C5VENT5KU	75W64	C5VENT5KD	75W68	C5VENT5E45 (Optional)	87W81	C5VENT5E (Required)	75W72	5
LF24-345 LF24-400	6	C5VENT6KU	75W65	C5VENT6KD	75W69	C5VENT6E45 (Optional)	87W82	C5VENT6E (Required)	75W73	5

¹ Length does not include termination (or elbow where applicable). NOTE - Elbow is required where shown to facilitate connection of horizontal vent kit to flue outlet.

STRAIGHT VENT PIPE - FOR HORIZONTAL VENTING

Unit Heater	Model No.	Vent Diameter (in.)	Length (in.)	Catalog No.
LF24-100	C5VENT4P6	4	6	75W77
LF24-115	C5VENT4P12	4	12	75W78
LF24-145	C5VENT4P36	4	36	75W79
LF24-175, LF24-200, LF24-230, LF24-250 LF24-300	C5VENT5P6	5	6	75W80
	C5VENT5P12	5	12	75W81
	C5VENT5P36	5	36	75W82
LF24-345 LF24-400	C5VENT6P12	6	12	75W83
	C5VENT6P36	6	36	75W84

HIGH ALTITUDE DERATE

Unit may be fired at full input up to 2000 feet above sea level. Above 2000 feet, manifold pressure must be adjusted on some units. Adjust pressure regulator to pressure shown in tables. If unit is installed at an altitude greater than 7500 ft. unit must be derated by 4 percent for each additional 1000 ft. above 7500 ft. In Canada, certification for installation at altitudes over 4500 feet above sea level is the jurisdiction of the local authorities.

NOTE – This is the only permissible derate for the units.

Model No.	Natural Gas Manifold Pressure - in. w.c.						
	0-2000 ft.	2001-2500 ft.	2501-3500 ft.	3501-4500 ft.	4501-5500 ft.	5501-6500 ft.	6501-7500 ft.
LF24-100 LF24-115 LF24-300	No adjustment	No adjustment	No adjustment	No adjustment	3.4	² 3.3	² 3.2
LF24-145	No adjustment	3.4	3.3	3.2	3.1	² 3.0	² 2.9
LF24-175 LF24-230	No adjustment	No adjustment	¹ No adjustment	¹ No adjustment	¹ No adjustment	^{1,2} No adjustment	^{1,2} No adjustment
LF24-200 LF24-250 LF24-345 LF24-400	No adjustment	No adjustment	No adjustment	3.4	3.3	3.2	3.1

¹ LF24-175 model - Combustion air inducer pressure switch must be replaced at altitudes over 2500 ft. Order **36W49** pressure switch.

² LF24-100 through -145 models - Combustion air inducer pressure switch must be replaced at altitudes over 5500 ft. Order **36W49** pressure switch.

Model No.	LPG/Propane Manifold Pressure - in. w.c.						
	0-2000 ft.	2001-2500 ft.	2501-3500 ft.	3501-4500 ft.	4501-5500 ft.	5501-6500 ft.	6501-7500 ft.
LF24-100 LF24-115 LF24-300	No adjustment	No adjustment	No adjustment	No adjustment	8.7	² 8.4	² 8.1
LF24-145	No adjustment	8.7	8.4	8.1	7.8	² 7.5	² 7.2
LF24-175 LF24-230	No adjustment	No adjustment	¹ No adjustment	¹ No adjustment	¹ No adjustment	^{1,2} No adjustment	^{1,2} No adjustment
LF24-200 LF24-250 LF24-345 LF24-400	No adjustment	No adjustment	No adjustment	9.2	8.9	8.6	8.3

¹ LF24-175 model - Combustion air inducer pressure switch must be replaced at altitudes over 2500 ft. Order **36W49** pressure switch.

² LF24-100 through -145 models - Combustion air inducer pressure switch must be replaced at altitudes over 5500 ft. Order **36W49** pressure switch.

THROW DATA

Model No.	Air Volume cfm	¹ Effective Throw feet
LF24-100, LF24-115, LF24-145	1900	60
LF24-175, LF24-200	2200	65
LF24-230, LF24-250, LF24-300, LF24-345, LF24-400	4400	80

NOTE - Adjustable horizontal louvers on unit allow a variation in throw and spread.

¹ Throw terminates where velocity reaches 50 ft. per minute.

INSTALLATION CLEARANCES

Top	6 inches
Sides	6 inches
Rear	18 inches
Bottom	0 inches
Flue	6 inches

NOTE - Provide adequate clearance for servicing.

See Installation Instructions for further installation considerations.

¹ RECOMMENDED MOUNTING HEIGHT

Model No.	Feet
LF24-100, LF24-115	16
LF24-145, LF24-175, LF24-200	20
LF24-230, LF24-250, LF24-300, LF24-345, LF24-400	30

¹ Recommended maximum mounting height from floor to bottom of unit. At heights greater than shown air throw distance and air temperature at floor level is affected.

MAXIMUM HORIZONTAL VENT LENGTHS

No. of Elbows	LF24-100 -115-145 -175-200	LF24-230 -250 -300	LF24-345	LF24-400
1	25	35	31	21
2	20	30	22	12
3	15	25	13	3
4	10	20	4	---
5	5	15	---	---
6	---	10	---	---
7	---	5	---	---

DIMENSIONS - INCHES (MM)

NOTE - Single fan model shown, LF24-100-115-145-175 and -200.
LF24-230-250-300-345 and -400 models have two fans.

¹ NOTE - Two rivetnuts are furnished on LF24-100-115 -145,-175 and -200 models.
- Four rivetnuts are furnished on LF24-230-250-300-345 and -400 models.

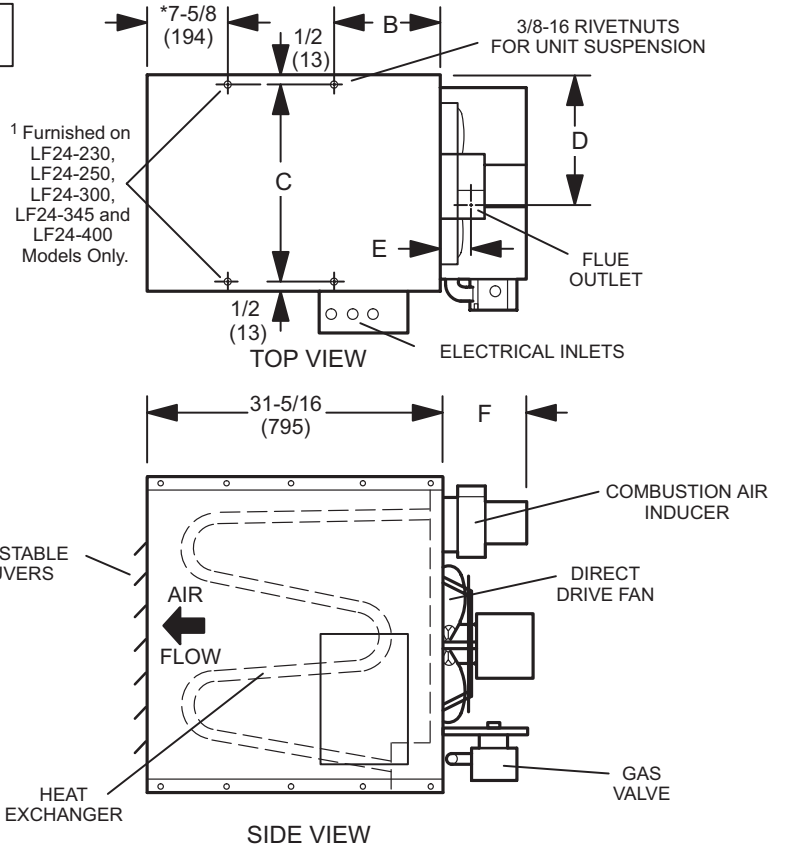

Model No.	A		B		C		D		E		F	
	in.	mm	in.	mm	in.	mm	in.	mm	in.	mm	in.	mm
LF24-100 LF24-115 LF24-145	20-3/16	512	11-1/2	292	19-1/16	484	11-3/4	298	3-1/4	83	7-7/8	200
LF24-175 LF24-200	23-1/8	588	11-1/2	292	22-1/16	560	8-1/2	337	3-1/4	83	8-11/16	220
LF24-230 LF24-250 LF24-300	41-1/8	1045	3-11/16	97	40	1016	17-3/4	451	3-1/2	89	8-11/16	220
LF24-345 LF24-400	41-1/8	1045	3-11/16	97	40	1016	17-1/2	445	3-1/2	89	9-13/16	248

ACCESSORY DIMENSIONS - INCHES (MM)

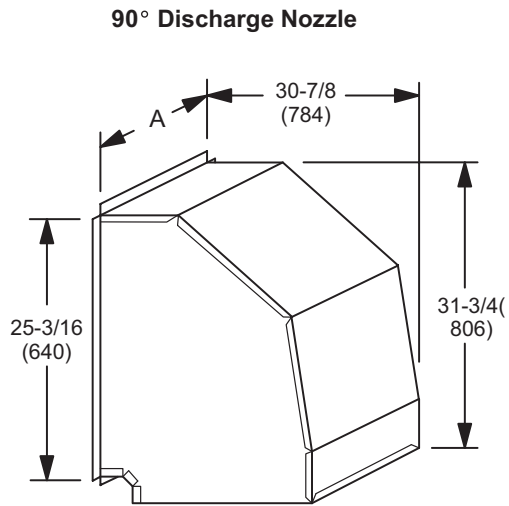
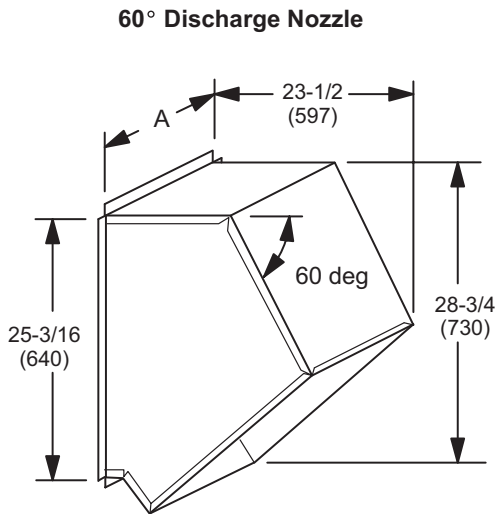
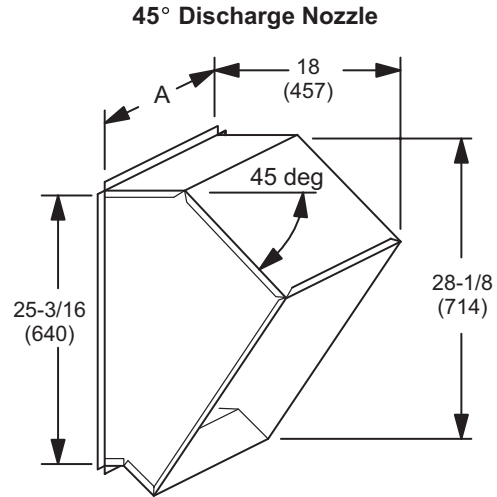
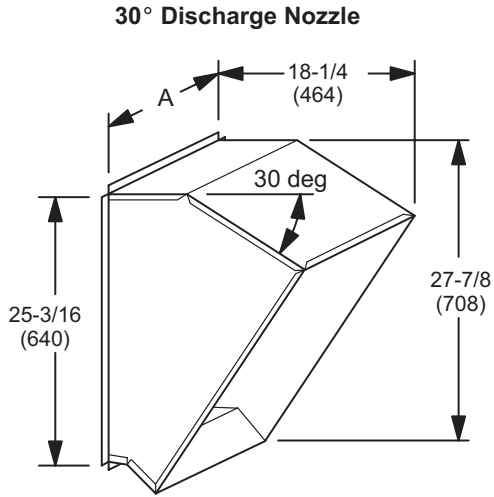

Model Usage	A	
	in.	mm
LF24-100 LF24-115	18-1/4	464
LF24-145 LF24-175 LF24-200	21-1/4	540
LF24-230 LF24-250 LF24-300 LF24-345 LF24-400	39-1/4	997

VENT KITS AND ACCESSORIES

HORIZONTAL VENT KITS (UPSLOPE)

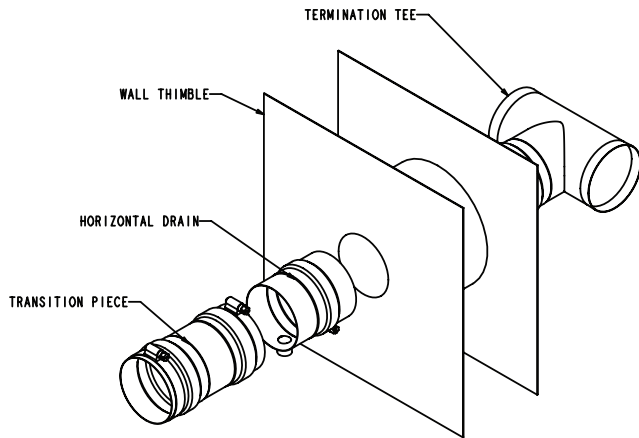

4 AND 6 INCH HORIZONTAL VENT KITS (DOWNSLOPE)

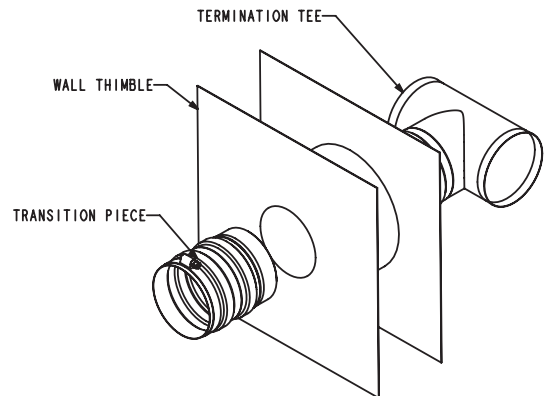

5 INCH HORIZONTAL VENT KIT (DOWNSLOPE)

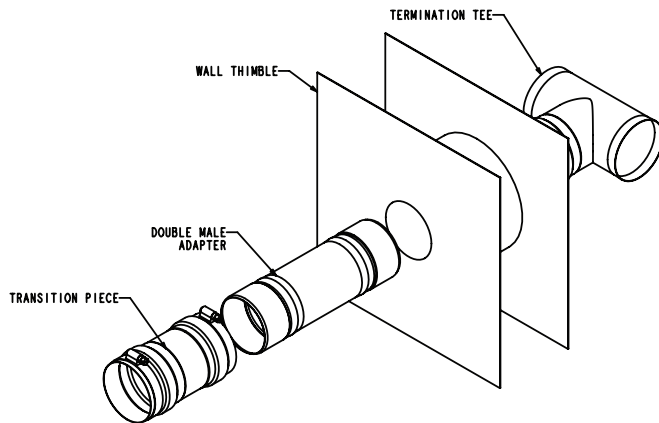

STRAIGHT PIPE (Typical)

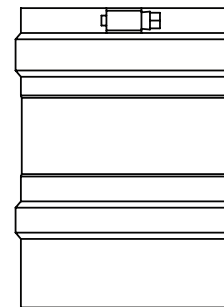

45° ELBOW (Typical)

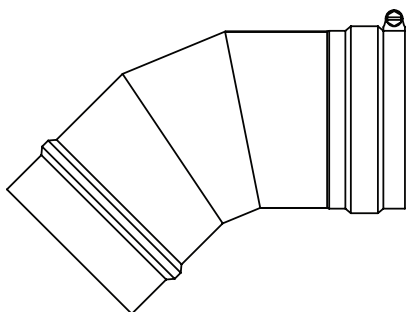

90° ELBOW (Typical)

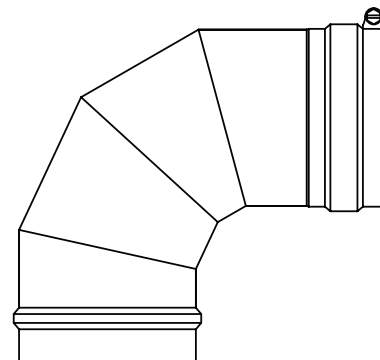

GUIDE SPECIFICATIONS

This specification specifies **[Lennox Industries LF24]** gas-fired unit heaters. Revise specification section number and title below to suit project requirements, specification practices and section content. Refer to CSI *MasterFormat* for other section numbers and titles.

This specification utilizes the Construction Specifications Institute (CSI) *Manual of Practice*, including *MasterFormat™*, *SectionFormat™* and *PageFormat™*. Optional text and text requiring a decision is indicated by **bold brackets[]** and proprietary information is indicated by **bold italic brackets[]**; delete text not required in final copy of specification. Specifier Notes typically precede specification text; delete notes in final copy of specification. Trade/brand names with appropriate symbols typically are used in Specifier Notes; symbols are not used in specification text. Metric conversion, where used, is soft metric conversion.

SECTION 23 55 33

FUEL-FIRED UNIT HEATERS

PART 1 GENERAL

1.1 SUMMARY

- A. Section Includes: Gas-Fired unit heaters

Specifier Note: Revise paragraph below to suit project requirements. Add section numbers and titles per CSI *MasterFormat* and specifier's practice.

- B. Related Sections:

Specifier Note: Article below may be omitted when specifying manufacturer's proprietary products and recommended installation. Retain Reference Article when specifying products and installation by an industry reference standard. If retained, list standard(s) referenced in this section. Indicate issuing authority name, acronym, standard designation and title. Establish policy for indicating edition date of standard referenced. Conditions of the Contract or Division 1 References Section may establish the edition date of standards. This article does not require compliance with standard, but is merely a listing of references used. Article below should list only those industry standards referenced in this section. Retain only those reference standards to be used within the text of this Section. Add and delete as required for specific project.

1.02 REFERENCES

- A. Certifications:
1. CSA International
 2. For use with natural or LPG/propane gas
 3. California Energy Commission (CEC)
- B. ISO 9001, units manufactured to quality standard

Specifier Note: Article below should be restricted to statements describing design or performance requirements and functional (not dimensional) tolerances of a complete system. Limit descriptions to composite and operational properties required to link components of a system together and to interface with other systems.

1.03 SYSTEM DESCRIPTION

- A. Electrical Requirements:
1. 60 Hz.
 2. 115 V
 3. Single phase
 4. 115V/24V or 120V/24V transformer
- B. Fuel Requirements: **[Natural gas]** [and]/[or] **[LPG/propane]**

Specifier Note: Article below includes submittal of relevant data to be furnished by Contractor before, during or after construction. Coordinate this article with Architect's and Contractor's duties and responsibilities in Conditions of the Contract and Division 1 Submittal Procedures Section.

1.04 SUBMITTALS

- A. General: Submit listed submittals in accordance with Conditions of the Contract and Division 1 Submittal Procedures.
- B. Product Data: Submit product data for specified products.
- C. Shop Drawings:
1. Submit shop drawings in accordance with Section **[01330 - Submittal Procedures]**.
 2. Indicate:
 - a. Equipment, piping and connections, together with valves, strainers, control assemblies, thermostatic controls, auxiliaries and hardware and recommended ancillaries which are mounted, wired and piped ready for final connection to building system, its size and recommended bypass connections.
 - b. Piping, valves and fittings shipped loose showing final location in assembly.
 - c. Control equipment shipped loose, showing final location in assembly.
 - d. Field wiring diagrams.
 - e. Dimensions, internal and external construction details, installation clearances, recommended method of installation, sizes and location of mounting bolt holes.
 - f. Detailed composite wiring diagrams for control systems showing factory installed wiring and equipment on packaged equipment or required for controlling devices or ancillaries, accessories, controllers.

GUIDE SPECIFICATIONS

- D. Quality Assurance:
 - 1. Test Reports: Certified test reports showing compliance with specified performance characteristics and physical properties.
 - 2. Certificates: Product certificates signed by manufacturer certifying materials comply with specified performance characteristics and criteria and physical requirements.
 - 3. Manufacturer's Instructions: Manufacturer's installation instructions.

Specifier Note: Coordinate paragraph below with Part 3 Field Quality Requirements Article herein. Retain or delete as applicable.

- E. Manufacturer's Field Reports: Manufacturer's field reports specified herein.
- F. Closeout Submittals: Submit the following:
 - 1. Warranty: Warranty documents specified herein.
 - 2. Operation and Maintenance Data: Operation and maintenance data for installed products in accordance with Division 1 Closeout Submittals (Maintenance Data and Operation Data) Section. Include methods for maintaining installed products and precautions against cleaning materials and methods detrimental to finishes and performance. Include names and addresses of spare part suppliers.
 - 3. Provide brief description of unit, with details of function, operation, control and component service.
 - 4. Commissioning Report: Submit commissioning reports, report forms and schematics in accordance with Section 01810 - Commissioning.

1.05 QUALITY ASSURANCE

- A. Qualifications:
 - 1. Installer experienced in performing work of this section who has specialized in installation of work similar to that required for this project.

1.06 DELIVERY, STORAGE & HANDLING

- A. General: Comply with Division 1 Product Requirements.
- B. Ordering: Comply with manufacturer's ordering instructions and lead-time requirements to avoid construction delays.
- C. Packing, Shipping, Handling and Delivery:
 - 1. Deliver materials in manufacturer's original, unopened, undamaged containers with identification labels intact.
 - 2. Ship, handle and unload units according to manufacturer's instructions.
- D. Storage and Protection:
 - 1. Store materials protected from exposure to harmful weather conditions.
 - 2. Factory shipping covers to remain in place until installation.

Specifier Note: Coordinate article below with Conditions of the Contract and Division 1 Closeout Submittals (Warranty).

1.07 WARRANTY

- A. Project Warranty: Refer to Conditions of the Contract for project warranty provisions.
- B. Manufacturer's Warranty: Submit, for Owner's acceptance, manufacturer's standard warranty document executed by authorized company official. Manufacturer's warranty is in addition to, and not a limitation of, other rights Owner may have under Contract Documents.

Specifier Note: Coordinate paragraph below with manufacturer's warranty requirements.

- C. Warranty: Commencing on Date of Installation.

Specifier Note: Refer to Lennox Equipment Limited Warranty certificate included with equipment for details.

- 1. Heat Exchanger:
 - a. Aluminized Steel: 10 years, limited (non-residential applications)
 - b. Stainless Steel: 15 years, limited (non-residential applications)
- 2. Solid-State Ignition Module: 1 year, limited (non-residential applications)
- 3. All other components: 1 year limited

PART 2 PRODUCTS

Specifier Note: Retain article below for proprietary method specification. Add product attributes, performance characteristics, material standards and descriptions as applicable. Use of such phrases as "or equal" or "or approved equal" or similar phrases may cause ambiguity in specifications. Such phrases require verification (procedural, legal and regulatory) and assignment of responsibility for determining "or equal" products.

2.01 [Lennox LF24] GAS-FIRED UNIT HEATERS

- A. Manufacturer: [Lennox Industries]
 - 1. Contact: [2100 Lake Park Blvd., Richardson, TX 75080; Telephone: (800) 453-6669; Web site: www.lennox.com]
- B. General:
 - 1. Air-Flow: Horizontal
 - 2. Venting
 - a. Horizontal
 - b. Vertical

GUIDE SPECIFICATIONS

3. All units to be shipped completely assembled at the factory
4. Hanging brackets to be supplied by manufacturer for field mounting of unit heater
5. Controls to be factory installed and wired
6. All units must pass a factory run-test before shipping
7. Installer to:
 - a. Make unit gas supply connections
 - b. Make electrical connections
 - c. Mount thermostat
 - d. Make flue connections

Specifier Note: LF24 models with BTUH requirements: 030 (30,000 Btuh), 045 (45,000 Btuh), 060 (60,000 Btuh), 075 (75,000 Btuh), 100 (100,000 Btuh), 115 (115,000 Btuh), 145 (145,000 Btuh), 175 (172,500 Btuh), 200 (195,000 Btuh), 230 (230,000 Btuh), 250 (250,000 Btuh), 300 (300,000 Btuh), 345 (345,000 Btuh), and 400 (390,000 Btuh).

8. See schedule for Btuh of unit required
- C. [Proprietary] Products/Systems: [LF24] Gas-fired unit heaters includes the following:**

1. Cabinet:
 - a. Pre-painted
 - b. Heavy gauge galvanized steel construction
 - c. Internally insulated cabinet
 - d. Adjustable louvers
 - e. Contains all electrical and safety controls

Specifier Note: Wiring Junction box located inside the cabinet on LF24 models 030, 045, 060 and 075. Wiring Junction box mounted on the exterior of the cabinet on LF24 models 100, 115, 145, 175, 200, 230, 250, 300, 345, and 400.

- f. Wiring Junction box mounted inside cabinet or on the exterior of the cabinet
2. Heating System:
 - a. Combination gas control valve
 1. 24 volt
 2. Manual shutoff valve
 3. Dual Valve:
 - a. Pressure regulator
 - b. Automatic electric valve
 - b. Solid-state igniter
 1. Direct-spark
 2. Intermittent spark
 - c. Electronic flame sensor
 - d. Combustion air inducer
 1. Pre-purge heat exchanger
 2. Pressure switch to prove operation
 3. Operates only during heating
 4. Blower motor is thermally protected
 - e. Heat Exchanger:
 1. Tubular

Specifier Note: Aluminized Steel heat exchanger is available on all LF24 models. Stainless Steel heat exchanger is only available on the LF24 models 100, 115, 145, 175, 200, 230, 250, 300, 345, and 400.

2. **[Aluminized Steel] [and][/][or] [Stainless steel]**
 3. Curving design
 4. Laboratory lifecycle tested
- f. Inshot burners:
 1. Aluminized steel
 2. Venturi to mix gas and air for proper combustion
 3. Assembly to be removable as a single component
 4. Individual burner removable from assembly
 - g. Limit Control:
 1. Factory installed
 2. Fixed temperature setting
 3. Protect heating system from abnormal operating conditions
3. Solid state control board
 - a. Fan timer control
 - b. Diagnostic LED for trouble shooting
 - c. Continuous fan operation
 4. Low voltage terminal strip

GUIDE SPECIFICATIONS

5. Supply fan:
 - a. Motor:
 1. Direct drive
 2. Permanently lubricated
 - b. Propeller type fan blade
6. [Optional Accessories]:
 - a. [Thermostat]

Specifier Note: Air Flow Nozzles are only available on the LF24 models 100, 115, 145, 175, 200, 230, 250, 300, 345, and 400.

- b. [Airflow Nozzles:]
 1. [30° from horizontal]
 2. [45° from horizontal]
 3. [60° from horizontal]
 4. [90° from horizontal]

Specifier Note: the High Altitude Pressure Switch Kit is only available on the LF24 models 100, 115, 145, and 175.

- c. [High Altitude Pressure Switch Kit]

2.02 PRODUCT SUBSTITUTIONS

- A. Substitutions: No substitutions permitted.

PART 3 EXECUTION

3.01 MANUFACTURER'S INSTRUCTIONS

Specifier Note: Article below is an addition to the CSI *SectionFormat*. Revise article below to suit project requirements and specifier's practice.

- A. Compliance: Comply with manufacturer's written data, including product technical bulletins, product catalog installation instructions and product carton installation instructions.

3.02 EXAMINATION

- A. Site Verification of Conditions: Verify substrate conditions, which have been previously installed under other sections, are acceptable for product installation in accordance with manufacturer's instructions.

3.03 INSTALLATION

- A. Install [**Lennox LF24**] gas fired unit heaters in accordance with manufacture's instructions and regulations of authorities having jurisdiction.

END OF SECTION

REVISIONS

Section	Description of Change
Features and Benefits	Updated Horizontal Vent Kits specs.
Horizontal Vent Kits and Elbow	Added new columns to the Horizontal Vent Kits and Elbow table for the optional 45° Elbow.
Vent Kits and Accessories	Replaced images.



Visit us at www.lennox.com

For the latest technical information, www.lennoxcommercial.com

Contact us at 1-800-4-LENNOX

NOTE - Due to Lennox' ongoing commitment to quality, Specifications, Ratings and Dimensions subject to change without notice and without incurring liability. Improper installation, adjustment, alteration, service or maintenance can cause property damage or personal injury. Installation and service must be performed by a qualified installer and servicing agency.

©2011 Lennox Industries, Inc.