

7½ - 12½ TON PACKAGED HEAT PUMP UP TO 11.5 EER & 3.4 COP

Cooling Capacity: 90,000 — 140,000 BTU/h

Heating Capacity: 90,000 — 142,000 BTU/h



■ Contents

Nomenclature	2
Product Specifications	4
Expanded Cooling Data	8
Expanded Heating Data	16
Airflow Data	18
Heat Kit Electrical Data	22
Dimensions	26
Wiring Diagrams	30
Accessories	36

■ Standard Features

- High-efficiency scroll compressors
- Two-stage cooling
- Copper tube / aluminum fin coils
- Power block for field wiring
- High-capacity, steel-cased filter drier
- Single-point entry
- 24-volt terminal strip
- Convertible airflow orientation
- Easy to service
- Built-in filter rack with standard 2" filters
- AHRI Certified; ETL Listed
- Units meet the performance outlined in Table 6.8.1B of ASHRAE Standard 90.1-2010

■ Cabinet Features

- Heavy-gauge, galvanized-steel cabinet with UV-resistant powder-paint finish
- Full perimeter rail
- Sloped drain pan



* Complete warranty details available from your local dealer or at www.daikincomfort.com.

		D	C	H	090	045	3	B	*	*	*	A	*
		1	2	3	4,5,6	7,8,9	10	11	12	13	14	15	16
													REVISION LEVELS
													Major & Minor
													FACTORY-INSTALLED OPTIONS
BRAND	D												
	Daikin												
CONFIGURATION	C												
	Standard Efficiency												
	T												
	High Efficiency (3-5 Tons)												
APPLICATION	C												
	Cooling												
	G												
	Gas Heat												
	H												
	Heat Pump												
NOMINAL COOLING CAPACITY													
036	3 Tons	102	8½ Tons	300	25 Tons								
048	4 Tons	120	10 Tons										
060	5 Tons	150	12½ tons										
072	6 Tons	180	15 Tons										
090	7½ Tons	240	20 Tons										
NOMINAL HEATING CAPACITY													
Gas/Electric	A/C H/P	Factory-Installed	Electric Heat										
045	45,000 BTU/h	XXX	No Heat										
090	90,000 BTU/h	010	10 kW	030	30 kW								
115	115,000 BTU/h	015	15 kW	031	30 kW								
140	140,000 BTU/h	016	15 kW	045	45 kW								
210	210,000 BTU/h	018	18 kW	046	45 kW								
350	350,000 BTU/h	020	20 kW	060	60 kW								
400	400,000 BTU/h	025	25 kW										
See product specifications for heat size(s) available for each capacity.													
VOLTAGE													
1	208-230/1/60	4	460/3/60										
3	208-230/3/60	7	575/3/60										
SUPPLY FAN/DRIVE TYPE/MOTOR													
B	Belt Drive (single speed)	V	Two-Speed Belt Drive (also designates 6-Ton with two-stage compressor)										
D	Direct Drive (3-5 Tons)												
FACTORY-INSTALLED OPTIONS													
X	No Options												
A	Ultra Low-Leak Downflow Economizer ¹												
H	Disconnect Switch (non-fused)												
J	Ultra Low-Leak Downflow Economizer ¹ ; Disconnect Switch (non-fused)												
V	Low-Leak Downflow Economizer ²												
W	Low-Leak Downflow Economizer ² ; Disconnect Switch (non-fused)												
Note: Not all options available for all products.													
¹ Please contact RRS Rooftop Systems directly if Power Exhaust is required.													
² Please use part number DPE901502 / DPE901504 / DPE901507 if Power Exhaust is required.													
													FACTORY-INSTALLED OPTIONS
X	Standard Aluminized Heat Exchanger												
S	Stainless-Steel Heat Exchanger												
D	Hinged Panels (3-12½ Tons)												
K	Stainless-Steel Heat Exchanger; Hinged panels (3-12½ Tons)												

FACTORY-INSTALLED OPTIONS

- **Stainless-Steel Heat Exchanger (DCG units only):** A tubular heat exchanger made of 409-type stainless steel is installed in the unit.
- **Low-Ambient Kit:** Allows for cooling operation at lower outdoor temperatures. On the 3- to 6-ton units, cooling operation is extended from 60°F ambient temperature to 35°F outside air temperature. On 7½ -20 ton units, cooling operation is extended from 35°F ambient temperature to 0°F outside air temperature. For 25 ton units, cooling operation is extended from 24°F ambient temperature to 0°F outside air temperature. **Economizers (Downflow):** Based on air conditions, can provide outside air to cool the space.
- **Electric Heat Kits (DCC and DCH units only):** Available in all voltage options.
- **Non-powered Convenience Outlet:** A 120V, 15A, GFCI outlet makes it easier for technicians to service the unit once an electrician runs power to the outlet.
- **Powered Convenience Outlet:** A 120V, 15A, GFCI outlet powered with a transformer built into the unit. When a factory-installed powered convenience outlet is installed in the equipment, the unit MCA (Min. Circuit Ampacity) will increase by 7.5A for 208/230V units, increase by 3.75A for 460V units, and by 3A for 575V units. The MOP (Max. Overcurrent Protection) device must be sized accordingly.
- **Disconnect Switch (non-fused; 3-phase units only):** A disconnect switch is installed in the unit and factory wiring will be complete from the switch to the unit. Please note that for air conditioning (DCC units) and heat pump models (DCH units), the appropriate electric heat kit must be ordered to be factory-installed along with the disconnect switch (non-fused) when it is ordered. Please note that for models with a powered convenience outlet option and a disconnect switch (non-fused) option, the power to the powered convenience outlet will be shut off when the disconnect switch (non-fused) is in the off position.
- **Return Air and/or Supply Air Smoke Detectors:** Return air and/or supply air smoke detectors are installed in the unit.
- **Hinged Access Panels:** Allows access to unit's major components. Combined with latches for easy access to control box, compressor, filters and blower motor. Available on 3-12½ Tons units.
- **Two-speed indoor fan blower models** are available on 6, 7½, 8½, 10, 12½, 15, 20 & 25 ton units. Section 6.4.3.10.b of ASHRAE Standard 90.1-2010 and Section 6.5.3.2.1.a of ASHRAE Standard 90.1-2013 require a minimum of two fan speeds. Section 140.4(m)1 of California Energy Commission Title 24 2013 contains a similar provision. When the units with the two-speed indoor fan blowers operate on a call for the first stage of cooling, the fan operates at low speed, which is 66% of full speed. When the units operate on a call for the second stage of cooling, the fan operates at full speed. In heating operation, the fan operates at full speed. During ventilation operation, the fan operates at low speed.

	DCH090 ***3B***A*	DCH090 ***3V***A*	DCH090 ***4B***A*	DCH090 ***4V***A*	DCH090 ***7B***A*	DCH090 ***7V***A*
Cooling Capacity						
Total BTU/h	90,000	90,000	90,000	90,000	90,000	90,000
Sensible BTU/h	65,700	65,700	65,700	65,700	65,700	65,700
EER / IEER	11.5 / 11.5	11.5 / 12.8	11.5 / 11.5	11.5 / 12.8	11.5 / 11.5	11.5 / 12.8
Decibels	83	83	83	83	83	83
AHRI Reference #s	7041909	7041912	7041909	7041912	7041909	7041912
Heating Capacity						
BTU/h / COP (47° F)	90,000 / 3.4	90,000 / 3.4	90,000 / 3.4	90,000 / 3.4	90,000 / 3.4	90,000 / 3.4
BTU/h / COP (17° F)	52,000 / 2.4	52,000 / 2.4	52,000 / 2.4	52,000 / 2.4	52,000 / 2.4	52,000 / 2.4
Evaporator Motor / Coil						
Motor Type	Belt Drive	2-speed Belt Drive	Belt Drive	2-speed Belt Drive	Belt Drive	2-speed Belt Drive
Indoor Nominal CFM	3,000	3,000	3,000	3,000	3,000	3,000
Indoor Motor FLA (Cooling)	7.8	6.0	3.9	2.9	2.3	2.4
Horsepower - RPM	2.0 - 1725	2.0/1740-1160	2.0 - 1725	2.0/1740-1160	2.0 - 1725	2.0/1745-1170
Piston Size (Cooling)	0.076	0.076	0.076	0.076	0.078	0.078
Filter Size	16" x 24" x 2"	16" x 24" x 2"	16" x 24" x 2"	16" x 24" x 2"	16" x 24" x 2"	16" x 24" x 2"
Drain Size (NPT)	¾"	¾"	¾"	¾"	¾"	¾"
R-410A Refrigerant Charge: Cir #1/ #2	220 oz.	220 oz.	220 oz.	220 oz.	200 oz.	200 oz.
Evaporator Coil Face Area (ft²)	10.2	10.2	10.2	10.2	10.2	10.2
Rows Deep / Fins per Inch	4 / 16	4 / 16	4 / 16	4 / 16	4 / 16	4 / 16
Belt Drive Evap Fan Data						
# of Wheels (D x W)	1 (15" x 12")	1 (15" x 12")	1 (15" x 12")	1 (15" x 12")	1 (15" x 12")	1 (15" x 12")
Motor Sheave / Blower Sheave	VL40 / AK74	VL40 / AK74	VL40 / AK74	VL40 / AK74	VL40 / AK74	VL40 / AK74
Belt	AX51	AX51	AX51	AX51	AX51	AX51
Condenser Fan / Coil						
Quantity of condenser Fan Motors	2	2	2	2	2	2
Horsepower - RPM	¼ - 1090	¼ - 1090	¼ - 890	¼ - 890	¼ - 1075	¼ - 1075
Fan Diameter / # Fan Blades	22 / 4	22 / 4	22 / 4	22 / 4	22 / 4	22 / 4
Outdoor Expansion Device	0.052	0.052	0.052	0.052	0.052	0.052
Outdoor Nominal CFM	7,600	7,600	7,600	7,600	7,600	7,600
Face Area (ft²)	32.4	32.4	32.4	32.4	32.4	32.4
# Coils / Rows Deep - Fins per Inch	2 / 2 - 20	2 / 2 - 20	2 / 2 - 20	2 / 2 - 20	2 / 2 - 20	2 / 2 - 20
Piston Size (Heating)	0.052	0.052	0.052	0.052	0.052	0.052
Compressor						
Quantity / Type / Stage	2 / Scroll / 1	2 / Scroll / 1	2 / Scroll / 1	2 / Scroll / 1	2 / Scroll / 1	2 / Scroll / 1
Compressor RLA / LRA	13.1 / 83.1	13.1 / 83.1	6.1 / 41.0	6.1 / 41.0	4.4 / 33.0	4.4 / 33.0
Electrical Data						
Voltage / Phase / Frequency	208-230 / 3 / 60	208-230 / 3 / 60	460 / 3 / 60	460 / 3 / 60	575 / 3 / 60	575 / 3 / 60
Indoor Blower HP / FLA	2.0/7.8	2/6.0	2.0/3.9	2/2.9	2.0/2.3	2/2.4
Max External Static	1.0"	1.0"	1.0"	1.0"	1.0"	1.0"
Outdoor Fan HP / FLA	¼ / 1.4	¼ / 1.4	¼ / 0.7	¼ / 0.7	¼ / 0.55	¼ / 0.55
Total Unit Amps	36.8	35.0	17.5	16.5	12.2	12.3
Min. Circuit Ampacity ¹	40.1	38.3	19	18	13.3	13.4
Max. Overcurrent Protection (amps) ²	50	50	25	20	15	15
Entrance Power Supply	Locating Dimple	Locating Dimple	Locating Dimple	Locating Dimple	Locating Dimple	Locating Dimple
Entrance Control Voltage						
Operating Weight (lbs)	1135	1135	1135	1135	1135	1135
Ship Weight (lbs)	1175	1175	1175	1175	1175	1175

¹ Wire size should be determined in accordance with National Electrical Codes. Extensive wire runs will require larger wire sizes.

² May use fuses or HACR-type circuit breakers of the same size as noted.

NOTE: Always check the S&R plate for electrical data on the unit being installed.

	DCH102 ***3B***A*	DCH102 ***3V***A*	DCH102 ***4B***A*	DCH102 ***4V***A*	DCH102 ***7B***A*	DCH102 ***7V***A*
COOLING CAPACITY						
Total, BTU/h	102,000	102,000	102,000	102,000	102,000	102,000
Sensible BTU/h	73,440	73,440	73,440	73,440	73,440	73,440
EER / IEER	11.1 / 11.2	11.1 / 13.0	11.1 / 11.2	11.1 / 13.0	11.1 / 11.2	11.1 / 13.0
Decibels	83	83	83	83	83	83
ARI Reference #s	7370922	7370925	7370922	7370925	7370922	7370925
HEATING CAPACITY						
BTU/h (47°F)	102,000	102,000	102,000	102,000	102,000	102,000
COP (47°F)	3.4	3.4	3.4	3.4	3.4	3.4
BTU/h (17°F)	55,500	55,500	55,500	55,500	55,500	55,500
COP (17°F)	2.25	2.25	2.25	2.25	2.25	2.25
EVAPORATOR MOTOR / COIL						
Motor Type	Belt Drive	2-speed Belt Drive	Belt Drive	2-speed Belt Drive	Belt Drive	2-speed Belt Drive
Indoor Nominal CFM	3,400	3,400	3,400	3,400	3,400	3,400
Indoor Motor FLA (Cooling)	7.8	6.0	3.9	2.9	2.3	2.4
Horsepower - RPM	2 / 1725	2.0/1740-1160	2 / 1725	2.0/1740-1160	2 / 1725	2.0/1745-1170
Piston Size (Cooling)	0.08	0.08	0.08	0.08	0.08	0.08
Filter Size (in.) (Qty)	(4) 16 x 24 x 2	(4) 16 x 24 x 2	(4) 16 x 24 x 2	(4) 16 x 24 x 2	(4) 16 x 24 x 2	(4) 16 x 24 x 2
Drain Size (NPT)	3/4"	3/4"	3/4"	3/4"	3/4"	3/4"
R-410A Refrigerant Charge Cir #1 & #2 (oz.)	205 / 205	235/225	205 / 205	235/225	205 / 205	235/225
Evaporator Coil Face Area (ft ²)	10.2	10.2	10.2	10.2	10.2	10.2
Rows Deep / Fins per Inch	4 / 14	4 / 14	4 / 14	4 / 14	4 / 14	4 / 14
BELT DRIVE EVAP FAN DATA						
# of Wheels (D x W)	1 (15" x 12")	1 (15" x 12")	1 (15" x 12")	1 (15" x 12")	1 (15" x 12")	1 (15" x 12")
Motor Sheave / Blower Sheave	VL40 / AK74	VL40 / AK74	VL40 / AK74	VL40 / AK74	VL40 / AK74	VL40 / AK74
Belt	AX51	AX51	AX51	AX51	AX51	AX51
CONDENSER FAN / COIL						
Quantity of Condenser Fan Motors	2	2	2	2	2	2
Horsepower - RPM	1/4" - 1,090	1/4" - 1,090	1/4" - 890	1/4" - 890	1/4" - 1,075	1/4" - 1,075
Fan Diameter / # Fan Blades	22 / 4	22 / 4	22 / 4	22 / 4	22 / 4	22 / 4
Outdoor Nominal CFM	7,600	7,600	7,600	7,600	7,600	7,600
Face Area (ft ²)	32.4	32.4	32.4	32.4	32.4	32.4
Rows Deep / Fins per Inch	2 / 22	2 / 22	2 / 22	2 / 22	2 / 22	2 / 22
Piston Size (Heating)	0.059	0.059	0.059	0.059	0.059	0.059
COMPRESSOR						
Quantity / Type	2 / Scroll / 1	2 / Scroll / 1	2 / Scroll / 1	2 / Scroll / 1	2 / Scroll / 1	2 / Scroll / 1
Stage	14.5 / 98	14.5 / 98	6.3 / 55	6.3 / 55	6.0 / 41	6.0 / 41
Compressor RLA / LRA ea.						
ELECTRICAL DATA / STATIC						
Voltage / Phase / 60 Hz	208-230 / 3	208-230 / 3	460 / 3	460 / 3	575 / 3	575 / 3
Outdoor Fan FLA ea.	1"	1"	1	1	1	1
Total Unit Amps	1.4	1.4	0.7	0.7	0.55	0.55
Min. Circuit Ampacity ¹	39.6	37.8	18.1	16.9	15.5	15.6
Max. Overcurrent Protection (amps) ²	43.2	41.4	19.7	18.5	17	17
Entrance Power Supply & Control Voltage	50	50	25	20	20	20
	Locating Dimple	Locating Dimple	Locating Dimple	Locating Dimple	Locating Dimple	Locating Dimple
OPERATING WEIGHT (LBS)	1285	1285	1285	1285	1285	1285
SHIP WEIGHT (LBS)	1310	1310	1310	1310	1310	1310

¹ Wire size should be determined in accordance with National Electrical Codes. Extensive wire runs will require larger wire sizes.

² May use fuses or HACR-type circuit breakers of the same size as noted.

NOTE: Always check the S&R plate for electrical data on the unit being installed.

	DCH120 ***3B***A*	DCH120 ***3V***A*	DCH120 ***4B***A*	DCH120 ***4V***A*	DCH120 ***7B***A*	DCH120 ***7V***A*
COOLING CAPACITY						
Total BTU/h	115,000	113,000	115,000	113,000	115,000	113,000
Sensible BTU/h	84,700	84,700	84,700	84,700	84,700	84,700
EER / IEER	11.1 / 11.5	11.1 / 12.6	11.1 / 11.5	11.1 / 12.6	11.1 / 11.5	11.1 / 12.6
Decibels	83	83	83	83	83	83
ARI Reference #s	6345705	6345706	6345705	6345706	6345705	6345706
HEATING CAPACITY						
BTU/h (47° F)	116,000	116,000	116,000	116,000	116,000	116,000
COP (47°F)	3.4	3.4	3.4	3.4	3.4	3.4
BTU/h (17° F)	56,000	56,000	56,000	56,000	56,000	56,000
COP (17°F)	2.4	2.4	2.4	2.4	2.4	2.4
EVAPORATOR MOTOR / COIL						
Motor Type	Belt Drive	2-speed Belt Drive	Belt Drive	2-speed Belt Drive	Belt Drive	2-speed Belt Drive
Indoor Nominal CFM	3,500	3,500	3,500	3,500	3,500	3,500
Indoor motor FLA (Cooling)	7.8	6.4	3.9	3.0	2.5	2.4
Horsepower - RPM	2.0/1725	2.0/1750-1165	2.0/1725	2.0/1750-1165	2.0/1725	2.0/1750-1165
Piston Size (Cooling)	0.086	0.086	0.086	0.086	0.086	0.086
Expansion Device	Orifice	Orifice	Orifice	Orifice	Orifice	Orifice
Filter Size (in.) (Qty = 4)	16 x 24 x 2	16 x 24 x 2	16 x 24 x 2	16 x 24 x 2	16 x 24 x 2	16 x 24 x 2
Drain Size (NPT)	¾"	¾"	¾"	¾"	¾"	¾"
R-410A Refrigerant Charge Cir #1 & #2 (oz.)	225 / 225	225 / 225	225 / 225	225 / 225	225 / 225	225 / 225
Evaporator Coil Face Area (ft²)	10.2	10.2	10.2	10.2	10.2	10.2
Rows Deep/ Fins per Inch	4 / 14	4 / 14	4 / 14	4 / 14	4 / 14	4 / 14
BELT DRIVE EVAP FAN DATA						
# of Wheels (D x W)	(1) 15" x 15"	(1) 15" x 15"	(1) 15" x 15"	(1) 15" x 15"	(1) 15" x 15"	(1) 15" x 15"
Motor Sheave / Blower Sheave	VL40 / AK74	VL40 / AK74	VL40 / AK74	VL40 / AK74	VL40 / AK74	VL40 / AK74
Belt	AX51	AX50	AX51	AX50	AX51	AX50
CONDENSER FAN / COIL						
Quantity of Condenser Fan Motors	2	2	2	2	2	2
Horsepower - RPM	½ - 1,075	½ - 1,075	½ - 1,075	½ - 1,075	½ - 1,125	½ - 1,125
Fan Diameter / # Fan Blades	22 / 3	22 / 3	22 / 3	22 / 3	22 / 3	22 / 3
Outdoor Nominal CFM	8,200	8,200	8,200	8,200	8,200	8,200
Face Area (ft²)	32.4	32.4	32.4	32.4	32.4	32.4
# Coils / Rows Deep - Fins per Inch	2 / 2 - 22	2 / 2 - 22	2 / 2 - 22	2 / 2 - 22	2 / 2 - 22	2 / 2 - 22
Piston Size (Heating)	0.064	0.064	0.064	0.064	0.064	0.064
COMPRESSOR						
Quantity / Type / Stage	2 / Scroll / 1	2 / Scroll / 1	2 / Scroll / 1	2 / Scroll / 1	2 / Scroll / 1	2 / Scroll / 1
Compressor RLA / LRA ea.	16 / 110.0	16 / 110.0	7.8 / 52.0	7.8 / 52.0	5.7 / 38.9	5.7 / 38.9
ELECTRICAL DATA						
Voltage/Phase/ Frequency	208-230/3/60	208-230/3/60	460/3/60	460/3/60	575/3/60	575/3/60
Outdoor Fan RLA ea.	2.00	2.00	0.85	0.85	0.67	0.67
Total Unit Amps	45	43	22	21	16	16
Min. Circuit Ampacity ¹	49	47	24	23	17	17
Max. Overcurrent Protection (amps) ²	60	60	30	30	20	20
Entrance Power Supply & Control Voltage	Locating Dimple	Locating Dimple	Locating Dimple	Locating Dimple	Locating Dimple	Locating Dimple
OPERATING WEIGHT (LBS)						
	1285	1285	1285	1285	1285	1285
SHIP WEIGHT (LBS)						
	1310	1310	1310	1310	1310	1310

¹ Wire size should be determined in accordance with National Electrical Codes. Extensive wire runs will require larger wire sizes.

² May use fuses or HACR-type circuit breakers of the same size as noted.

NOTE: Always check the S&R plate for electrical data on the unit being installed.

	DCH150 ***3B***A*	DCH150 ***3V***A*	DCH150 ***4B***A*	DCH150 ***4V***A*	DCH150 ***7B***A*	DCH150 ***7V***A*
COOLING CAPACITY						
Total, BTU/h	140,000	140,000	140,000	140,000	140,000	140,000
Sensible BTU/h	98,000	98,000	98,000	98,000	98,000	98,000
EER / IEER	10.6 / 10.7	10.6 / 11.8	10.6 / 10.7	10.6 / 11.8	10.6 / 10.7	10.6 / 11.8
Decibels	83	83	83	83	83	83
ARI Reference #s	6885863	6885866	6885863	6885866	6885863	6885866
HEATING CAPACITY						
BTU/hr (47°F)	142,000	142,000	142,000	142,000	142,000	142,000
COP (47°F)	3.2	3.2	3.2	3.2	3.2	3.2
BTU/hr (17°F)	82,000	82,000	82,000	82,000	82,000	82,000
COP (17°F)	2.1	2.1	2.1	2.1	2.1	2.1
EVAPORATOR MOTOR / COIL						
Motor Type	Belt Drive	2-speed Belt Drive	Belt Drive	2-speed Belt Drive	Belt Drive	2-speed Belt Drive
Indoor Nominal CFM	4,000	4,000	4,000	4,000	4,000	4,000
Indoor Motor FLA (Cooling)	9.4	9.1	4.7	4.3	4.2	3.5
Horsepower - RPM	3.0 - 1,725	3.0/1760-1165	3.0 - 1,725	3.0/1760-1165	3.0 - 1,725	3.0/1760-1165
Piston Size (Cooling)	0.094	0.094	0.094	0.094	0.094	0.094
Filter Size (in.) (Qty)	(4) 20 x 25 x 2	(4) 20 x 25 x 2	(4) 20 x 25 x 2	(4) 20 x 25 x 2	(4) 20 x 25 x 2	(4) 20 x 25 x 2
Drain Size (NPT)	¾"	¾"	¾"	¾"	¾"	¾"
R-410A Refrigerant Charge Cir #1 & #2 (oz.)	301 / 301	301 / 301	301 / 301	301 / 301	301 / 301	301 / 301
Evaporator Coil Face Area (ft²)	14.7	14.7	14.7	14.7	14.7	14.7
Rows Deep / Fins per Inch	4 / 15	4 / 15	4 / 15	4 / 15	4 / 15	4 / 15
BELT DRIVE EVAP FAN DATA						
# of Wheels (D x W)	(1) 15" x 15"	(1) 15" x 15"	(1) 15" x 15"	(1) 15" x 15"	(1) 15" x 15"	(1) 15" x 15"
Motor Sheave / Blower Sheave	VL40 / AK66	VP44 / AK71	VL40 / AK66	VP44 / AK71	VL40 / AK66	VP44 / AK71
Belt	AX49	AX48	AX49	AX48	AX49	AX48
CONDENSER FAN / COIL						
Quantity of condenser Fan Motors	2.0	2.0	2.0	2.0	2.0	2.0
Horsepower - RPM	½ - 1,075	½ - 1,075	½ - 1,075	½ - 1,075	½ - 1,075	½ - 1,075
Fan Diameter / # Fan Blades	22/ 3	22/ 3	22/ 3	22/ 3	22/ 3	22/ 3
Outdoor Nominal CFM	8,200	8,200	8,200	8,200	8,200	8,200
Face Area (ft²)	35.3	35.3	35.3	35.3	35.3	35.3
# Coils / Rows Deep - Fins per Inch	2/3- 15	2/3- 15	2/3- 15	2/3- 15	2/3- 15	2/3- 15
Piston Size (Heating)	0.07	0.07	0.07	0.07	0.07	0.07
COMPRESSOR						
Quantity / Type/ Stage	2 / Scroll / 1	2 / Scroll / 1	2 / Scroll / 1	2 / Scroll / 1	2 / Scroll / 1	2 / Scroll / 1
Compressor RLA / LRA ea.	22.4 / 149	22.4 / 149	10.6 / 75	10.6 / 75	7.7 / 54	7.7 / 54
ELECTRICAL DATA / STATIC						
Voltage / Phase / Frequency	208-230/ 3/ 60	208-230/ 3/ 60	460/ 3/ 60	460/ 3/ 60	575/ 3/ 60	575/ 3/ 60
Standard Max Static	1.4"	1.4"	1.4"	1.4"	1.4"	1.4"
Outdoor Fan FLA ea.	2.00	2.00	0.85	0.85	0.67	0.67
Total Unit Amps	59	57.9	28	26.9	21.4	20.7
Min. Circuit Ampacity ¹	65	63.5	31	29.9	23	23
Max. Overcurrent Protection (amps) ²	80	80	40	40	30	30
Entrance Power Supply	Locating	Locating	Locating	Locating	Locating	Locating
Entrance Control Voltage	Dimple	Dimple	Dimple	Dimple	Dimple	Dimple
OPERATING WEIGHT (LBS)	1325	1325	1325	1325	1325	1325
SHIP WEIGHT (LBS)	1350	1350	1350	1350	1350	1350

¹ Wire size should be determined in accordance with National Electrical Codes. Extensive wire runs will require larger wire sizes.

² May use fuses or HACR-type circuit breakers of the same size as noted.

NOTE: Always check the S&R plate for electrical data on the unit being installed.

IDB		OUTDOOR AMBIENT TEMPERATURE																																															
		65								75								85								95								105								115							
		AIRFLOW						ENTERING INDOOR WET BULB TEMPERATURE						75						85						95						105						115											
59	63	67	71	59	63	67	71	59	63	67	71	59	63	67	71	59	63	67	71	59	63	67	71	59	63	67	71	59	63	67	71	59	63	67	71	59	63	67	71										
70	MBh	88.2	91.4	100.2	-	86.1	89.3	97.8	-	84.1	87.2	95.5	-	82.0	85.0	93.2	-	77.9	80.8	88.5	-	77.9	80.8	88.5	-	72.2	74.8	82.0	-	72.2	74.8	82.0	-																
	S/T	0.73	0.61	0.42	-	0.76	0.63	0.44	-	0.78	0.65	0.45	-	0.80	0.67	0.47	-	0.83	0.70	0.48	-	0.83	0.70	0.48	-	0.84	0.70	0.49	-	0.84	0.70	0.49	-																
	ΔT	18	15	12	-	18	15	12	-	18	15	12	-	18	16	12	-	18	15	12	-	18	15	12	-	17	14	11	-	17	14	11	-																
	kW	6.19	6.32	6.50	-	6.64	6.77	6.98	-	7.03	7.17	7.39	-	7.37	7.53	7.76	-	7.67	7.83	8.08	-	7.67	7.83	8.08	-	7.92	8.09	8.35	-	7.92	8.09	8.35	-																
	Hi PR	234	252	266	-	262	282	298	-	298	321	339	-	340	366	386	-	382	411	434	-	382	411	434	-	422	454	480	-	422	454	480	-																
Lo PR	108	115	126	-	114	122	133	-	119	126	138	-	125	133	145	-	131	139	152	-	131	139	152	-	135	144	157	-	135	144	157	-																	
70	MBh	85.6	88.7	97.2	-	83.6	86.7	95.0	-	81.6	84.6	92.7	-	79.7	82.6	90.5	-	75.7	78.4	85.9	-	75.7	78.4	85.9	-	70.1	72.6	79.6	-	70.1	72.6	79.6	-																
	S/T	0.70	0.58	0.40	-	0.72	0.61	0.42	-	0.74	0.62	0.43	-	0.77	0.64	0.44	-	0.80	0.66	0.46	-	0.80	0.66	0.46	-	0.80	0.67	0.46	-	0.80	0.67	0.46	-																
	ΔT	18	16	12	-	19	16	12	-	19	16	12	-	19	16	12	-	18	16	12	-	18	16	12	-	17	15	11	-	17	15	11	-																
	kW	6.15	6.27	6.45	-	6.59	6.72	6.92	-	6.98	7.12	7.34	-	7.32	7.47	7.70	-	7.61	7.77	8.01	-	7.61	7.77	8.01	-	7.86	8.03	8.28	-	7.86	8.03	8.28	-																
	Hi PR	231	249	263	-	260	279	295	-	295	318	336	-	336	362	382	-	378	407	430	-	378	407	430	-	418	450	475	-	418	450	475	-																
Lo PR	107	114	124	-	113	120	132	-	118	125	137	-	124	132	144	-	130	138	150	-	130	138	150	-	134	143	156	-	134	143	156	-																	
70	MBh	79.0	81.9	89.7	-	77.2	80.0	87.7	-	75.4	78.1	85.6	-	73.5	76.2	83.5	-	69.8	72.4	79.3	-	69.8	72.4	79.3	-	64.7	67.1	73.5	-	64.7	67.1	73.5	-																
	S/T	0.67	0.56	0.39	-	0.70	0.58	0.40	-	0.72	0.60	0.41	-	0.74	0.62	0.43	-	0.77	0.64	0.44	-	0.77	0.64	0.44	-	0.77	0.65	0.45	-	0.77	0.65	0.45	-																
	ΔT	20	18	13	-	21	18	14	-	21	18	14	-	21	18	14	-	21	18	13	-	21	18	13	-	19	17	13	-	19	17	13	-																
	kW	6.01	6.13	6.31	-	6.44	6.57	6.76	-	6.81	6.95	7.16	-	7.15	7.29	7.52	-	7.43	7.58	7.82	-	7.43	7.58	7.82	-	7.67	7.83	8.08	-	7.67	7.83	8.08	-																
	Hi PR	224	242	255	-	252	271	286	-	286	308	326	-	326	351	371	-	367	395	417	-	367	395	417	-	406	436	461	-	406	436	461	-																
Lo PR	104	111	121	-	110	117	128	-	114	121	133	-	120	128	139	-	126	134	146	-	126	134	146	-	130	138	151	-	130	138	151	-																	
75	MBh	89.7	92.3	100.0	107.3	87.6	90.2	97.6	104.8	85.5	88.0	95.3	102.3	83.4	85.9	93.0	99.8	79.3	81.6	88.3	94.8	79.3	81.6	88.3	94.8	73.4	75.6	81.8	87.8	73.4	75.6	81.8	87.8																
	S/T	0.83	0.75	0.56	0.36	0.86	0.77	0.58	0.38	0.89	0.79	0.60	0.39	0.91	0.82	0.62	0.40	0.95	0.85	0.64	0.41	0.95	0.85	0.64	0.41	0.96	0.86	0.65	0.42	0.96	0.86	0.65	0.42																
	ΔT	20	19	15	11	21	19	16	11	21	19	16	11	21	19	16	11	21	19	15	11	21	19	15	11	19	18	14	10	19	18	14	10																
	kW	6.24	6.36	6.55	6.75	6.69	6.82	7.03	7.25	7.08	7.23	7.45	7.69	7.43	7.59	7.83	8.07	7.73	7.89	8.14	8.40	7.73	7.89	8.14	8.40	7.99	8.16	8.42	8.69	7.99	8.16	8.42	8.69																
	Hi PR	236	254	268	280	265	285	301	314	301	324	342	357	343	369	390	407	386	415	439	458	386	415	439	458	427	459	485	506	427	459	485	506																
Lo PR	109	116	127	135	116	123	134	143	120	128	139	149	126	134	146	156	132	141	154	163	132	141	154	163	137	145	159	169	137	145	159	169																	
75	MBh	87.1	89.7	97.0	104.1	85.1	87.6	94.8	101.7	83.0	85.5	92.5	99.3	81.0	83.4	90.3	96.9	77.0	79.2	85.8	92.0	77.0	79.2	85.8	92.0	71.3	73.4	79.4	85.3	71.3	73.4	79.4	85.3																
	S/T	0.79	0.71	0.54	0.35	0.82	0.74	0.56	0.36	0.84	0.76	0.57	0.37	0.87	0.78	0.59	0.38	0.90	0.81	0.61	0.39	0.90	0.81	0.61	0.39	0.91	0.82	0.62	0.40	0.91	0.82	0.62	0.40																
	ΔT	21	20	16	11	21	20	16	11	21	20	16	11	22	20	16	11	22	20	16	11	21	20	16	11	20	18	15	10	20	18	15	10																
	kW	6.19	6.32	6.50	6.70	6.64	6.77	6.98	7.19	7.03	7.17	7.39	7.63	7.38	7.53	7.76	8.01	7.67	7.83	8.08	8.34	7.67	7.83	8.08	8.34	7.92	8.09	8.35	8.62	7.92	8.09	8.35	8.62																
	Hi PR	234	252	266	277	262	282	298	311	298	321	339	354	340	366	386	403	382	411	434	453	382	411	434	453	422	454	480	501	422	454	480	501																
Lo PR	108	115	126	134	114	122	133	141	119	126	138	147	125	133	145	154	131	139	152	162	131	139	152	162	135	144	157	167	135	144	157	167																	
75	MBh	80.4	82.7	89.6	96.1	78.5	80.8	87.5	93.9	76.6	78.9	85.4	91.7	74.8	77.0	83.3	89.4	71.0	73.1	79.2	85.0	71.0	73.1	79.2	85.0	65.8	67.7	73.3	78.7	65.8	67.7	73.3	78.7																
	S/T	0.77	0.69	0.52	0.33	0.79	0.71	0.54	0.35	0.81	0.73	0.55	0.35	0.84	0.75	0.57	0.37	0.87	0.78	0.59	0.38	0.87	0.78	0.59	0.38	0.88	0.79	0.60	0.38	0.88	0.79	0.60	0.38																
	ΔT	24	22	18	12	24	22	18	12	24	22	18	12	24	22	18	13	24	22	18	12	24	22	18	12	22	20	17	12	22	20	17	12																
	kW	6.06	6.18	6.36	6.55	6.49	6.62	6.82	7.02	6.87	7.01	7.22	7.45	7.20	7.35	7.58	7.82	7.49	7.65	7.88	8.13	7.49	7.65	7.88	8.13	7.73	7.90	8.15	8.41	7.73	7.90	8.15	8.41																
	Hi PR	227	244	258	269	254	274	289	302	289	311	329	343	330	355	375	391	371	399	421	439	371	399	421	439	410	441	466	486	410	441	466	486																
Lo PR	105	112	122	130	111	118	129	137	115	123	134	143	121	129	141	150	127	135	147	157	127	135	147	157	131	140	153	162	131	140	153	162																	

IDB: Entering Indoor Dry Bulb Temperature
 High and low pressures are measured at the liquid and suction access fittings.
 Design Superheat 7±2 °F, Design Subcooling 12 ±2 °F pressures measured @ the suction and liquid service ports, AHR1 95 test conditions
 Shaded area reflects ACCA (TVA) Rating Conditions

IDB		OUTDOOR AMBIENT TEMPERATURE																																											
		65					75					85					95					105					115																		
		ENTERING INDOOR WET BULB TEMPERATURE																																											
AIRFLOW	59	63	67	71	75	79	83	87	91	95	99	103	107	111	115	59	63	67	71	75	79	83	87	91	95	99	103	107	111	115	59	63	67	71	75	79	83	87	91	95	99	103	107	111	115
80	MBh	91.3	93.3	99.7	106.5	89.2	91.1	97.3	104.1	87.0	88.9	95.0	101.6	84.9	86.8	92.7	99.1	80.7	82.4	88.1	94.1	80.7	82.4	88.1	94.1	80.7	82.4	88.1	94.1	74.7	76.4	81.6	87.2												
	S/T	0.91	0.86	0.70	0.52	0.95	0.89	0.72	0.54	1.00	0.91	0.74	0.55	1.00	0.94	0.77	0.57	1.00	1.00	0.79	0.59	1.00	1.00	0.79	0.59	1.00	1.00	0.79	0.59	1.00	1.00	0.80	0.60												
	ΔT	23	22	19	15	23	22	19	15	24	22	19	15	23	22	19	15	22	22	19	15	22	22	19	15	20	21	18	14	20	21	18	14												
	kW	6.29	6.41	6.60	6.80	6.74	6.88	7.08	7.30	7.14	7.29	7.51	7.75	7.49	7.65	7.89	8.14	7.79	7.96	8.21	8.47	7.79	7.96	8.21	8.47	8.05	8.22	8.48	8.76	8.05	8.22	8.48	8.76												
	Hi PR	238	257	271	283	268	288	304	317	304	328	346	361	347	373	394	411	390	420	443	462	390	420	443	462	431	464	490	511	431	464	490	511												
Lo PR	110	118	128	137	117	124	136	144	121	129	141	150	127	136	148	158	134	142	155	165	134	142	155	165	138	147	160	171	138	147	160	171													
3000	MBh	88.6	90.6	96.8	103.4	86.6	88.5	94.5	101.0	84.5	86.3	92.3	98.6	82.4	84.2	90.0	96.2	78.3	80.0	85.5	91.4	78.3	80.0	85.5	91.4	72.5	74.1	79.2	84.7	72.5	74.1	79.2	84.7												
	S/T	0.87	0.82	0.67	0.50	0.90	0.85	0.69	0.52	0.93	0.87	0.71	0.53	0.96	0.90	0.73	0.55	0.99	0.93	0.76	0.57	0.99	0.93	0.76	0.57	1.00	0.94	0.76	0.57	1.00	0.94	0.76	0.57												
	ΔT	24	23	20	16	24	23	20	16	24	23	20	16	24	23	20	16	24	23	20	16	24	23	20	16	22	21	19	15	22	21	19	15												
	kW	6.24	6.36	6.55	6.75	6.69	6.82	7.03	7.25	7.08	7.23	7.45	7.69	7.43	7.59	7.83	8.07	7.73	7.89	8.14	8.40	7.73	7.89	8.14	8.40	7.99	8.16	8.42	8.69	7.99	8.16	8.42	8.69												
	Hi PR	236	254	268	280	265	285	301	314	301	324	342	357	343	369	390	407	386	415	439	458	386	415	439	458	427	459	485	506	427	459	485	506												
Lo PR	109	116	127	135	116	123	134	143	120	128	139	149	126	134	147	156	132	141	154	164	132	141	154	164	137	145	159	169	137	145	159	169													
2400	MBh	81.8	83.6	89.3	95.5	79.9	81.6	87.2	93.2	78.0	79.7	85.1	91.0	76.1	77.8	83.1	88.8	72.3	73.9	78.9	84.4	72.3	73.9	78.9	84.4	67.0	68.4	73.1	78.1	67.0	68.4	73.1	78.1												
	S/T	0.84	0.79	0.64	0.48	0.87	0.82	0.67	0.50	0.89	0.84	0.68	0.51	0.92	0.86	0.70	0.53	0.96	0.90	0.73	0.55	0.96	0.90	0.73	0.55	0.97	0.91	0.74	0.55	0.97	0.91	0.74	0.55												
	ΔT	26	25	22	18	27	26	22	18	27	26	22	18	27	26	22	18	27	25	22	18	27	25	22	18	25	24	21	16	25	24	21	16												
	kW	6.10	6.22	6.40	6.60	6.54	6.67	6.87	7.08	6.92	7.06	7.28	7.50	7.26	7.41	7.64	7.88	7.55	7.71	7.95	8.20	7.55	7.71	7.95	8.20	7.80	7.96	8.21	8.48	7.80	7.96	8.21	8.48												
	Hi PR	229	246	260	271	257	277	292	305	292	315	332	346	333	358	378	395	375	403	426	444	375	403	426	444	414	445	470	490	414	445	470	490												
Lo PR	106	113	123	131	112	119	130	139	116	124	135	144	122	130	142	151	128	136	149	159	128	136	149	159	133	141	154	164	133	141	154	164													

3375	MBh	92.9	94.7	99.2	105.8	90.7	92.5	96.8	103.3	88.6	90.3	94.5	100.9	86.4	88.1	92.2	98.4	82.1	83.7	87.6	93.5	82.1	83.7	87.6	93.5	76.0	77.5	81.2	86.6	76.0	77.5	81.2	86.6
	S/T	0.96	0.92	0.83	0.68	0.99	0.96	0.86	0.70	1.00	0.98	0.89	0.72	1.00	1.00	0.92	0.74	1.00	1.00	0.95	0.77	1.00	1.00	0.95	0.77	1.00	1.00	0.96	0.78	1.00	1.00	0.96	0.78
	ΔT	24	24	23	20	25	24	23	20	24	24	23	20	24	24	23	20	24	23	23	20	22	23	23	20	21	21	21	18	21	21	18	
	kW	6.33	6.46	6.65	6.85	6.79	6.93	7.14	7.36	7.19	7.34	7.57	7.81	7.55	7.71	7.95	8.20	7.85	8.02	8.27	8.54	7.85	8.02	8.27	8.54	8.12	8.29	8.55	8.83	8.12	8.29	8.55	8.83
	Hi PR	241	259	274	285	270	291	307	320	307	331	349	364	350	377	398	415	394	424	448	467	394	424	448	467	435	468	495	516	435	468	495	516
Lo PR	112	119	130	138	118	125	137	146	122	130	142	152	129	137	149	159	135	143	157	167	135	143	157	167	139	148	162	173	139	148	162	173	
3000	MBh	90.2	91.9	96.3	102.7	88.1	89.8	94.0	100.3	86.0	87.6	91.8	97.9	83.9	85.5	89.6	95.5	79.7	81.2	85.1	90.8	79.7	81.2	85.1	90.8	73.8	75.2	78.8	84.1	73.8	75.2	78.8	84.1
	S/T	0.91	0.88	0.80	0.65	0.95	0.91	0.82	0.67	0.97	0.94	0.85	0.69	1.00	0.97	0.87	0.71	1.00	1.00	0.91	0.74	1.00	1.00	0.91	0.74	1.00	1.00	0.91	0.74	1.00	1.00	0.91	0.74
	ΔT	25	25	23	20	26	25	24	21	26	25	24	21	26	25	24	21	26	25	24	21	24	25	24	21	24	23	22	19	23	22	19	
	kW	6.29	6.41	6.60	6.80	6.74	6.88	7.08	7.30	7.14	7.29	7.51	7.75	7.49	7.65	7.89	8.14	7.79	7.96	8.21	8.47	7.79	7.96	8.21	8.47	8.05	8.22	8.48	8.76	8.05	8.22	8.48	8.76
	Hi PR	238	257	271	283	268	288	304	317	304	328	346	361	347	373	394	411	390	420	443	462	390	420	443	462	431	464	490	511	431	464	490	511
Lo PR	110	118	128	137	117	124	136	144	121	129	141	150	127	136	148	158	134	142	155	165	134	142	155	165	138	147	160	171	138	147	160	171	
2400	MBh	83.2	84.8	88.9	94.8	81.3	82.9	86.8	92.6	79.4	80.9	84.7	90.4	77.4	78.9	82.7	88.2	73.6	75.0	78.5	83.8	73.6	75.0	78.5	83.8	68.1	69.4	72.7	77.6	68.1	69.4	72.7	77.6
	S/T	0.88	0.85	0.77	0.62	0.91	0.88	0.80	0.65	0.94	0.90	0.82	0.66	0.97	0.93	0.84	0.68	1.00	0.97	0.87	0.71	1.00	0.97	0.87	0.71	1.00	0.98	0.88	0.71	1.00	0.98	0.88	0.71
	ΔT	28	28	26	23	28	28	26	23	28	28	26	23	29	28	27	23	28	28	26	23	28	28	26	23	26	26	25	21	26	26	25	21
	kW	6.15	6.27	6.45	6.65	6.59	6.72	6.92	7.13	6.97	7.12	7.33	7.56	7.32	7.47	7.70	7.94	7.61	7.77	8.01	8.27	7.61	7.77	8.01	8.27	7.86	8.02	8.28	8.55	7.86	8.02	8.28	8.55
	Hi PR	231	249	263	274	260	279	295	308	295	318	335	350	336	362	382	399	378	407	430	448	378	407	430	448	418	450	475	495	418	450	475	495
Lo PR	107	114	124	133	113	120	131	140	118	125	137	146	124	131	144	153	130	138	150	160	130	138	150	160	134	143	156	166	134	143	156	166	

IDB: Entering Indoor Dry Bulb Temperature
 High and low pressures are measured at the liquid and suction access fittings.
 Design Superheat 7±2 °F, Design Subcooling 12±2 °F pressures measured @ the suction and liquid service ports, AHRI 95 test conditions
 Shaded area reflects AHRI Rating Conditions

IDB		OUTDOOR AMBIENT TEMPERATURE																							
		65				75				85				95				105				115			
		59	63	67	71	59	63	67	71	59	63	67	71	59	63	67	71	59	63	67	71	59	63	67	71
AIRFLOW		ENTERING INDOOR WET BULB TEMPERATURE																							
	MBh	100.0	103.6	113.5	-	97.6	101.2	110.9	-	95.3	98.8	108.2	-	93.0	96.4	105.6	-	88.3	91.6	100.3	-	81.8	84.8	92.9	-
	S/T	0.73	0.61	0.42	-	0.75	0.63	0.44	-	0.77	0.64	0.45	-	0.80	0.67	0.46	-	0.83	0.69	0.48	-	0.83	0.70	0.48	-
	ΔT	17	15	11	-	18	15	12	-	18	15	12	-	18	15	12	-	18	15	12	-	16	14	11	-
3820	kW	7.18	7.32	7.53	-	7.69	7.84	8.07	-	8.13	8.29	8.54	-	8.52	8.69	8.96	-	8.85	9.03	9.31	-	9.14	9.33	9.62	-
	HI PR	238	256	270	-	267	287	303	-	303	326	345	-	345	372	392	-	389	418	442	-	429	462	488	-
	LO PR	106	113	123	-	112	119	130	-	116	124	135	-	122	130	142	-	128	136	149	-	133	141	154	-
	MBh	97.0	100.6	110.2	-	94.8	98.2	107.6	-	92.5	95.9	105.1	-	90.3	93.6	102.5	-	85.8	88.9	97.4	-	79.4	82.3	90.2	-
	S/T	0.69	0.58	0.40	-	0.72	0.60	0.42	-	0.74	0.62	0.43	-	0.76	0.63	0.44	-	0.79	0.66	0.46	-	0.80	0.66	0.46	-
	ΔT	18	16	12	-	18	16	12	-	18	16	12	-	19	16	12	-	18	16	12	-	17	15	11	-
3400	kW	7.13	7.27	7.48	-	7.63	7.78	8.01	-	8.07	8.23	8.47	-	8.45	8.63	8.89	-	8.78	8.96	9.24	-	9.07	9.25	9.54	-
	HI PR	235	253	267	-	264	284	300	-	300	323	341	-	342	368	389	-	385	414	437	-	425	457	483	-
	LO PR	105	112	122	-	111	118	129	-	115	123	134	-	121	129	141	-	127	135	147	-	131	140	152	-
	MBh	89.6	92.8	101.7	-	87.5	90.7	99.3	-	85.4	88.5	97.0	-	83.3	86.4	94.6	-	79.2	82.0	89.9	-	73.3	76.0	83.3	-
	S/T	0.67	0.56	0.39	-	0.69	0.58	0.40	-	0.71	0.59	0.41	-	0.73	0.61	0.42	-	0.76	0.64	0.44	-	0.77	0.64	0.44	-
	ΔT	18	16	12	-	19	16	12	-	19	16	12	-	19	16	12	-	19	16	12	-	17	15	11	-
2980	kW	6.98	7.11	7.31	-	7.46	7.61	7.83	-	7.89	8.04	8.28	-	8.26	8.43	8.68	-	8.58	8.75	9.02	-	8.85	9.04	9.31	-
	HI PR	228	246	259	-	256	276	291	-	291	313	331	-	332	357	377	-	373	402	424	-	412	444	469	-
	LO PR	102	108	118	-	108	114	125	-	112	119	130	-	117	125	136	-	123	131	143	-	127	135	148	-

	MBh	101.6	104.7	113.3	121.6	99.3	102.2	110.6	118.8	96.9	99.8	108.0	115.9	94.6	97.4	105.4	113.1	89.8	92.5	100.1	107.4	83.2	85.7	92.7	99.5
	S/T	0.83	0.74	0.56	0.36	0.86	0.77	0.58	0.37	0.88	0.79	0.59	0.38	0.91	0.81	0.61	0.39	0.94	0.84	0.64	0.41	0.95	0.85	0.64	0.41
	ΔT	20	19	15	11	20	19	15	11	20	19	15	11	21	19	16	11	20	19	15	11	19	17	14	10
3820	kW	7.24	7.38	7.59	7.81	7.74	7.90	8.13	8.37	8.19	8.36	8.61	8.87	8.58	8.76	9.03	9.31	8.92	9.10	9.38	9.68	9.21	9.40	9.69	10.00
	HI PR	240	258	273	284	269	290	306	319	306	330	348	363	349	375	396	414	392	422	446	465	434	467	493	514
	LO PR	107	114	124	132	113	120	131	140	118	125	137	145	123	131	143	153	129	138	150	160	134	142	155	166
	MBh	98.7	101.6	110.0	118.0	96.4	99.2	107.4	115.3	94.1	96.9	104.9	112.5	91.8	94.5	102.3	109.8	87.2	89.8	97.2	104.3	80.8	83.2	90.0	96.6
	S/T	0.79	0.70	0.53	0.34	0.82	0.73	0.55	0.36	0.84	0.75	0.57	0.36	0.86	0.77	0.58	0.38	0.90	0.80	0.61	0.39	0.90	0.81	0.61	0.39
	ΔT	21	19	16	11	21	20	16	11	21	20	16	11	21	20	16	11	21	19	16	11	20	18	15	10
3400	kW	7.19	7.32	7.53	7.75	7.69	7.84	8.07	8.31	8.13	8.29	8.54	8.80	8.52	8.69	8.96	9.24	8.85	9.03	9.31	9.60	9.14	9.33	9.62	9.92
	HI PR	238	256	270	282	267	287	303	316	303	326	345	359	345	372	393	409	389	418	442	461	429	462	488	509
	LO PR	106	113	123	131	112	119	130	139	116	124	135	144	122	130	142	151	128	136	149	159	133	141	154	164
	MBh	91.1	93.8	101.5	108.9	89.0	91.6	99.1	106.4	86.8	89.4	96.8	103.9	84.7	87.2	94.4	101.3	80.5	82.9	89.7	96.3	74.6	76.8	83.1	89.2
	S/T	0.76	0.68	0.51	0.33	0.79	0.70	0.53	0.34	0.81	0.72	0.55	0.35	0.83	0.75	0.56	0.36	0.86	0.77	0.59	0.38	0.87	0.78	0.59	0.38
	ΔT	21	20	16	11	22	20	16	11	22	20	16	11	22	20	16	11	21	20	16	11	20	18	15	10
2980	kW	7.03	7.16	7.37	7.58	7.52	7.66	7.89	8.12	7.95	8.10	8.34	8.60	8.32	8.49	8.75	9.02	8.65	8.82	9.09	9.38	8.92	9.11	9.39	9.68
	HI PR	231	248	262	273	259	278	294	307	294	317	334	349	335	361	381	397	377	406	428	447	416	448	473	494
	LO PR	103	109	119	127	109	116	126	134	113	120	131	140	119	126	138	147	124	132	144	154	129	137	149	159

IDB: Entering Indoor Dry Bulb Temperature
 High and low pressures are measured at the liquid and suction access fittings.
 Design Superheat 7±2 °F, Design Subcooling 12±2 °F, pressures measured @ the suction and liquid service ports, AHR1 95 test conditions
 Shaded area reflects ACCA (TVA) Rating Conditions

IDB		OUTDOOR AMBIENT TEMPERATURE																							
		65				75				85				95				105				115			
		59	63	67	71	59	63	67	71	59	63	67	71	59	63	67	71	59	63	67	71	59	63	67	71
AIRFLOW		59	63	67	71	59	63	67	71	59	63	67	71	59	63	67	71	59	63	67	71	59	63	67	71
		103.5	105.7	112.9	120.7	101.0	103.3	110.3	117.9	98.6	100.8	107.7	115.1	96.2	98.3	105.1	112.3	91.4	93.4	99.8	106.7	84.7	86.5	92.5	98.8
MBh		0.91	0.85	0.69	0.52	0.94	0.88	0.72	0.54	0.96	0.90	0.73	0.55	1.00	0.93	0.76	0.57	1.00	0.97	0.79	0.59	1.00	1.00	0.79	0.59
S/T		23	22	19	15	23	22	19	15	23	22	19	15	23	22	19	15	22	22	19	15	20	21	18	14
ΔT		7.29	7.43	7.65	7.87	7.80	7.96	8.19	8.44	8.25	8.42	8.67	8.94	8.65	8.83	9.10	9.38	8.99	9.18	9.46	9.76	9.28	9.48	9.77	10.08
kW		242	261	276	287	272	293	309	322	309	333	352	367	352	379	400	418	396	427	451	470	438	471	498	519
HI PR		108	115	126	134	114	122	133	141	119	126	138	147	125	133	145	154	131	139	152	162	135	144	157	167
LO PR		100.4	102.6	109.7	117.2	98.1	100.2	107.1	114.5	95.8	97.9	104.6	111.8	93.4	95.5	102.0	109.0	88.8	90.7	96.9	103.6	82.2	84.0	89.8	96.0
		0.86	0.81	0.66	0.49	0.90	0.84	0.68	0.51	0.92	0.86	0.70	0.52	0.95	0.89	0.72	0.54	0.98	0.92	0.75	0.56	0.99	0.93	0.76	0.57
S/T		23	22	20	16	24	23	20	16	24	23	20	16	24	23	20	16	24	23	20	16	22	21	18	15
ΔT		7.24	7.38	7.59	7.81	7.74	7.90	8.13	8.37	8.19	8.36	8.61	8.87	8.59	8.76	9.03	9.31	8.92	9.11	9.39	9.68	9.21	9.40	9.69	10.00
kW		240	258	273	285	269	290	306	319	306	330	348	363	349	375	397	414	393	422	446	465	434	467	493	514
HI PR		107	114	124	132	113	120	131	140	118	125	137	145	124	131	143	153	129	138	150	160	134	142	155	166
LO PR		92.7	94.7	101.2	108.2	90.5	92.5	98.9	105.7	88.4	90.3	96.5	103.2	86.2	88.1	94.1	100.6	81.9	83.7	89.4	95.6	75.9	77.5	82.8	88.6
		0.83	0.78	0.64	0.48	0.86	0.81	0.66	0.49	0.89	0.83	0.68	0.51	0.91	0.86	0.70	0.52	0.95	0.89	0.72	0.54	0.96	0.90	0.73	0.55
S/T		24	23	20	16	24	23	20	16	24	23	20	16	24	23	20	16	24	23	20	16	22	21	19	15
ΔT		7.08	7.22	7.42	7.64	7.57	7.72	7.95	8.18	8.01	8.17	8.41	8.66	8.39	8.56	8.82	9.09	8.71	8.89	9.16	9.45	8.99	9.18	9.46	9.76
kW		233	251	265	276	261	281	297	310	297	320	338	352	338	364	385	401	381	410	433	451	421	453	478	499
HI PR		104	111	121	128	110	117	127	136	114	121	132	141	120	127	139	148	126	134	146	155	130	138	151	161
LO PR		105.3	107.3	112.4	119.9	102.8	104.8	109.8	117.1	100.4	102.3	107.1	114.3	97.9	99.8	104.5	111.5	93.0	94.8	99.3	105.9	86.2	87.8	92.0	98.1
		0.95	0.92	0.83	0.67	0.98	0.95	0.86	0.70	1.00	0.97	0.88	0.71	1.00	1.00	0.91	0.74	1.00	1.00	0.94	0.76	1.00	1.00	0.95	0.77
S/T		24	24	22	19	24	24	23	20	24	24	23	20	24	24	23	20	22	23	23	19	21	21	21	18
ΔT		7.34	7.49	7.70	7.93	7.86	8.02	8.25	8.50	8.32	8.48	8.74	9.01	8.72	8.90	9.17	9.45	9.06	9.25	9.53	9.83	9.35	9.55	9.85	10.16
kW		245	264	278	290	275	296	312	326	313	336	355	370	356	383	404	422	400	431	455	475	442	476	503	524
HI PR		109	116	127	135	115	123	134	143	120	128	139	148	126	134	146	156	132	140	153	163	137	145	159	169
LO PR		102.2	104.2	109.1	116.4	99.8	101.7	106.6	113.7	97.4	99.3	104.0	111.0	95.1	96.9	101.5	108.3	90.3	92.1	96.4	102.9	83.7	85.3	89.3	95.3
		0.91	0.87	0.79	0.64	0.94	0.91	0.82	0.66	0.96	0.93	0.84	0.68	0.99	0.96	0.87	0.70	1.00	1.00	0.90	0.73	1.00	1.00	0.91	0.73
S/T		25	25	23	20	25	25	24	20	25	25	24	20	26	25	24	21	24	25	23	20	23	23	22	19
ΔT		7.29	7.43	7.65	7.87	7.80	7.96	8.19	8.44	8.25	8.42	8.67	8.94	8.65	8.83	9.10	9.38	8.99	9.18	9.46	9.76	9.28	9.48	9.77	10.08
kW		242	261	276	287	272	293	309	322	309	333	352	367	352	379	400	418	396	427	451	470	438	471	498	519
HI PR		108	115	126	134	114	122	133	141	119	126	138	147	125	133	145	154	131	139	152	162	135	144	157	167
LO PR		94.3	96.2	100.7	107.4	92.1	93.9	98.4	104.9	89.9	91.7	96.0	102.4	87.7	89.4	93.7	99.9	83.4	85.0	89.0	94.9	77.2	78.7	82.4	87.9
		0.87	0.84	0.76	0.62	0.91	0.87	0.79	0.64	0.93	0.90	0.81	0.66	0.96	0.92	0.83	0.68	0.99	0.96	0.87	0.70	1.00	0.97	0.87	0.71
S/T		25	25	24	20	26	25	24	21	26	25	24	21	26	26	24	21	26	25	24	21	24	24	23	19
ΔT		7.13	7.27	7.48	7.69	7.63	7.78	8.01	8.25	8.07	8.23	8.47	8.73	8.45	8.62	8.89	9.16	8.78	8.96	9.24	9.52	9.06	9.25	9.54	9.84
kW		235	253	267	279	264	284	300	313	300	323	341	356	342	368	388	405	385	414	437	456	425	457	483	504
HI PR		105	112	122	130	111	118	129	137	115	123	134	142	121	129	141	150	127	135	147	157	131	140	152	162
LO PR		105.3	107.3	112.4	119.9	102.8	104.8	109.8	117.1	100.4	102.3	107.1	114.3	97.9	99.8	104.5	111.5	93.0	94.8	99.3	105.9	86.2	87.8	92.0	98.1

IDB		OUTDOOR AMBIENT TEMPERATURE																							
		65				75				85				95				105				115			
		59	63	67	71	59	63	67	71	59	63	67	71	59	63	67	71	59	63	67	71	59	63	67	71
AIRFLOW		59	63	67	71	59	63	67	71	59	63	67	71	59	63	67	71	59	63	67	71	59	63	67	71
		103.5	105.7	112.9	120.7	101.0	103.3	110.3	117.9	98.6	100.8	107.7	115.1	96.2	98.3	105.1	112.3	91.4	93.4	99.8	106.7	84.7	86.5	92.5	98.8
MBh		0.91	0.85	0.69	0.52	0.94	0.88	0.72	0.54	0.96	0.90	0.73	0.55	1.00	0.93	0.76	0.57	1.00	0.97	0.79	0.59	1.00	1.00	0.79	0.59
S/T		23	22	19	15	23	22	19	15	23	22	19	15	23	22	19	15	22	22	19	15	20	21	18	14
ΔT		7.29	7.43	7.65	7.87	7.80	7.96	8.19	8.44	8.25	8.42	8.67	8.94	8.65	8.83	9.10	9.38	8.99	9.18	9.46	9.76	9.28	9.48	9.77	10.08
kW		242	261	276	287	272	293	309	322	309	333	352	367	352	379	400	418	396	427	451	470	438	471	498	519
HI PR		108	115	126	134	114	122	133	141	119	126	138	147	125	133	145	154	131	139	152	162	135	144	157	167
LO PR		100.4	102.6	109.7	117.2	98.1	100.2	107.1	114.5	95.8	97.9	104.6	111.8	93.4	95.5	102.0	109.0	88.8	90.7	96.9	103.6	82.2	84.0	89.8	96.0
		0.86	0.81	0.66	0.49	0.90	0.84	0.68	0.51	0.92	0.86	0.70	0.52	0.95	0.89	0.72	0.54	0.98	0.92	0.75	0.56	0.99	0.93	0.76	0.57
S/T		23	22	20	16	24	23	20	16	24	23	20	16	24	23	20	16	24	23	20	16	22	21	18	15
ΔT		7.24	7.38	7.59	7.81	7.74	7.90	8.13	8.37	8.19	8.36	8.61	8.87	8.59	8.76	9.03	9.31	8.92	9.11	9.39	9.68	9.21	9.40	9.69	10.00
kW		240	258	273	285	269	290	306	319	306	330	348	363	349	375	397	414	393	422	446	465	434	467	493	514
HI PR		107	114	124	132	113	120	131	140	118	125	137	145	124	131	143	153	129	138	150	160	134	142	155	166
LO PR		92.7	94.7	101.2	108.2	90.5	92.5	98.9	105.7	88.4	90.3	96.5	103.2	86.2	88.1	94.1	100.6	81.9	83.7	89					

IDB		OUTDOOR AMBIENT TEMPERATURE																																															
		65								75								85								95								105								115							
		AIRFLOW						ENTERING INDOOR WET BULB TEMPERATURE						ENTERING INDOOR WET BULB TEMPERATURE						ENTERING INDOOR WET BULB TEMPERATURE						ENTERING INDOOR WET BULB TEMPERATURE						ENTERING INDOOR WET BULB TEMPERATURE																	
59	63	67	71	59	63	67	71	59	63	67	71	59	63	67	71	59	63	67	71	59	63	67	71	59	63	67	71	59	63	67	71	59	63	67	71	59	63	67	71										
70	MBh	114	118	129	-	111	115	126	-	108	112	123	-	106	110	120	-	100	104	114	-	93	96	106	-	100	104	114	-	93	96	106	-	100	104	114	-	93	96	106	-	100	104	114	-	93	96	106	-
	S/T	0.73	0.61	0.42	-	0.76	0.63	0.44	-	0.78	0.65	0.45	-	0.80	0.67	0.47	-	0.83	0.70	0.48	-	0.84	0.70	0.49	-	0.83	0.70	0.48	-	0.84	0.70	0.49	-	0.83	0.70	0.48	-	0.84	0.70	0.49	-	0.83	0.70	0.48	-	0.84	0.70	0.49	-
	ΔT	19	17	13	-	20	17	13	-	20	17	13	-	20	17	13	-	20	17	13	-	18	16	12	-	20	17	13	-	18	16	12	-	20	17	13	-	18	16	12	-	20	17	13	-	18	16	12	-
	kW	8.22	8.37	8.60	-	8.77	8.94	9.19	-	9.25	9.43	9.70	-	9.68	9.87	10.16	-	10.04	10.24	10.55	-	10.36	10.56	10.88	-	10.04	10.24	10.55	-	10.36	10.56	10.88	-	10.04	10.24	10.55	-	10.36	10.56	10.88	-	10.04	10.24	10.55	-	10.36	10.56	10.88	-
	Hi PR	247	266	281	-	277	298	315	-	315	339	358	-	359	386	408	-	404	435	459	-	446	480	507	-	404	435	459	-	446	480	507	-	404	435	459	-	446	480	507	-	404	435	459	-	446	480	507	-
	Lo PR	105	111	122	-	111	118	128	-	115	122	134	-	121	128	140	-	127	135	147	-	131	139	152	-	127	135	147	-	131	139	152	-	127	135	147	-	131	139	152	-	127	135	147	-	131	139	152	-
MBh	110	114	125	-	108	112	122	-	105	109	119	-	103	106	117	-	98	101	111	-	90	94	103	-	98	101	111	-	90	94	103	-	98	101	111	-	90	94	103	-	98	101	111	-	90	94	103	-	
S/T	0.70	0.58	0.40	-	0.72	0.61	0.42	-	0.74	0.62	0.43	-	0.77	0.64	0.44	-	0.80	0.66	0.46	-	0.80	0.67	0.46	-	0.80	0.66	0.46	-	0.80	0.67	0.46	-	0.80	0.66	0.46	-	0.80	0.67	0.46	-	0.80	0.66	0.46	-	0.80	0.67	0.46	-	
ΔT	20.27	17.55	13.32	-	20.52	17.76	13.48	-	20.54	17.78	13.50	-	20.69	17.91	13.59	-	20.40	17.66	13.40	-	19.05	16.49	12.52	-	20.40	17.66	13.40	-	19.05	16.49	12.52	-	20.40	17.66	13.40	-	19.05	16.49	12.52	-	20.40	17.66	13.40	-	19.05	16.49	12.52	-	
kW	8.2	8.3	8.5	-	8.7	8.9	9.1	-	9.2	9.4	9.6	-	9.6	9.8	10.1	-	10.0	10.2	10.5	-	10.3	10.5	10.8	-	10.0	10.2	10.5	-	10.3	10.5	10.8	-	10.0	10.2	10.5	-	10.3	10.5	10.8	-	10.0	10.2	10.5	-	10.3	10.5	10.8	-	
Hi PR	245	263	278	-	274	295	312	-	312	336	355	-	355	383	404	-	400	430	454	-	442	476	502	-	400	430	454	-	442	476	502	-	400	430	454	-	442	476	502	-	400	430	454	-	442	476	502	-	
Lo PR	104	110	120	-	110	117	127	-	114	121	132	-	120	127	139	-	125	133	146	-	130	138	151	-	125	133	146	-	130	138	151	-	125	133	146	-	130	138	151	-	125	133	146	-	130	138	151	-	
MBh	102	106	116	-	99	103	113	-	97	101	110	-	95	98	108	-	90	93	102	-	83	86	95	-	90	93	102	-	83	86	95	-	90	93	102	-	83	86	95	-	90	93	102	-	83	86	95	-	
S/T	0.67	0.56	0.39	-	0.70	0.58	0.40	-	0.72	0.60	0.41	-	0.74	0.62	0.43	-	0.77	0.64	0.44	-	0.77	0.65	0.45	-	0.77	0.64	0.44	-	0.77	0.65	0.45	-	0.77	0.64	0.44	-	0.77	0.65	0.45	-	0.77	0.64	0.44	-	0.77	0.65	0.45	-	
ΔT	23	20	15	-	23	20	15	-	23	20	15	-	23	20	15	-	23	20	15	-	21	18	14	-	23	20	15	-	21	18	14	-	23	20	15	-	21	18	14	-	23	20	15	-	21	18	14	-	
kW	8	8	8	-	9	9	9	-	9	9	9	-	9	9	9	-	9	9	9	-	10	10	11	-	9	9	9	-	10	10	11	-	9	9	9	-	10	10	11	-	9	9	9	-	10	10	11	-	
Hi PR	237	255	270	-	266	286	302	-	303	326	344	-	345	371	392	-	388	417	441	-	429	461	487	-	388	417	441	-	429	461	487	-	388	417	441	-	429	461	487	-	388	417	441	-	429	461	487	-	
Lo PR	101	107	117	-	106	113	123	-	110	117	128	-	116	123	135	-	122	129	141	-	126	134	146	-	122	129	141	-	126	134	146	-	122	129	141	-	126	134	146	-	122	129	141	-	126	134	146	-	

75	MBh	116	119	129	138	113	116	126	135	110	113	123	132	108	111	120	129	102	105	114	122	95	97	105	113	102	105	114	122	95	97	105	113	102	105	114	122	95	97	105	113	102	105	114	122	95	97	105	113
	S/T	0.83	0.75	0.56	0.4	0.86	0.77	0.58	0.4	0.89	0.79	0.60	0.4	0.91	0.82	0.62	0.4	0.95	0.85	0.64	0.4	0.96	0.86	0.65	0.4	0.95	0.85	0.64	0.4	0.96	0.86	0.65	0.4	0.95	0.85	0.64	0.4	0.96	0.86	0.65	0.4	0.95	0.85	0.64	0.4	0.96	0.86	0.65	0.4
	ΔT	22.5	20.7	17.0	11.7	22.8	21.0	17.2	11.9	22.8	21.0	17.2	11.9	23.0	21.1	17.3	12.0	22.6	20.8	17.1	11.8	21.1	19.5	15.9	11.0	22.6	20.8	17.1	11.8	21.1	19.5	15.9	11.0	22.6	20.8	17.1	11.8	21.1	19.5	15.9	11.0	22.6	20.8	17.1	11.8	21.1	19.5	15.9	11.0
	kW	8.3	8.4	8.7	8.9	8.8	9.0	9.3	9.5	9.3	9.5	9.8	10.1	9.8	9.9	10.2	10.5	10.1	10.3	10.6	10.9	10.4	10.6	11.0	11.3	10.1	10.3	10.6	10.9	10.4	10.6	11.0	11.3	10.1	10.3	10.6	10.9	10.4	10.6	11.0	11.3	10.1	10.3	10.6	10.9	10.4	10.6	11.0	11.3
	Hi PR	250	269	284	296	280	301	318	332	318	343	362	377	363	390	412	430	408	439	464	484	451	485	512	534	408	439	464	484	451	485	512	534	408	439	464	484	451	485	512	534	408	439	464	484	451	485	512	534
	Lo PR	106	113	123	131	112	119	130	138	116	124	135	144	122	130	142	151	128	136	148	158	132	141	154	164	128	136	148	158	132	141	154	164	128	136	148	158	132	141	154	164	128	136	148	158	132	141	154	164
MBh	112	116	125	134	110	113	122	131	107	110	119	128	104	107	116	125	99	102	111	119	92	95	102	110	99	102	111	119	92	95	102	110	99	102	111	119	92	95	102	110	99	102	111	119	92	95	102	110	
S/T	0.79	0.71	0.54	0.3	0.82	0.74	0.56	0.4	0.84	0.76	0.57	0.4	0.87	0.78	0.59	0.4	0.90	0.81	0.61	0.4	0.91	0.82	0.62	0.4	0.90	0.81	0.61	0.4	0.91	0.82	0.62	0.4	0.90	0.81	0.61	0.4	0.91	0.82	0.62	0.4	0.90	0.81	0.61	0.4	0.91	0.82	0.62	0.4	
ΔT	23.4	21.6	17.7	12.2	23.7	21.8	17.9	12.4	23.7	21.9	17.9	12.4	23.9	22.0	18.0	12.5	23.6	21.7	17.8	12.3	22.0	20.3	16.6	11.5	23.6	21.7	17.8	12.3	22.0	20.3	16.6	11.5	23.6	21.7	17.8	12.3	22.0	20.3	16.6	11.5	23.6	21.7	17.8	12.3	22.0	20.3	16.6	11.5	
kW	8.2	8.4	8.6	8.8	8.8	8.9	9.2	9.5	9.3	9.4	9.7	10.0	9.7	9.9	10.2	10.5	10.0	10.2	10.5	10.9	10.4	10.6	10.9	11.2	10.0	10.2	10.5	10.9	10.4	10.6	10.9	11.2	10.0	10.2	10.5	10.9	10.4	10.6	10.9	11.2	10.0	10.2	10.5	10.9	10.4	10.6	10.9	11.2	
Hi PR	247	266	281	293	277	298	315	329	315	339	358	374	359	386	408	426	404	435	459	479	446	480	507	529	404	435	459	479	446	480	507	529	404	435	459	479	446	480	507	529	404	435	459	479	446	480	507	529	
Lo PR	105	111	122	130	111	118	128	137	115	122	134	142	121	128	140	149	127	135	147	157	131	139	152	162	127	135	147	157	131	139	152	162	127	135	147	157	131	139	152	162	127	135	147						

IDB		OUTDOOR AMBIENT TEMPERATURE																																		
		65					75					85					95					105					115									
		59	63	67	71	75	59	63	67	71	75	59	63	67	71	75	59	63	67	71	75	59	63	67	71	75	59	63	67	71	75					
AIRFLOW		59	63	67	71	75	59	63	67	71	75	59	63	67	71	75	59	63	67	71	75	59	63	67	71	75	59	63	67	71	75	59	63	67	71	75
3938		118	120	128	137	145	115	117	125	134	142	112	115	122	131	139	109	112	119	128	136	104	106	114	121	129	104	106	114	121	129	104	106	114	121	129
S/T		0.91	0.86	0.70	0.5	0.3	0.95	0.89	0.72	0.5	0.3	1.00	0.91	0.74	0.6	0.4	1.00	0.94	0.77	0.6	0.4	1.00	1.00	0.79	0.6	0.4	1.00	1.00	0.79	0.6	0.4	1.00	1.00	0.79	0.6	0.4
ΔT		25.1	24.1	20.9	16.7	12.5	25.4	24.4	21.2	16.9	12.6	26.2	24.4	21.2	16.9	12.6	25.6	24.6	21.4	17.1	12.8	24.3	24.8	21.1	16.8	12.5	24.3	24.8	21.1	16.8	12.5	22.5	23.0	19.7	15.7	11.4
kW		8.34	8.49	8.73	9.0	9.3	8.90	9.07	9.32	9.6	9.9	9.39	9.57	9.85	10.1	10.4	9.83	10.02	10.31	10.6	10.9	10.20	10.40	10.71	11.0	11.4	10.20	10.40	10.71	11.0	11.4	10.52	10.73	11.05	11.4	11.8
Hi PR		252	271	286	299	312	283	304	321	335	348	322	346	366	381	394	366	394	416	434	448	412	444	468	489	507	412	444	468	489	507	455	490	517	540	564
Lo PR		107	114	124	132	140	113	120	131	140	149	117	125	136	145	154	123	131	143	152	161	129	137	150	160	170	129	137	150	160	170	134	142	155	165	175
80		114	117	125	133	141	112	114	122	130	138	109	111	119	127	135	106	109	116	124	132	101	103	110	118	126	101	103	110	118	126	94	96	102	109	117
S/T		0.87	0.82	0.67	0.50	0.33	0.90	0.85	0.69	0.52	0.35	0.93	0.87	0.71	0.53	0.37	0.96	0.90	0.73	0.55	0.39	0.99	0.93	0.76	0.57	0.41	0.99	0.93	0.76	0.57	0.41	1.00	0.94	0.76	0.57	0.41
ΔT		26.16	25.07	21.80	17.4	13.0	26.48	25.38	22.07	17.6	13.2	26.51	25.40	22.09	17.6	13.2	26.69	25.58	22.24	17.8	13.4	26.32	25.22	21.93	17.5	13.1	26.32	25.22	21.93	17.5	13.1	24.56	23.56	20.49	16.4	11.3
kW		8.3	8.4	8.7	8.9	9.1	8.8	9.0	9.3	9.5	9.7	9.3	9.5	9.8	10.1	10.3	9.8	9.9	10.2	10.5	10.7	10.1	10.3	10.6	11.0	11.3	10.1	10.3	10.6	11.0	11.3	10.4	10.6	11.0	11.3	11.6
Hi PR		250	269	284	296	308	280	301	318	332	346	318	343	362	377	391	363	390	412	430	444	408	439	464	484	504	408	439	464	484	504	451	485	512	534	558
Lo PR		106	113	123	131	139	112	119	130	138	146	116	124	135	144	152	122	130	142	151	160	128	136	149	158	167	128	136	149	158	167	132	141	154	164	174
80		105	108	115	123	131	103	105	112	120	128	101	103	110	117	125	98	100	107	114	122	93	95	102	109	117	93	95	102	109	117	86	88	94	101	109
S/T		0.84	0.79	0.64	0.5	0.36	0.87	0.82	0.67	0.5	0.37	0.89	0.84	0.68	0.5	0.38	0.92	0.86	0.70	0.5	0.39	0.96	0.90	0.73	0.5	0.41	0.96	0.90	0.73	0.5	0.41	0.97	0.91	0.74	0.6	0.5
ΔT		29	28	24	19.4	14.9	29	28	25	19.6	15.1	29	28	25	19.6	15.1	30	28	25	19.8	15.3	29	28	24	19.5	14.9	29	28	24	19.5	14.9	27	26	23	18.2	13.0
kW		8.1	8.3	8.5	8.7	8.9	8.6	8.8	9.1	9.3	9.5	9.1	9.3	9.6	9.8	10.0	9.5	9.7	10.0	10.3	10.5	9.9	10.1	10.4	10.7	11.0	9.9	10.1	10.4	10.7	11.0	10.2	10.4	10.7	11.0	11.3
Hi PR		242	261	275	287	299	272	292	309	322	336	309	332	351	366	380	352	379	400	417	431	396	426	450	469	483	396	426	450	469	483	437	471	497	518	532
Lo PR		103	109	119	127	135	108	115	126	134	142	113	120	131	139	147	118	126	137	146	154	124	132	144	153	161	124	132	144	153	161	128	136	149	159	167

IDB		OUTDOOR AMBIENT TEMPERATURE																																							
		65					75					85					95					105					115														
		59	63	67	71	75	59	63	67	71	75	59	63	67	71	75	59	63	67	71	75	59	63	67	71	75	59	63	67	71	75										
AIRFLOW		59	63	67	71	75	59	63	67	71	75	59	63	67	71	75	59	63	67	71	75	59	63	67	71	75	59	63	67	71	75	59	63	67	71	75	59	63	67	71	75
3938		120	122	128	136	144	117	119	125	133	141	114	116	122	130	138	111	114	119	127	135	106	108	113	120	128	106	108	113	120	128	98	100	105	112	120					
S/T		0.96	0.92	0.83	0.7	0.57	0.99	0.96	0.86	0.7	0.58	1.00	0.98	0.89	0.7	0.6	1.00	1.00	0.92	0.7	0.6	1.00	1.00	0.95	0.8	0.7	1.00	1.00	0.95	0.8	0.7	1.00	1.00	0.96	0.8	0.7					
ΔT		26.8	26.3	24.9	21.6	17.2	27.1	26.7	25.2	21.8	17.4	26.7	26.7	25.2	21.8	17.4	26.0	26.5	25.4	22.0	17.6	24.7	25.2	25.1	21.7	17.3	24.7	25.2	25.1	21.7	17.3	22.9	23.3	23.4	20.3	15.1					
kW		8.40	8.55	8.79	9.0	9.3	8.96	9.13	9.39	9.7	10.0	9.46	9.64	9.92	10.2	10.5	9.90	10.09	10.39	10.7	11.0	10.27	10.48	10.79	11.1	11.5	10.27	10.48	10.79	11.1	11.5	10.59	10.81	11.13	11.5	11.9					
Hi PR		255	274	289	302	316	286	307	325	339	353	325	350	369	385	399	370	398	420	439	453	416	448	473	493	507	416	448	473	493	507	460	495	523	545	569					
Lo PR		108	115	125	133	141	114	121	132	141	149	118	126	138	147	155	124	132	145	154	162	130	139	151	161	170	130	139	151	161	170	135	144	157	167	177					
85		116	118	124	132	140	114	116	121	129	137	111	113	118	126	134	108	110	115	123	131	103	105	110	117	125	103	105	110	117	125	95	97	102	108	116					
S/T		0.91	0.88	0.80	0.65	0.51	0.95	0.91	0.82	0.67	0.53	0.97	0.94	0.85	0.69	0.55	1.00	0.97	0.87	0.71	0.57	1.00	1.00	0.91	0.74	0.6	1.00	1.00	0.91	0.74	0.6	1.00	1.00	0.91	0.74	0.6					
ΔT		27.90	27.44	25.94	22.5	18.1	28.24	27.78	26.26	22.7	18.3	28.27	27.81	26.28	22.8	18.4	28.40	28.00	26.47	22.9	18.5	26.98	27.50	26.10	22.6	18.2	26.98	27.50	26.10	22.6	18.2	24.99	25.47	24.38	21.1	16.7					
kW		8.3	8.5	8.7	9.0	9.3	8.9	9.1	9.3	9.6	9.9	9.4	9.6	9.8	10.1	10.4	9.8	10.0	10.3	10.6	10.9	10.2	10.4	10.7	11.0	11.4	10.2	10.4	10.7	11.0	11.4	10.5	10.7	11.0	11.4	11.8					
Hi PR		252	271	286	299	312	283	304	321	335	348	322	346	366	381	394	366	394	416	434	448	412	444	468	489	507	412	444	468	489	507	455	490	517	540	564					
Lo PR		107	114	124	132	140	113	120	131	140	149	117	125	136	145	154	123	131	143	152	161	129	137	150	160	170	129	137	150	160	170	134	142	155	165	175					
85		107	109	115	122	130	105	107	112	119	127	102	104	109	116	124	100	102	107	114	122	95	97	101	108	116	95	97	101	108	116	88	90	94	100	108					
S/T		0.88	0.85	0.77	0.6	0.46	0.91	0.88	0.80	0.6	0.47	0.94	0.90	0.82	0.7	0.56	0.97	0.93	0.84	0.7	0.57	1.00	0.97	0.87	0.7	0.6	1.00	0.97	0.87	0.7	0.6	1.00	0.98	0.88	0.7	0.6					
ΔT		31.0	30.5	28.9	25.0	20.6	31.4	30.9	29.2	25.3	20.9	31.5	30.9	29.2	25.3	20.9	31.7	31.2	29.4	25.5	21.0	31.1	30.7	29.0	25.1	20.7	31.1	30.7	29.0	25.1	20.7	28.8	28.7	27.1	23.5	19.1					
kW		8.2	8.3	8.5	8.8	9.1	8.7	8.9	9.1	9.4	9.7	9.2	9.4	9.6	9.9	10.2	9.6	9.8	10.1	10.4	10.7	10.0	10.2	10.5	10.8	11.1	10.0	10.2	10.5	10.8	11.1	10.3	10.5	10.8	11.1	11.4					
Hi PR		244	263	278	290	302	274	295	312	325	338	3																													

IDB		OUTDOOR AMBIENT TEMPERATURE																													
		65					75					85					95					105					115				
		59	63	67	71	75	59	63	67	71	75	59	63	67	71	75	59	63	67	71	75	59	63	67	71	75	59	63	67	71	75
AIRFLOW		ENTERING INDOOR WET BULB TEMPERATURE																													
4500	MBh	142.0	145.1	155.0	165.7	138.7	141.7	151.4	161.9	135.4	138.3	147.8	158.0	132.1	135.0	144.2	154.1	125.5	128.2	137.0	146.4	116.2	118.8	126.9	135.7						
	S/T	0.88	0.82	0.67	0.50	0.91	0.85	0.69	0.52	0.93	0.87	0.71	0.53	0.96	0.90	0.73	0.55	1.00	0.94	0.76	0.57	1.00	0.94	0.77	0.57						
	ΔT	25	24	21	17	26	25	21	17	26	25	21	17	26	25	22	17	26	25	21	17	24	23	20	16						
	kW	10.44	10.66	11.00	11.36	11.25	11.50	11.87	12.26	11.97	12.23	12.64	13.06	12.60	12.88	13.31	13.76	13.14	13.44	13.89	14.36	13.60	13.91	14.38	14.88						
	HI PR	252	271	286	299	283	304	321	335	322	346	365	381	366	394	416	434	412	443	468	488	455	490	517	539						
LO PR	103	109	119	127	108	115	126	134	113	120	131	139	118	126	137	146	124	132	144	153	128	136	149	159							
80	MBh	137.9	140.9	150.5	160.9	134.7	137.6	147.0	157.1	131.4	134.3	143.5	153.4	128.2	131.0	140.0	149.7	121.8	124.5	133.0	142.2	112.9	115.3	123.2	131.7						
	S/T	0.84	0.78	0.64	0.48	0.87	0.81	0.66	0.49	0.89	0.83	0.68	0.51	0.92	0.86	0.70	0.52	0.95	0.89	0.73	0.54	0.96	0.90	0.73	0.55						
	ΔT	26	25	22	18	27	26	22	18	27	26	22	18	27	26	23	18	27	26	22	18	25	24	21	17						
	kW	10.35	10.58	10.91	11.27	11.16	11.40	11.77	12.16	11.87	12.13	12.53	12.95	12.50	12.78	13.20	13.65	13.03	13.32	13.77	14.24	13.49	13.80	14.26	14.75						
	HI PR	249	268	283	296	280	301	318	332	318	343	362	377	363	390	412	430	408	439	464	483	451	485	512	534						
LO PR	102	108	118	126	107	114	125	133	111	119	129	138	117	125	136	145	123	131	143	152	127	135	147	157							
3500	MBh	127.2	130.0	138.9	148.5	124.3	127.0	135.7	145.0	121.3	124.0	132.5	141.6	118.4	120.9	129.2	138.1	112.4	114.9	122.8	131.2	104.2	106.4	113.7	121.6						
	S/T	0.81	0.76	0.62	0.46	0.84	0.78	0.64	0.48	0.86	0.80	0.65	0.49	0.88	0.83	0.67	0.50	0.92	0.86	0.70	0.52	0.93	0.87	0.71	0.53						
	ΔT	27	26	22	18	27	26	23	18	27	26	23	18	27	26	23	18	27	26	23	18	25	24	21	17						
	kW	10.10	10.32	10.65	10.99	10.88	11.12	11.48	11.86	11.57	11.83	12.22	12.62	12.18	12.45	12.87	13.30	12.70	12.98	13.42	13.87	13.15	13.44	13.89	14.37						
	HI PR	242	260	275	287	271	292	309	322	309	332	351	366	352	378	400	417	396	426	450	469	437	470	497	518						
LO PR	98	105	114	122	104	111	121	129	108	115	126	134	114	121	132	140	119	127	138	147	123	131	143	152							
4500	MBh	144.5	147.3	154.2	164.6	141.1	143.8	150.7	160.7	137.8	140.4	147.1	156.9	134.4	137.0	143.5	153.1	127.7	130.1	136.3	145.4	118.3	120.6	126.3	134.7						
	S/T	0.92	0.89	0.80	0.65	0.95	0.92	0.83	0.67	0.98	0.94	0.85	0.69	1.00	0.97	0.88	0.71	1.00	1.00	0.91	0.74	1.00	1.00	0.92	0.75						
	ΔT	27	27	25	22	27	27	26	22	27	27	26	22	27	27	26	22	26	27	25	22	24	25	24	21						
	kW	10.52	10.75	11.09	11.45	11.34	11.59	11.97	12.36	12.07	12.33	12.74	13.17	12.71	12.99	13.42	13.88	13.25	13.55	14.00	14.48	13.72	14.03	14.51	15.00						
	HI PR	254	274	289	302	286	307	324	338	325	349	369	385	370	398	420	438	416	448	473	493	460	495	522	545						
LO PR	104	110	120	128	109	116	127	135	114	121	132	141	119	127	139	148	125	133	145	155	129	138	150	160							
85	MBh	140.3	143.0	149.7	159.8	137.0	139.7	146.3	156.0	133.7	136.3	142.8	152.3	130.5	133.0	139.3	148.6	124.0	126.4	132.3	141.2	114.8	117.0	122.6	130.8						
	S/T	0.88	0.85	0.76	0.62	0.91	0.88	0.79	0.64	0.93	0.90	0.81	0.66	0.96	0.93	0.84	0.68	1.00	0.96	0.87	0.70	1.00	0.97	0.88	0.71						
	ΔT	28	28	26	23	29	28	27	23	29	28	27	23	29	28	27	23	28	28	26	23	26	26	25	21						
	kW	10.44	10.66	11.00	11.36	11.25	11.50	11.87	12.26	11.97	12.23	12.64	13.06	12.60	12.88	13.31	13.76	13.14	13.44	13.89	14.36	13.60	13.91	14.38	14.88						
	HI PR	252	271	286	299	283	304	321	335	322	346	365	381	366	394	416	434	412	443	468	488	455	490	517	539						
LO PR	103	109	119	127	108	115	126	134	113	120	131	139	118	126	137	146	124	132	144	153	128	136	149	159							
3500	MBh	129.5	132.0	138.2	147.5	126.5	128.9	135.0	144.0	123.4	125.8	131.8	140.6	120.4	122.8	128.6	137.2	114.4	116.6	122.1	130.3	106.0	108.0	113.1	120.7						
	S/T	0.85	0.82	0.74	0.60	0.88	0.85	0.76	0.62	0.90	0.87	0.78	0.63	0.93	0.89	0.81	0.65	0.96	0.93	0.84	0.68	0.97	0.94	0.84	0.69						
	ΔT	29	28	27	23	29	29	27	23	29	29	27	23	29	29	27	24	29	28	27	23	27	27	25	22						
	kW	10.18	10.40	10.73	11.08	10.97	11.21	11.57	11.96	11.67	11.93	12.32	12.73	12.28	12.56	12.97	13.41	12.81	13.09	13.53	13.99	13.26	13.56	14.01	14.49						
	HI PR	244	263	278	290	274	295	312	325	312	336	354	370	355	382	404	421	400	430	454	474	442	475	502	523						
LO PR	99	106	116	123	105	112	122	130	109	116	127	135	115	122	133	142	120	128	140	149	124	132	144	154							

IDB = Entering Indoor Dry Bulb Temperature
 High & low pressures are measured at the liquid & suction service ports.

Shaded area reflects AHRI rating conditions
 Design Superheat 8±3 °F @ the compressor suction access fitting connection.
 Design Subcooling, 12±3 °F @ liquid access fitting connection AHRI 95 test conditions.

DCH090

	OUTDOOR AMBIENT TEMPERATURE																	
	65	60	55	50	47	45	40	35	30	25	20	17	15	10	5	0	-5	-10
MBh	113.1	107.1	100.8	94.2	90	87.2	81.0	74.7	56.1	51.8	47.7	45.0	43.3	38.9	34.5	30.1	25.7	21.0
T/R	34.9	33.1	31.1	29.1	27.8	26.9	25.0	23.1	17.3	16.0	14.7	13.9	13.4	12.0	10.6	9.3	7.9	6.5
kW	8.21	8.06	7.90	7.75	7.66	7.59	7.45	7.29	6.65	6.51	6.37	6.29	6.23	6.09	5.95	5.82	5.67	5.54
Amps	29.98	28.23	26.82	25.60	24.9	24.54	23.51	22.62	21.93	21.23	20.51	20.17	19.99	19.29	18.42	17.71	16.84	15.79
COP	4.0	3.9	3.7	3.6	3.4	3.4	3.2	3.0	2.5	2.3	2.2	2.1	2.0	1.9	1.7	1.5	1.3	1.1
HI PR	424	406	390	373	365	358	344	330	316	302	290	283	278	267	257	246	238	229
LO PR	134	124	117	107	101	97	89	80	72	64	56	52	51	43	37	31	27	21

DCH102

	OUTDOOR AMBIENT TEMPERATURE																	
	65	60	55	50	47	45	40	35	30	25	20	17	15	10	5	0	-5	-10
MBh	128.2	121.4	114.2	106.8	102	98.8	91.8	84.7	69.2	63.8	58.8	55.5	53.4	48.0	42.5	37.1	31.6	25.9
T/R	34.9	33.1	31.1	29.1	27.8	26.9	25.0	23.1	18.8	17.4	16.0	15.1	14.6	13.1	11.6	10.1	8.6	7.1
kW	9.34	9.17	8.99	8.82	8.72	8.64	8.48	8.30	7.83	7.66	7.50	7.41	7.34	7.17	7.01	6.85	6.68	6.52
Amps	37.57	35.17	33.25	31.57	30.6	30.13	28.71	27.51	26.55	25.60	24.63	24.16	23.91	22.95	21.77	20.79	19.61	18.17
COP	4.0	3.9	3.7	3.5	3.4	3.3	3.2	3.0	2.6	2.4	2.3	2.2	2.1	2.0	1.8	1.6	1.4	1.2
HI PR	419	401	386	369	360	354	340	326	312	298	287	280	275	264	254	244	235	227
LO PR	136	126	118	108	103	99	91	81	73	65	57	53	51	43	37	32	28	22

Above information is for nominal CFM and 70 degree indoor dry bulb. Instantaneous capacity listed.

kW = Total system power

High pressure is measured at the liquid line gauge port connection

Amps = Outdoor unit amps (comp.+fan)

Low pressure is measured at the compressor suction gauge port connection.

Design Super Heat 7°± 2 @ Suction Service Port 47 test condition

DCH120

	OUTDOOR AMBIENT TEMPERATURE																	
	65	60	55	50	47	45	40	35	30	25	20	17	15	10	5	0	-5	-10
MBh	150.8	142.8	134.4	125.6	120	116.3	108.0	99.6	87.7	81.0	74.6	70.4	67.8	60.8	53.9	47.0	40.1	32.9
T/R	34.9	33.1	31.1	29.1	27.8	26.9	25.0	23.1	20.3	18.7	17.3	16.3	15.7	14.1	12.5	10.9	9.3	7.6
kW	10.70	10.50	10.31	10.11	10.0	9.92	9.73	9.54	8.65	8.47	8.30	8.20	8.13	7.95	7.78	7.61	7.44	7.27
Amps	41.27	38.87	36.93	35.26	34.3	33.81	32.39	31.18	30.22	29.27	28.29	27.82	27.57	26.61	25.42	24.44	23.26	21.81
COP	4.1	4.0	3.8	3.6	3.5	3.4	3.2	3.1	3.0	2.8	2.6	2.5	2.4	2.2	2.0	1.8	1.6	1.3
HI PR	439	421	405	387	378	371	356	342	328	313	301	293	288	277	266	256	246	238
LO PR	133	123	115	106	100	96	89	79	71	64	56	52	50	42	37	31	27	21

DCH150

	OUTDOOR AMBIENT TEMPERATURE																	
	65	60	55	50	47	45	40	35	30	25	20	17	15	10	5	0	-5	-10
MBh	178.5	169.0	159.0	148.7	142	137.6	127.8	117.9	104.7	96.6	89.0	84.0	80.9	72.6	64.3	56.1	47.9	39.2
T/R	39.4	37.3	35.1	32.8	31.3	30.3	28.2	26.0	23.1	21.3	19.6	18.5	17.8	16.0	14.2	12.4	10.6	8.6
kW	13.89	13.64	13.39	13.14	13.0	12.89	12.65	12.40	12.36	12.10	11.85	11.70	11.60	11.34	11.09	10.85	10.59	10.34
COP	3.76	3.62	3.48	3.31	3.2	3.12	2.96	2.78	2.48	2.34	2.20	2.10	2.04	1.87	1.70	1.51	1.32	1.11
HI PR	471	452	434	415	405	398	382	367	351	336	322	315	309	297	286	274	264	255
LO PR	129	120	113	103	98	94	86	77	69	62	54	51	49	41	36	30	26	21

Above information is for nominal CFM and 70 degree indoor dry bulb. Instantaneous capacity listed.

kW = Total system power

High pressure is measured at the liquid line gauge port connection

Amps = Outdoor unit amps (comp.+fan)

Low pressure is measured at the compressor suction gauge port connection.

Design Super Heat 7°± 2 @ Suction Service Port 47 test condition

STANDARD BELT DRIVE & TWO-SPEED STANDARD BELT DRIVE AT HIGH SPEED — DOWN SHOT

ESP IN H ₂ O	TURNS OPEN																	
	0			1			2			3			4			5		
	CFM	RPM	BHP	CFM	RPM	BHP	CFM	RPM	BHP	CFM	RPM	BHP	CFM	RPM	BHP	CFM	RPM	BHP
0.1	---	---	---	---	---	---	---	---	---	---	---	---	3617	704	1.07	3293	653	0.84
0.3	---	---	---	---	---	---	---	---	---	3541	749	1.15	3179	704	0.88	2757	656	0.66
0.5	---	---	---	---	---	---	3447	798	1.23	3049	754	0.94	2606	710	0.71	---	---	---
0.7	---	---	---	3400	848	1.33	2950	798	1.01	2474	754	0.75	---	---	---	---	---	---
0.9	3303	890	1.41	2871	848	1.11	2408	804	0.82	---	---	---	---	---	---	---	---	---
1.1	2838	897	1.23	---	---	---	---	---	---	---	---	---	---	---	---	---	---	---

HIGH-STATIC BELT DRIVE — DOWN SHOT

ESP IN H ₂ O	TURNS OPEN																	
	0			1			2			3			4			5		
	CFM	RPM	BHP	CFM	RPM	BHP	CFM	RPM	BHP	CFM	RPM	BHP	CFM	RPM	BHP	CFM	RPM	BHP
0.9	---	---	---	---	---	---	---	---	---	---	---	---	---	---	---	3401	909	1.51
1.1	---	---	---	---	---	---	---	---	---	---	---	---	3428	965	1.71	2943	915	1.3
1.3	---	---	---	---	---	---	---	---	---	3471	1015	1.9	3012	971	1.5	2423	920	1.12
1.5	---	---	---	---	---	---	3722	1063	2.25	3041	1023	1.67	2503	976	1.31	---	---	---
1.7	---	---	---	---	---	---	3359	1075	2.04	2540	1031	1.5	---	---	---	---	---	---
1.9	---	---	---	3381	1119	2.22	2890	1080	1.78	---	---	---	---	---	---	---	---	---
2.1	---	---	---	3089	1129	2.04	---	---	---	---	---	---	---	---	---	---	---	---

STANDARD BELT DRIVE & TWO-SPEED STANDARD BELT DRIVE AT HIGH SPEED — HORIZONTAL

ESP IN H ₂ O	TURNS OPEN																	
	0			1			2			3			4			5		
	CFM	RPM	BHP	CFM	RPM	BHP	CFM	RPM	BHP	CFM	RPM	BHP	CFM	RPM	BHP	CFM	RPM	BHP
0.1	---	---	---	---	---	---	---	---	---	---	---	---	3625	701	1.08	3309	660	0.86
0.3	---	---	---	---	---	---	3815	797	1.44	3468	747	1.11	3177	703	0.88	2796	663	0.68
0.5	---	---	---	3780	841	1.52	3405	803	1.23	3053	753	0.94	2608	709	0.68	2225	665	0.53
0.7	3687	885	1.6	3327	847	1.29	2968	805	1.02	2423	758	0.73	---	---	---	---	---	---
0.9	3236	891	1.39	2850	852	1.1	2352	807	0.8	---	---	---	---	---	---	---	---	---
1.1	2713	896	1.17	---	---	---	---	---	---	---	---	---	---	---	---	---	---	---

HIGH-STATIC BELT DRIVE — HORIZONTAL

ESP IN H ₂ O	TURNS OPEN																	
	0			1			2			3			4			5		
	CFM	RPM	BHP	CFM	RPM	BHP	CFM	RPM	BHP	CFM	RPM	BHP	CFM	RPM	BHP	CFM	RPM	BHP
0.9	---	---	---	---	---	---	---	---	---	---	---	---	---	---	---	3447	902	1.54
1.1	---	---	---	---	---	---	---	---	---	---	---	---	3398	956	1.65	3006	908	1.31
1.3	---	---	---	---	---	---	---	---	---	3486	1008	1.87	2960	962	1.44	---	---	---
1.5	---	---	---	---	---	---	3514	1057	2.07	2949	1019	1.62	---	---	---	---	---	---
1.7	---	---	---	3388	1103	2.18	3036	1069	1.84	---	---	---	---	---	---	---	---	---
1.9	---	---	---	2959	1114	2.0	---	---	---	---	---	---	---	---	---	---	---	---
2.1	---	---	---	2527	1124	1.86	---	---	---	---	---	---	---	---	---	---	---	---

NOTES

- Assume dry coil with filter in place; CFM correction for wet coil = 3%
- Any adjustment made to the blower should not cause the motor to draw more than the motor rated RLA. Applications that exceed the above
- could require a larger motor. Minimum rated SCFM is 350 per ton.

STANDARD BELT DRIVE & TWO-SPEED STANDARD BELT DRIVE AT HIGH SPEED — DOWN SHOT

ESP IN H ₂ O	TURNS OPEN																	
	0			1			2			3			4			5		
	CFM	RPM	BHP	CFM	RPM	BHP	CFM	RPM	BHP	CFM	RPM	BHP	CFM	RPM	BHP	CFM	RPM	BHP
0.1	---	---	---	---	---	---	---	---	---	---	---	---	3467	701	1.04	3143	650	0.81
0.3	---	---	---	---	---	---	---	---	---	3391	746	1.12	3029	701	0.85	2607	653	0.63
0.5	---	---	---	---	---	---	3297	795	1.20	2899	751	0.91	2456	707	0.68	---	---	---
0.7	---	---	---	3250	845	1.30	2800	795	0.98	---	---	---	---	---	---	---	---	---
0.9	3153	887	1.38	2721	845	1.08	---	---	---	---	---	---	---	---	---	---	---	---
1.1	2688	894	1.20	---	---	---	---	---	---	---	---	---	---	---	---	---	---	---

HIGH-STATIC BELT-DRIVE — DOWN SHOT

ESP IN H ₂ O	TURNS OPEN																	
	0			1			2			3			4			5		
	CFM	RPM	BHP	CFM	RPM	BHP	CFM	RPM	BHP	CFM	RPM	BHP	CFM	RPM	BHP	CFM	RPM	BHP
0.9	---	---	---	---	---	---	---	---	---	---	---	---	---	---	---	3251	906	1.48
1.1	---	---	---	---	---	---	---	---	---	---	---	---	3278	962	1.68	2793	912	1.27
1.3	---	---	---	---	---	---	---	---	---	3321	1012	1.87	2862	968	1.47	---	---	---
1.5	---	---	---	---	---	---	3572	1060	2.22	2891	1020	1.64	---	---	---	---	---	---
1.7	---	---	---	---	---	---	3209	1072	2.01	---	---	---	---	---	---	---	---	---
1.9	---	---	---	3231	1116	2.19	2740	1077	1.75	---	---	---	---	---	---	---	---	---
2.1	3256	1156	2.31	2939	1126	2.01	---	---	---	---	---	---	---	---	---	---	---	---

STANDARD BELT DRIVE & TWO-SPEED STANDARD BELT DRIVE AT HIGH SPEED — HORIZONTAL

ESP IN H ₂ O	TURNS OPEN																	
	0			1			2			3			4			5		
	CFM	RPM	BHP	CFM	RPM	BHP	CFM	RPM	BHP	CFM	RPM	BHP	CFM	RPM	BHP	CFM	RPM	BHP
0.1	---	---	---	---	---	---	---	---	---	---	---	---	3475	698	1.05	3159	657	0.83
0.3	---	---	---	---	---	---	3665	794	1.41	3318	744	1.08	3027	700	0.85	2646	660	0.65
0.5	---	---	---	3630	838	1.49	3255	800	1.2	2903	750	0.91	2458	706	0.65	---	---	---
0.7	3537	882	1.57	3177	844	1.26	2818	802	0.99	---	---	---	---	---	---	---	---	---
0.9	3086	888	1.36	2700	849	1.07	---	---	---	---	---	---	---	---	---	---	---	---
1.1	2563	893	1.14	---	---	---	---	---	---	---	---	---	---	---	---	---	---	---

HIGH-STATIC BELT-DRIVE — HORIZONTAL

ESP IN H ₂ O	TURNS OPEN																	
	0			1			2			3			4			5		
	CFM	RPM	BHP	CFM	RPM	BHP	CFM	RPM	BHP	CFM	RPM	BHP	CFM	RPM	BHP	CFM	RPM	BHP
0.9	---	---	---	---	---	---	---	---	---	---	---	---	---	---	---	3297	899	1.51
1.1	---	---	---	---	---	---	---	---	---	---	---	---	3248	953	1.62	2856	905	1.28
1.3	---	---	---	---	---	---	---	---	---	3336	1005	1.84	2810	959	1.41	---	---	---
1.5	---	---	---	---	---	---	3364	1054	2.04	2799	1016	1.59	---	---	---	---	---	---
1.7	---	---	---	3238	1100	2.15	2886	1066	1.81	---	---	---	---	---	---	---	---	---
1.9	3188	1146	2.23	2809	1111	1.97	---	---	---	---	---	---	---	---	---	---	---	---

NOTES

- Assume dry coil with filter in place; CFM correction for wet coil = 3%
- Any adjustment made to the blower should not cause the motor to draw more than the motor rated RLA. Applications that exceed the above
- could require a larger motor. Minimum rated SCFM is 350 per ton.

STANDARD BELT DRIVE & TWO-SPEED BELT DRIVE AT HIGH SPEED — DOWN SHOT

ESP IN H ₂ O	TURNS OPEN																	
	0			1			2			3			4			5		
	CFM	RPM	BHP	CFM	RPM	BHP	CFM	RPM	BHP	CFM	RPM	BHP	CFM	RPM	BHP	CFM	RPM	BHP
0.2	---	---	---	---	---	---	---	---	---	---	---	---	4629	774	1.76	4269	733	1.42
0.4	---	---	---	---	---	---	---	---	---	4539	824	1.86	4198	781	1.53	3797	735	1.21
0.6	---	---	---	---	---	---	4511	868	2.01	4103	829	1.63	3752	787	1.33	3312	745	1.03
0.8	---	---	---	4445	912	2.14	4144	873	1.81	3695	833	1.45	3180	790	1.07	---	---	---
1	4418	956	2.3	4073	917	1.92	3661	879	1.55	---	---	---	---	---	---	---	---	---
1.2	4064	967	2.09	3518	923	1.6	---	---	---	---	---	---	---	---	---	---	---	---
1.4	3555	972	1.77	---	---	---	---	---	---	---	---	---	---	---	---	---	---	---

HIGH-STATIC BELT DRIVE — DOWN SHOT

ESP IN H ₂ O	TURNS OPEN																	
	0			1			2			3			4			5		
	CFM	RPM	BHP	CFM	RPM	BHP	CFM	RPM	BHP	CFM	RPM	BHP	CFM	RPM	BHP	CFM	RPM	BHP
0.8	---	---	---	---	---	---	---	---	---	---	---	---	4681	937	2.38	4206	891	1.91
1	---	---	---	---	---	---	---	---	---	4634	985	2.57	4288	948	2.19	3721	897	1.63
1.2	---	---	---	---	---	---	4533	1020	2.63	4367	995	2.41	3845	954	1.91	---	---	---
1.4	---	---	---	4550	1064	2.83	4290	1042	2.56	3913	1006	2.13	---	---	---	---	---	---
1.6	---	---	---	4327	1087	2.73	3990	1057	2.37	---	---	---	---	---	---	---	---	---
1.8	4652	1148	3.33	4023	1105	2.58	---	---	---	---	---	---	---	---	---	---	---	---
2	4306	1162	3.05	---	---	---	---	---	---	---	---	---	---	---	---	---	---	---

STANDARD BELT DRIVE & TWO-SPEED BELT DRIVE AT HIGH SPEED — HORIZONTAL

ESP IN H ₂ O	TURNS OPEN																	
	0			1			2			3			4			5		
	CFM	RPM	BHP	CFM	RPM	BHP	CFM	RPM	BHP	CFM	RPM	BHP	CFM	RPM	BHP	CFM	RPM	BHP
0.2	---	---	---	---	---	---	---	---	---	---	---	---	---	---	---	4707	724	1.62
0.4	---	---	---	---	---	---	---	---	---	---	---	---	4679	774	1.78	4235	730	1.4
0.6	---	---	---	---	---	---	---	---	---	4595	822	1.91	4223	780	1.55	3679	735	1.16
0.8	---	---	---	---	---	---	4468	862	1.96	4121	824	1.64	3596	785	1.26	---	---	---
1	---	---	---	4349	907	2.06	3990	868	1.72	3463	829	1.31	---	---	---	---	---	---
1.2	4486	962	2.35	3923	918	1.84	3267	879	1.33	---	---	---	---	---	---	---	---	---
1.4	3990	967	2.03	---	---	---	---	---	---	---	---	---	---	---	---	---	---	---

HIGH-STATIC BELT DRIVE — HORIZONTAL

ESP IN H ₂ O	TURNS OPEN																	
	0			1			2			3			4			5		
	CFM	RPM	BHP	CFM	RPM	BHP	CFM	RPM	BHP	CFM	RPM	BHP	CFM	RPM	BHP	CFM	RPM	BHP
0.8	---	---	---	---	---	---	---	---	---	---	---	---	---	---	---	4604	886	2.15
1	---	---	---	---	---	---	---	---	---	---	---	---	4737	940	2.48	4236	890	1.93
1.2	---	---	---	---	---	---	---	---	---	4792	984	2.69	4347	946	2.19	3675	901	1.64
1.4	---	---	---	---	---	---	4431	998	2.46	4404	995	2.45	3710	956	1.82	---	---	---
1.6	---	---	---	4652	1061	2.93	4183	1028	2.42	3845	1006	2.08	---	---	---	---	---	---
1.8	---	---	---	4418	1083	2.81	3847	1050	2.22	---	---	---	---	---	---	---	---	---
2	4823	1149	3.5	4055	1105	2.6	---	---	---	---	---	---	---	---	---	---	---	---

STANDARD BELT DRIVE & TWO-SPEED BELT DRIVE AT HIGH SPEED — DOWN SHOT

ESP (IN W.C.)	TURNS OPEN											
	0		1		2		3		4		5	
	CFM	BHP	CFM	BHP	CFM	BHP	CFM	BHP	CFM	BHP	CFM	BHP
0.2	---	---	---	---	5378	2.35	4967	1.92	4710	1.59	4512	1.33
0.4	5514	2.92	5349	2.56	4750	1.97	4583	1.71	4319	1.40	4030	1.13
0.6	5204	2.69	4919	2.27	4488	1.81	4258	1.54	---	---	---	---
0.8	4830	2.42	4649	2.09	4019	1.55	---	---	---	---	---	---
1.0	4497	2.19	4264	1.86	---	---	---	---	---	---	---	---

HIGH-STATIC BELT DRIVE --- DOWN SHOT

ESP (IN W.C.)	TURNS OPEN											
	0		1		2		3		4		5	
	CFM	BHP	CFM	BHP	CFM	BHP	CFM	BHP	CFM	BHP	CFM	BHP
0.8	---	---	---	---	---	---	5978	3.87	5691	3.38	5324	2.81
1.0	---	---	---	---	5947	4.16	5656	3.58	5376	3.12	4933	2.52
1.2	---	---	---	---	5708	3.93	5459	3.40	4950	2.79	4441	2.18
1.4	5776	4.64	5510	4.07	5245	3.48	4844	2.88	4525	2.45	---	---
1.6	5465	4.30	5199	3.74	4894	3.17	4404	2.54	---	---	---	---
1.8	5145	3.97	4871	3.41	4495	2.83	---	---	---	---	---	---
2.0	4805	3.63	4565	3.13	4142	2.55	---	---	---	---	---	---
2.2	4429	3.27	4233	2.85	---	---	---	---	---	---	---	---

STANDARD BELT DRIVE & TWO-SPEED BELT DRIVE AT HIGH SPEED — HORIZONTAL

ESP (IN W.C.)	TURNS OPEN											
	0		1		2		3		4		5	
	CFM	BHP	CFM	BHP	CFM	BHP	CFM	BHP	CFM	BHP	CFM	BHP
0.2	---	---	---	---	---	---	5570	2.27	4935	1.70	4584	1.36
0.4	5871	3.20	5639	2.77	5307	2.31	4902	1.88	4637	1.55	4178	1.19
0.6	5610	3.00	5358	2.57	5051	2.15	4603	1.72	4341	1.41	---	---
0.8	5391	2.83	5010	2.33	4799	2.00	4393	1.61	---	---	---	---
1.0	5078	2.59	4676	2.11	4448	1.79	---	---	---	---	---	---
1.2	4521	2.20	4226	1.83	---	---	---	---	---	---	---	---

HIGH-STATIC BELT DRIVE --- HORIZONTAL

ESP (IN W.C.)	TURNS OPEN											
	0		1		2		3		4		5	
	CFM	BHP	CFM	BHP	CFM	BHP	CFM	BHP	CFM	BHP	CFM	BHP
0.8	---	---	---	---	---	---	---	---	5858	3.51	5538	2.97
1.0	---	---	---	---	---	---	5894	3.85	5502	3.20	5282	2.78
1.2	---	---	---	---	5780	4.04	5570	3.55	5110	2.88	4869	2.47
1.4	---	---	5900	4.49	5501	3.77	5312	3.33	4793	2.64	4598	2.28
1.6	5860	4.76	5514	4.08	5257	3.54	4945	3.01	4382	2.34	---	---
1.8	5615	4.49	5315	3.88	5020	3.32	4504	2.66	---	---	---	---
2.0	5529	4.40	4906	3.49	4601	2.96	---	---	---	---	---	---
2.2	4938	3.78	4541	3.15	4222	2.65	---	---	---	---	---	---

NOTES

- Assume dry coil with filter in place; CFM correction for wet coil = 3%
- Any adjustment made to the blower should not cause the motor to draw more than the motor rated RLA. Application that exceed the above could require a larger motor. Minimum rated SCFM is 350 per ton.

MODEL AND HEAT KIT USAGE	MCA ¹ AT 208 / 240V	MOP ² (AMPS) AT 208 / 240V	ACTUAL kW AT 240V	RECOMMENDED AIRFLOW RANGE
DCH090***3B/V***	40	50		
EHK3-16	74 / 85	80 / 90	15	3000-3375 CFM
EHK3-30	113 / 130	120 / 150	30	3000-3375 CFM
EHK3-45	147 / 169	150 / 175	43	3000-3375 CFM

MODEL AND HEAT KIT USAGE	MCA ¹ AT 480V	MOP ² (AMPS) AT 480V	ACTUAL kW AT 480V	RECOMMENDED AIRFLOW RANGE
DCH090***4B/V***	19	25		
EHK4-16	42	45	15	3000-3375 CFM
EHK4-30	64	70	30	3000-3375 CFM
EHK4-45	84	90	43	3000-3375 CFM

MODEL AND HEAT KIT USAGE	MCA ¹ AT 575V	MOP ² (AMPS) AT 575V	ACTUAL kW AT 575V	RECOMMENDED AIRFLOW RANGE
DCH090***7B/V***	14	15		
EHK4-16	32	35	15	---
EHK4-30	51	60	30	---
EHK4-45	68	70	43	---

¹ Minimum Circuit Ampacity

² Maximum Overcurrent Protection device

kW CORRECTION FACTOR

kW CORRECTION FACTOR FOR 1- & 3-PHASE UNITS					
SUPPLY VOLTAGE	240	230	220	210	208
CORRECTION FACTOR	1	0.93	0.82	0.78	0.76

kW CORRECTION FACTOR FOR 480V UNITS			
SUPPLY VOLTAGE	460	440	430
CORRECTION FACTOR	0.92	0.84	0.8

For other voltage, use $\text{voltage}^2 / 480^2$

kW CORRECTION FACTOR FOR 575V UNITS			
SUPPLY VOLTAGE	560	550	540
CORRECTION FACTOR	0.95	0.91	0.88

Multiply rated kW by correction factor to get actual kW.

MINIMUM AIRFLOW FOR ELECTRIC HEAT

HEATER SIZE (kW)	MINIMUM CFM
15	3,000
30	3,000
43	3,000

MODEL AND HEAT KIT USAGE	MCA ¹ AT 208 / 240V	MOP ² (AMPS) AT 208 / 240V	ACTUAL kW AT 240V	RECOMMENDED AIRFLOW RANGE (DOWNSHOT)	RECOMMENDED AIRFLOW RANGE (HORIZONTAL)
DCH102***3B/V***	43	50			
EHK3-16	88	90	15	3400 - 3825 CFM	3400 - 3825 CFM
EHK3-30	133	150	35	3400 - 3825 CFM	3400 - 3825 CFM
EHK3-45	173	175	43	3400 - 3825 CFM	3400 - 3825 CFM

MODEL AND HEAT KIT USAGE	MCA ¹ AT 480V	MOP ² (AMPS) AT 480V	ACTUAL kW AT 480V	RECOMMENDED AIRFLOW RANGE (DOWNSHOT)	RECOMMENDED AIRFLOW RANGE (HORIZONTAL)
DCH102***4B/V***	20	25			
EHK4-16	42	45	15	3400 - 3825 CFM	3400 - 3825 CFM
EHK4-30	65	70	30	3400 - 3825 CFM	3400 - 3825 CFM
EHK4-45	84	90	43	3400 - 3825 CFM	3400 - 3825 CFM

MODEL AND HEAT KIT USAGE	MCA ¹ AT 575V	MOP ² (AMPS) AT 575V	ACTUAL kW AT 575V	RECOMMENDED AIRFLOW RANGE (DOWNSHOT)	RECOMMENDED AIRFLOW RANGE (HORIZONTAL)
DCH102***7B/V***	17	20			
EHK7-16	36	40	15	3400 - 3825 CFM	3400 - 3825 CFM
EHK7-30	55	60	30	3400 - 3825 CFM	3400 - 3825 CFM
EHK7-45	71	80	43	3400 - 3825 CFM	3400 - 3825 CFM

¹ Minimum Circuit Ampacity

² Maximum Overcurrent Protection device

^ - EHK Heater Kits above require a three-phase power supply

kW CORRECTION FACTOR

kW CORRECTION FACTOR FOR 1- & 3-PHASE UNITS					
SUPPLY VOLTAGE	240	230	220	210	208
CORRECTION FACTOR	1	0.93	0.82	0.78	0.76

kW CORRECTION FACTOR FOR 480V UNITS			
SUPPLY VOLTAGE	460	440	430
CORRECTION FACTOR	0.92	0.84	0.8

For other voltage, use $\text{voltage}^2 / 480^2$

kW CORRECTION FACTOR FOR 575V UNITS			
SUPPLY VOLTAGE	560	550	540
CORRECTION FACTOR	0.95	0.91	0.88

Multiply rated kW by correction factor to get actual kW.

MINIMUM AIRFLOW FOR ELECTRIC HEAT

HEATER SIZE (kW)	MIN. CFM DOWNSHOT	MIN. CFM HORIZONTAL
15	3,400	3,400
30	3,400	3,400
43	3,400	3,400

MODEL AND HEAT KIT USAGE	MCA ¹ AT 208 / 240V	MOP ² (AMPS) AT 208 / 240V	ACTUAL kW AT 240V	RECOMMENDED AIRFLOW RANGE
DCH120***3B/V***	49	60		
EHK3-16	81 / 94	90 / 100	15	3500 - 4500 CFM
EHK3-30	122 / 139	125 / 150	35	3500 - 4500 CFM
EHK3-45	154 / 178	175 / 200	43	4000 - 4500 CFM

MODEL AND HEAT KIT USAGE	MCA ¹ AT 480V	MOP ² (AMPS) AT 480V	ACTUAL kW AT 480V	RECOMMENDED AIRFLOW RANGE
DCH120***4B/V***	24	30		
EHK4-16	46	50	15	3500 - 4500 CFM
EHK4-30	69	70	30	3500 - 4500 CFM
EHK4-45	89	90	43	4000 - 4500 CFM

MODEL AND HEAT KIT USAGE	MCA ¹ AT 575V	MOP ² (AMPS) AT 575V	ACTUAL kW AT 575V	RECOMMENDED AIRFLOW RANGE
DCH0120***7B/V***	17	20		
EHK7-16	36	40	15	3500 - 4500 CFM
EHK7-30	55	60	30	3500 - 4500 CFM
EHK7-45	71	80	43	4000 - 4500 CFM

¹ Minimum Circuit Ampacity

² Maximum Overcurrent Protection device

kW CORRECTION FACTOR

kW CORRECTION FACTOR FOR 1- & 3-PHASE UNITS					
SUPPLY VOLTAGE	240	230	220	210	208
CORRECTION FACTOR	1	0.93	0.82	0.78	0.76

kW CORRECTION FACTOR FOR 480V UNITS			
SUPPLY VOLTAGE	460	440	430
CORRECTION FACTOR	0.92	0.84	0.8

For other voltage, use $\text{voltage}^2 / 480^2$

kW CORRECTION FACTOR FOR 575V UNITS			
SUPPLY VOLTAGE	560	550	540
CORRECTION FACTOR	0.95	0.91	0.88

Multiply rated kW by correction factor to get actual kW.

MINIMUM AIRFLOW FOR ELECTRIC HEAT

HEATER SIZE (kW)	MIN. CFM DOWNSHOT	MIN. CFM HORIZONTAL
15	4,000	4,000
30	4,000	4,000
43	4,000	4,000

MODEL AND HEAT KIT USAGE	MCA ¹ AT 208 / 240V	MOP ² (AMPS) AT 208 / 240V	ACTUAL kW AT 240V	RECOMMENDED AIRFLOW RANGE
DCH150***3B/V***	65	80		
EHK3-16	110	110	15	4000 - 5600
EHK3-30	155	175	30	4300 - 5600
EHK3-45	194	200	43	4500 - 5600

MODEL AND HEAT KIT USAGE	MCA ¹ AT 480V	MOP ² (AMPS) AT 480V	ACTUAL kW AT 480V	RECOMMENDED AIRFLOW RANGE
DCH150***4B/V***	31	40		
EHK4-16	54	60	15	4000 - 5600
EHK4-30	76	80	30	4300 - 5600
EHK4-45	96	100	43	4500 - 5600

MODEL AND HEAT KIT USAGE	MCA ¹ AT 575V	MOP ² (AMPS) AT 575V	ACTUAL kW AT 575V	RECOMMENDED AIRFLOW RANGE
DCH150***7B/V***	23	30		
EHK7-16	42	45	15	4000 - 5600
EHK7-30	61	70	30	4300 - 5600
EHK7-45	77	80	43	4500 - 5600

¹ Minimum Circuit Ampacity (standard drive)

² Maximum Overcurrent Protection device (standard drive)

kW CORRECTION FACTOR

kW CORRECTION FACTOR FOR 1- & 3-PHASE UNITS					
SUPPLY VOLTAGE	240	230	220	210	208
CORRECTION FACTOR	1	0.93	0.82	0.78	0.76

kW CORRECTION FACTOR FOR 480V UNITS			
SUPPLY VOLTAGE	460	440	430
CORRECTION FACTOR	0.92	0.84	0.8

For other voltage, use $\text{voltage}^2 / 480^2$

kW CORRECTION FACTOR FOR 575V UNITS			
SUPPLY VOLTAGE	560	550	540
CORRECTION FACTOR	0.95	0.91	0.88

Multiply rated kW by correction factor to get actual kW.

MODEL TONNAGE	"A"	"B"
7.5 TON COMMERCIAL GAS, HT PUMP, AIR CONDITIONER	53.339	20.055
8.5 TON COMMERCIAL GAS, HT PUMP, AIR CONDITIONER	53.339	20.055
10 TON COMMERCIAL GAS, HT PUMP, AIR CONDITIONER	53.339	20.055
12.5 TON COMMERCIAL GAS, HT PUMP, AIR CONDITIONER	58.839	18.055

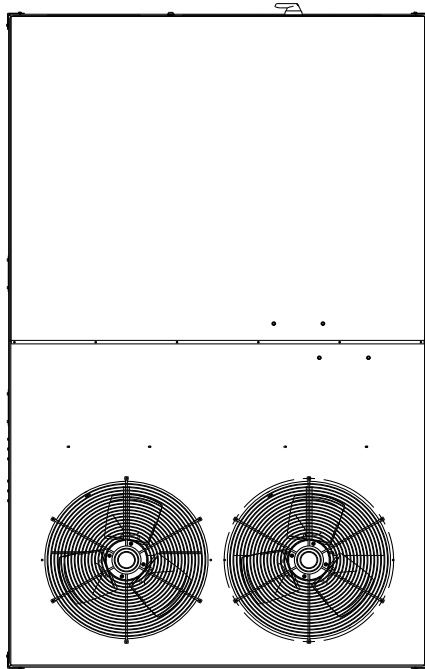

TOP VIEW

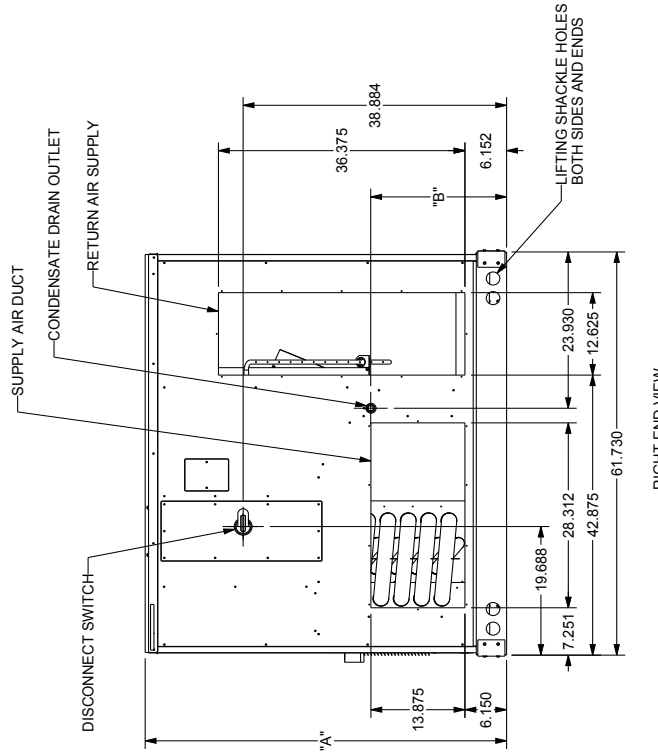

RIGHT END VIEW

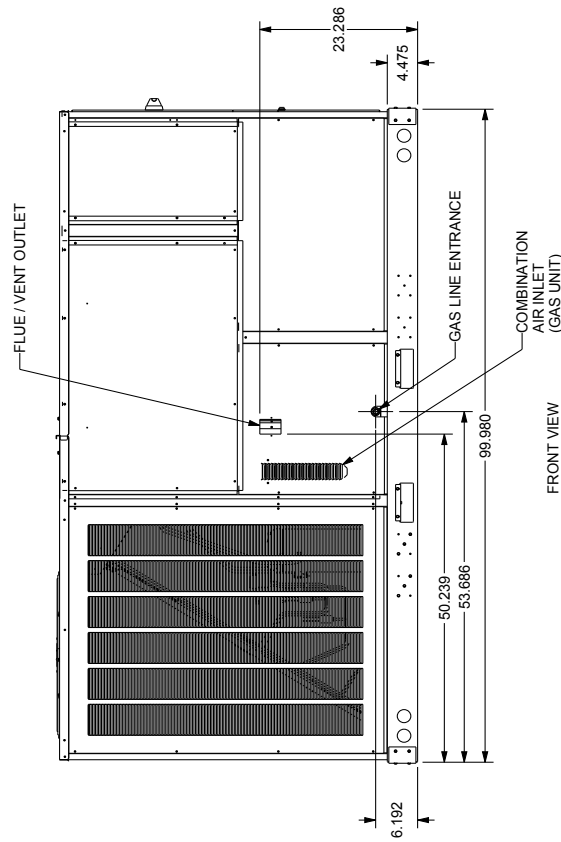

FRONT VIEW

DC*090-150***

7.5 THRU 12.5 TON COMMERCIAL

ALL DIMENSIONS GIVEN ARE IN INCHES
ALL DIMENSIONS AND SPECIFICATIONS ARE SUBJECT TO CHANGE WITHOUT NOTICE

Maintain an adequate clearance around the unit for safety, service, maintenance, and proper unit operation. Leave a total clearance of 75" on the main control panel side of the unit for possible removal of fan shaft, coil, electric heat, and gas furnace. Leave a clearance of 48" on all other sides of the unit for possible compressor removal or service access, and to ensure proper ventilation and condenser airflow. Do not install the unit beneath any obstruction. Install the unit away from all building exhausts to inhibit ingestion of exhaust air into the unit's fresh-air intake.

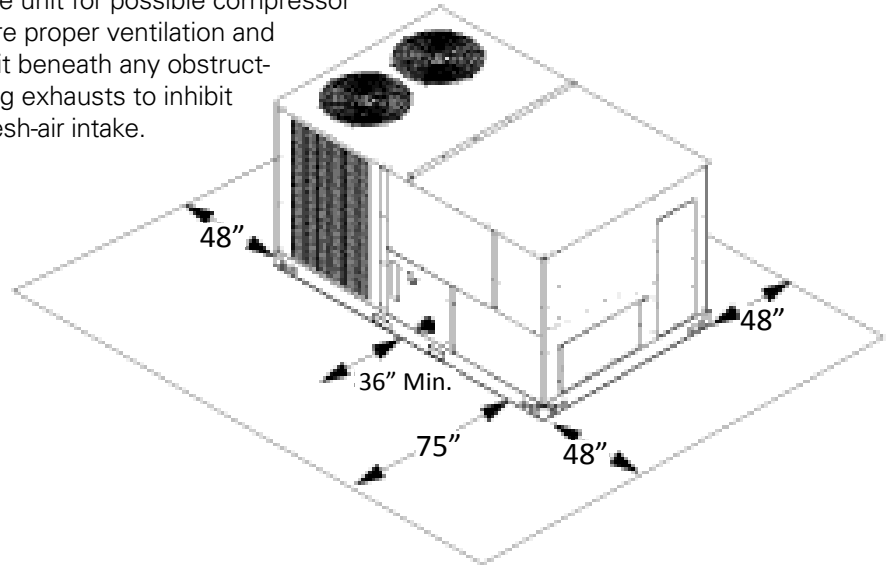

ELECTRICAL ENTRANCE LOCATIONS

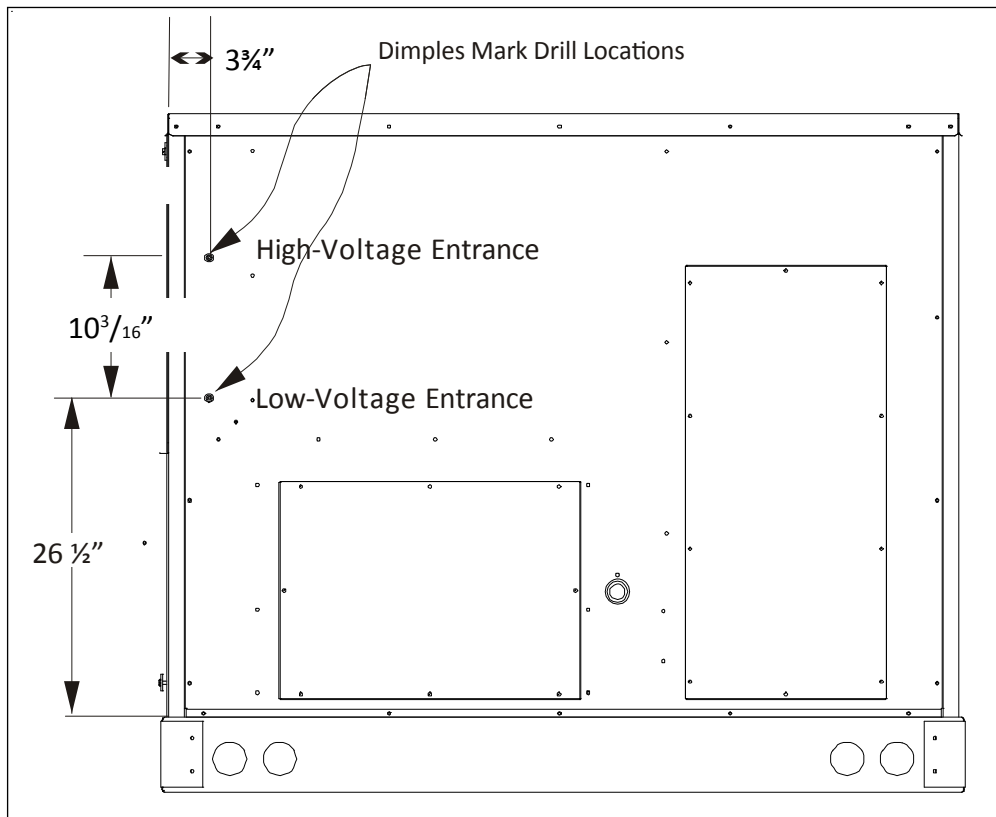

Provisions for forks have been included in the unit base frame. No other fork locations are approved.

- Unit must be lifted by the four lifting holes located at the base frame corners.
- Lifting cables should be attached to the unit with shackles.
- The distance between the crane hook and the top of the unit must not be less than 60”.
- Two spreader bars must span over the unit to prevent damage to the cabinet by the lift cables. Spreader bars must be of sufficient length so that cables do not come in contact with the unit during transport. Remove wood struts mounted beneath unit base frame before setting unit on roof curb. These struts are intended to protect unit base frame from fork lift damage. To remove the struts, extract the sheet metal retainers and pull the struts through the base of the unit. Refer to rigging label on the unit.

Important: If using bottom discharge with roof curb, duct-work should be attached to the curb prior to installing the unit. Duct-work dimensions are shown in Roof Curb Installation Instructions Manual.

Refer to the Roof Curb Installation Instructions for proper curb installation. Curbing must be installed in compliance with the National Roofing Contractors Association Manual.

Lower unit carefully onto roof mounting curb. While rigging the unit, the center of gravity will cause the condenser end to be lower than the supply air end.

Bring condenser end of unit into alignment with the curb. With condenser end of the unit resting on curb member and using curb as a fulcrum, lower opposite end of the unit until entire unit is seated on the curb. When a rectangular cantilever curb is used, take care to center the unit. Check for proper alignment and orientation of supply and return openings with duct.

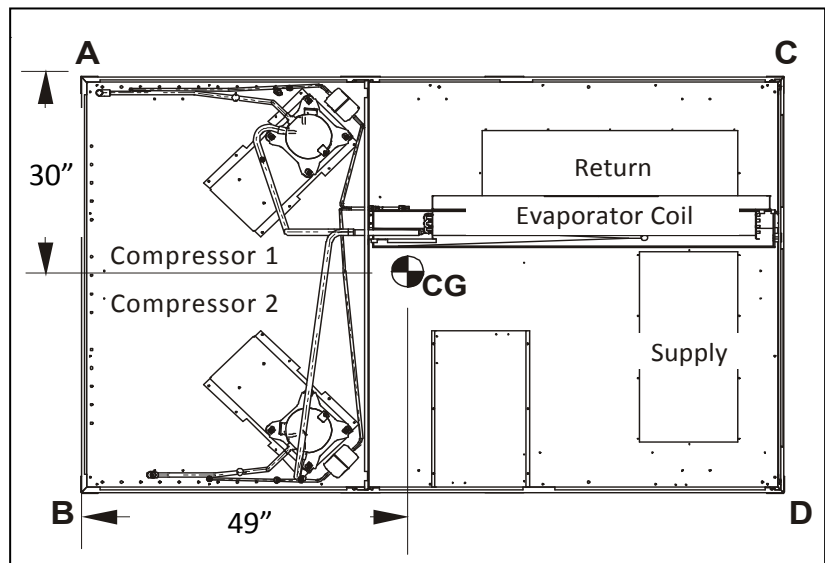
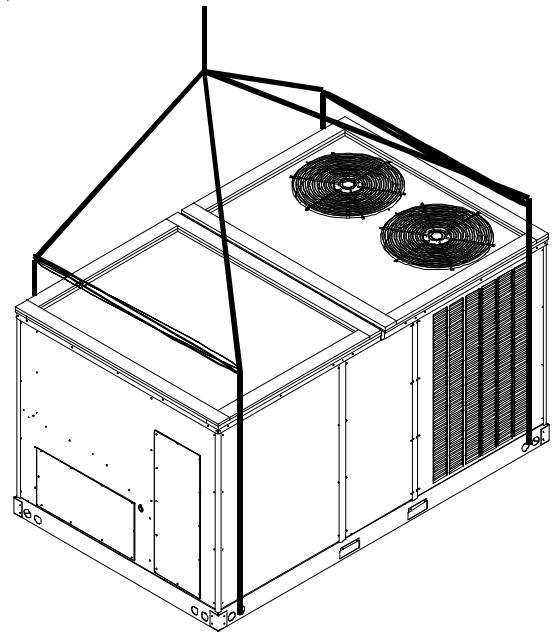

CORNER & CENTER-OF-GRAVITY LOCATIONS

UNIT WEIGHTS	7½-TON WEIGHTS (LBS)	8½-TON WEIGHTS (LBS)	10-TON WEIGHTS (LBS)	12½-TON WEIGHTS (LBS)
Weight A	285	345	345	435
Weight B	285	325	325	345
Weight C	285	320	320	300
Weight D	285	300	300	240
Shipping Weight	1175	1310	1310	1350
Operating Weight	1135	1285	1285	1325

Note: These weights are calculated without accessories installed.

Curb installations must comply with local codes and should follow the established guidelines of the National Roofing Contractors Association.

Proper unit installation requires that the roof curb be firmly and permanently attached to the roof structure. Check for adequate fastening method prior to setting the unit on the curb.

Full perimeter roof curbs are available from the factory and are shipped unassembled. The installing contractor is responsible for field assembly, squaring, leveling, and mounting on the roof structure. All required hardware necessary for the assembly of the sheet metal curb is included in the curb accessory package.

- Determine sufficient structural support before locating and mounting the curb and package unit.
- Duct-work must be constructed using industry guidelines. The duct-work must be placed into the roof curb before mounting the package unit. Our full perimeter curbs include duct connection frames to be assembled with the curb. Cantilevered-type curbs are not available from the factory.
- Contractor furnishes curb insulation, cant strips, flashing, and general roofing material.
- Support curbs on parallel sides with roof members. To prevent damage to the unit, the roof members cannot penetrate supply and return duct openings.

Note: The unit and curb accessories are designed to allow vertical duct installation before unit placement. Duct installation after unit placement is not recommended.

3-D VIEW

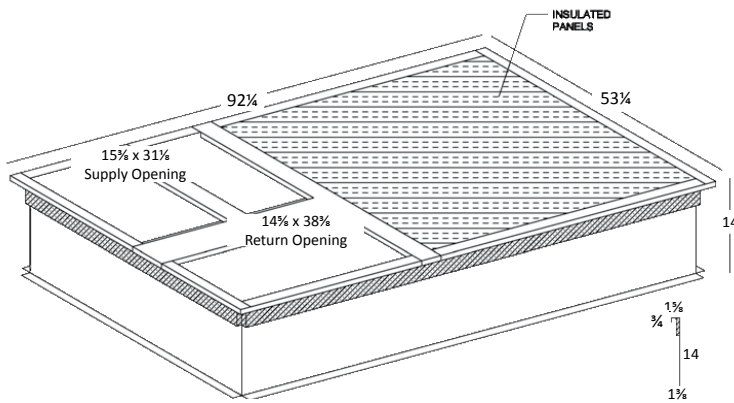

See the manual shipped with the roof curb for assembly and installation instructions.

TOP VIEW

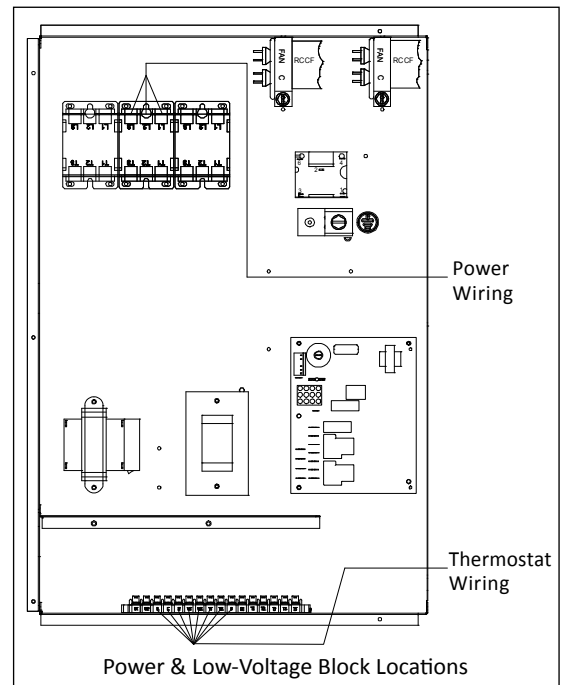
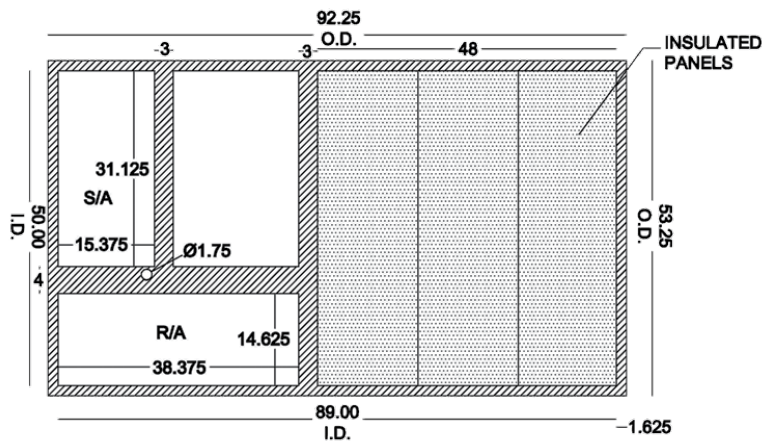

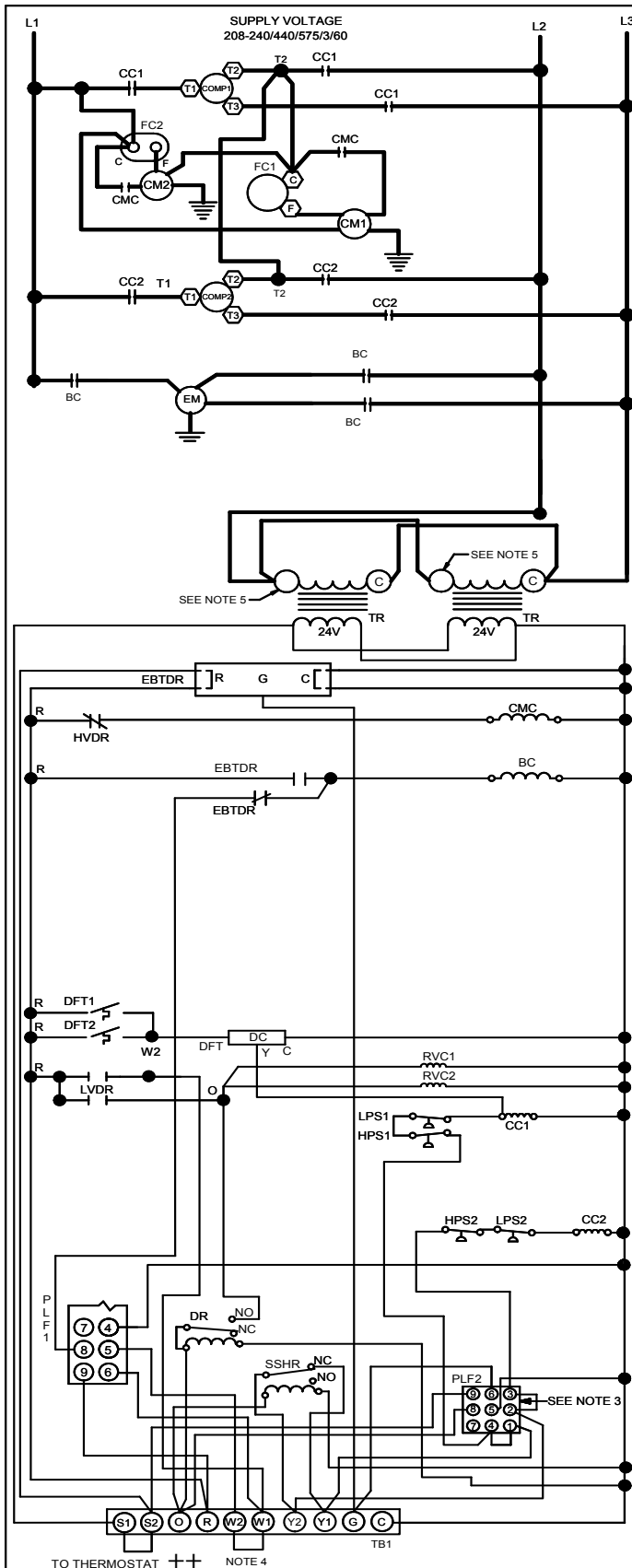

COMPONENT LEGEND

BC	BLOWER CONTACTOR
BR	BLOWER RELAY
CB	CIRCUIT BREAKER
CCR	COMPRESSOR CONTACTOR RELAY
CC	COMPRESSOR CONTACTOR
CM	CONDENSER MOTOR
CMC	CONDENSER MOTOR CONTACTOR
COMP	COMPRESSOR
DC	DEFROST CONTROL
DFT	DEFROST THERMOSTAT
ECON	ECONOMIZER
EBTD	ELECTRONIC BLOWER TIME DELAY
EMR	EVAPORATOR MOTOR RELAY
R	RELAY
EM	EVAPORATOR MOTOR
FC	FAN CAPACITOR
GND	EQUIPMENT GROUND
HPS	HIGH PRESSURE SWITCH
HVDR	HIGH VOLTAGE DEFROST RELAY
LPS	LOW PRESSURE SWITCH
LVDR	LOW VOLTAGE DEFROST RELAY
LVJB	LOW VOLTAGE JUNCTION BOX
PB	POWER DISTRIBUTION BLOCK
PLF	FEMALE PLUG / CONNECTOR
RVC	REVERSING VALVE COIL
TB1	TERMINAL BLOCK (24V SIGNAL)
TR	TRANSFORMER
SSHR	SECOND STAGE HEATER RELAY

FACILITY WIRING

—	LINE VOLTAGE
—	LOW VOLTAGE
---	OPTIONAL
---	HIGH VOLTAGE

FIELD WIRING

—	HIGH VOLTAGE
---	LOW VOLTAGE

WIRE CODE

BK	BLACK
BL	BLUE
BR	BROWN
GR	GREEN
OR	ORANGE
PK	PINK
PU	PURPLE
RD	RED
WH	WHITE
YL	YELLOW
YL/PK	YELLOW WITH PINK STRIP
BL/PK	BLUE WITH PINK STRIP

NOTES:

- REPLACEMENT WIRE MUST BE SAME SIZE AND TYPE INSULATION AS ORIGINAL (AT LEAST 105°C) USE COPPER CONDUCTOR ONLY.
- USE COPPER CONDUCTORS ONLY
++ USE N.E.C. CLASS 2 WIRE
- ECONOMIZER PLUG LOCATED IN THE RETURN AIR COMPARTMENT. REMOVE MALE PLUG AND ATTACH FEMALE PLUG TO THE ECONOMIZER ACCESSORY.
- FOR TWO STAGE OPERATION REMOVE W1 TO W2 JUMPER WIRE.
- MOVE WIRE(S) TO APPROPRIATE INPUT VOLTAGE TERMINAL ON TRANSFORMER.

THERMOSTAT FIELD WIRING ++

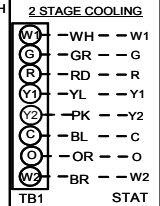

SEE UNIT RATING PLATE FOR TYPE AND SIZE OF OVER CURRENT PROTECTION



208-240/460/575/3/60 0140L02569-A

High Voltage: Disconnect all power before servicing or installing this unit. Multiple power sources may be present. Failure to do so may cause property damage, personal injury, or death.

WARNING

Wiring is subject to change. Always refer to the wiring diagram on the unit for the most up-to-date wiring.

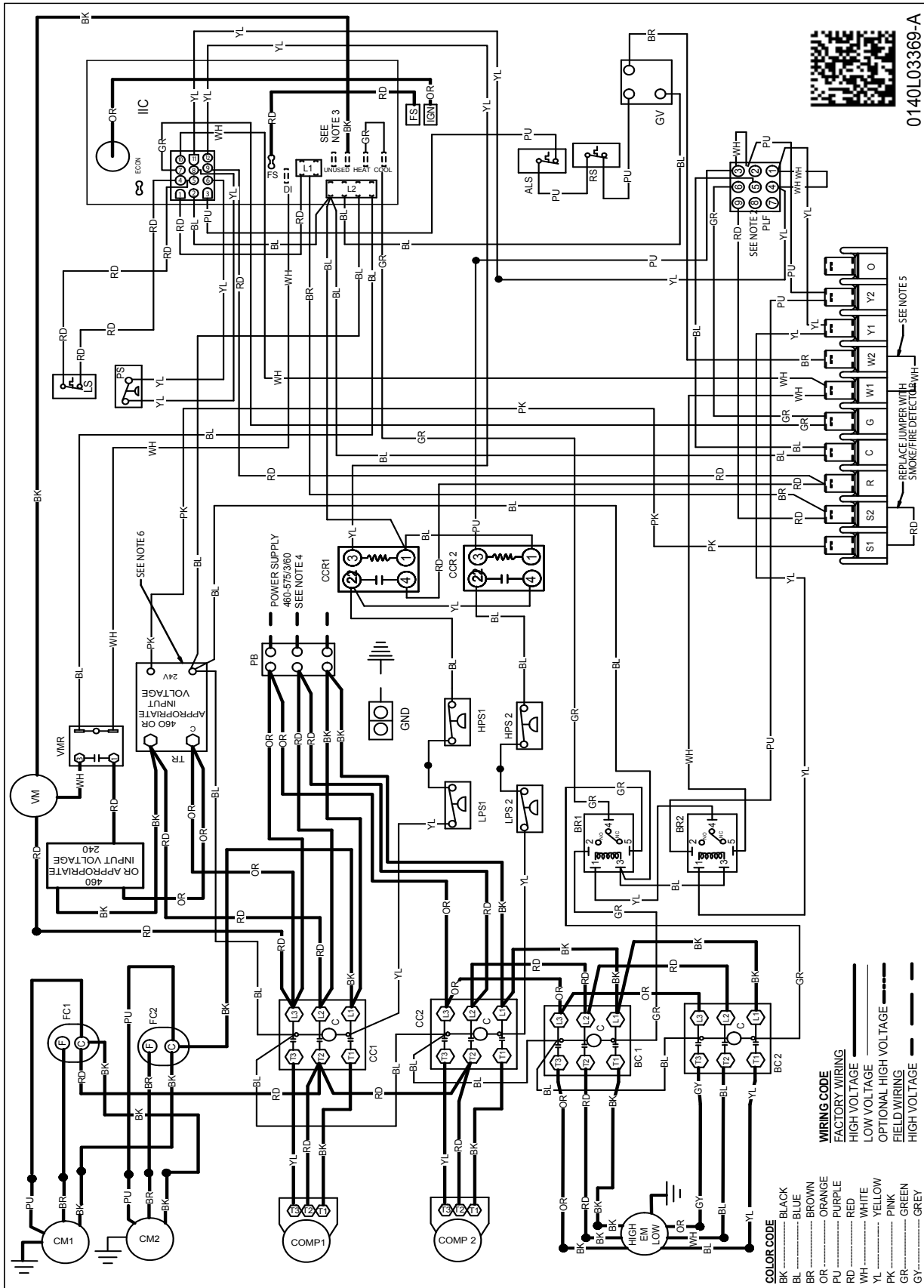

Wiring is subject to change. Always refer to the wiring diagram on the unit for the most up-to-date wiring.

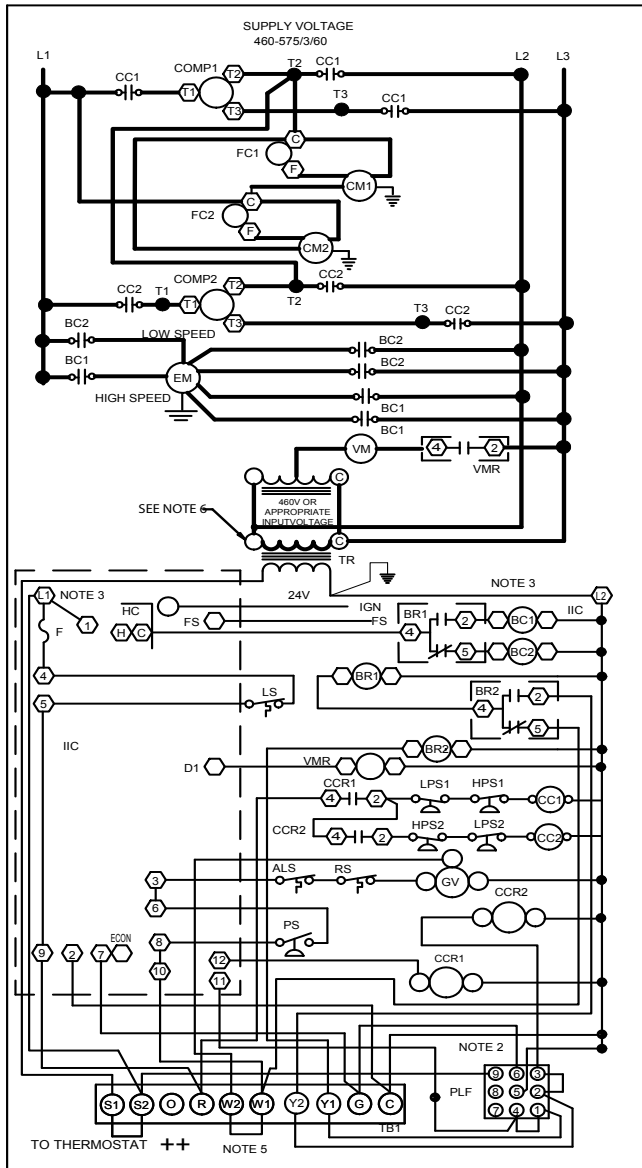

- COMPONENT LEGEND**
- ALS AUXILIARY LIMIT SWITCH
 - BC BLOWER CONTACTOR
 - BR BLOWER RELAY
 - CB CIRCUIT BREAKER
 - CC COMPRESSOR CONTACTOR
 - CCR COMPRESSOR CONTACTOR RELAY
 - CM COMPRESSOR MOTOR
 - COMP COMPRESSOR
 - EM EVAPORATOR MOTOR
 - F FUSE
 - FC FAN CAPACITOR
 - FS FLAME SENSOR
 - GND EQUIPMENT GROUND
 - GV GAS VALVE
 - HPS HIGH PRESSURE SWITCH
 - IBR INDOOR BLOWER RELAY
 - IIC INTEGRATED IGNITION CONTROL
 - IGN IGNITOR
 - LPS LOW PRESSURE SWITCH
 - LS LIMIT SWITCH
 - PLF FEMALE PLUG/CONNECTOR
 - PS PRESSURE SWITCH
 - RS ROLLOUT SWITCH
 - TB1 TERMINAL BLOCK (24V SIGNAL)
 - TR TRANSFORMER
 - VM VENT MOTOR
 - VMR VENT MOTOR RELAY

- FACTORY WIRING**
- LINE VOLTAGE
 - LOW VOLTAGE
- OPTIONAL HIGH VOLTAGE**
- HIGH VOLTAGE
 - LOW VOLTAGE
- FIELD WIRING**
- HIGH VOLTAGE
 - LOW VOLTAGE
- WIRE CODE**
- BK BLACK
 - BL BLUE
 - BR BROWN
 - GR GREEN
 - OR ORANGE
 - PK PINK
 - PU PURPLE
 - RD RED
 - WH WHITE
 - YL YELLOW
 - YL /PK YELLOW WITH PINK STRIP
 - BL /PK BLUE WITH PINK STRIP

- NOTES**
1. REPLACEMENT WIRE MUST BE THE SAME SIZE AND TYPE OF INSULATION AS ORIGINAL. (USE COPPER CONDUCTOR ONLY).
 2. ACCESSORY ECONOMIZER PLUG ADJACENT TO BLOWER HOUSING IN RETURN AIR COMPARTMENT. REMOVE MALE PLUG AND ATTACH FEMALE PLUG TO THE ECONOMIZER ACCESSORY.
 3. L1 AND L2 ON IIC CONTROL IS 24V INPUT.
 4. USE COPPER CONDUCTORS ONLY. ++ USE NEC CLASS 2 WIRE.
 5. FOR TWO STAGE OPERATION REMOVE W1 TO W2 JUMPER WIRE.
 6. MOVE WIRE(S) TO APPROPRIATE INPUT VOLTAGE TERMINAL ON TRANSFORMER.

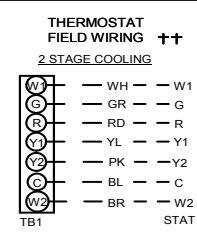

INSTALLER/SERVICEMAN

THE STATUS LIGHT ON THE FURNACE CONTROL MAY BE USED AS A GUIDE TO TROUBLESHOOTING THIS APPLIANCE. STATUS LIGHT CODES ARE AS FOLLOWS:

STATUS LIGHT	EQUIPMENT STATUS	CHECK
ON	NORMAL OPERATION	----
OFF	NO POWER OR INTERNAL CONTROL	CHECK INPUT POWER CHECK FUSE ON CONTROL REPLACE CONTROL
1 BLINK	IGNITION FAILURE	GAS FLOW GAS PRESSURE
	OPEN ROLLOUT SWITCH	GAS VALVE FLAME SENSOR
	OPEN AUX. LIMIT SWITCH	FLAME ROLLOUT BAD SWITCH AUX. LIMIT OPEN
2 BLINKS	PRESSURE SWITCH OPEN	CHECK PRESSURE SWITCH
3 BLINKS	PRESSURE SWITCH CLOSED WITHOUT INDUCER ON	CHECK PRESSURE SWITCH
4 BLINKS	OPEN LIMIT SWITCH	MAIN LIMIT OPEN BAD SWITCH
5 BLINKS	FALSE FLAME SENSED	STICKING GAS VALVE
6 BLINKS	COMPRESSOR OUTPUT DELAY	3 MIN. COMP. ANTI-CYCLE TIMER

SEE UNIT RATING PLATE FOR TYPE AND SIZE OF OVER CURRENT PROTECTION



460-575/3/60 0140L03370-A

High Voltage: Disconnect all power before servicing or installing this unit. Multiple power sources may be present. Failure to do so may cause property damage, personal injury, or death.

WARNING

Wiring is subject to change. Always refer to the wiring diagram on the unit for the most up-to-date wiring.

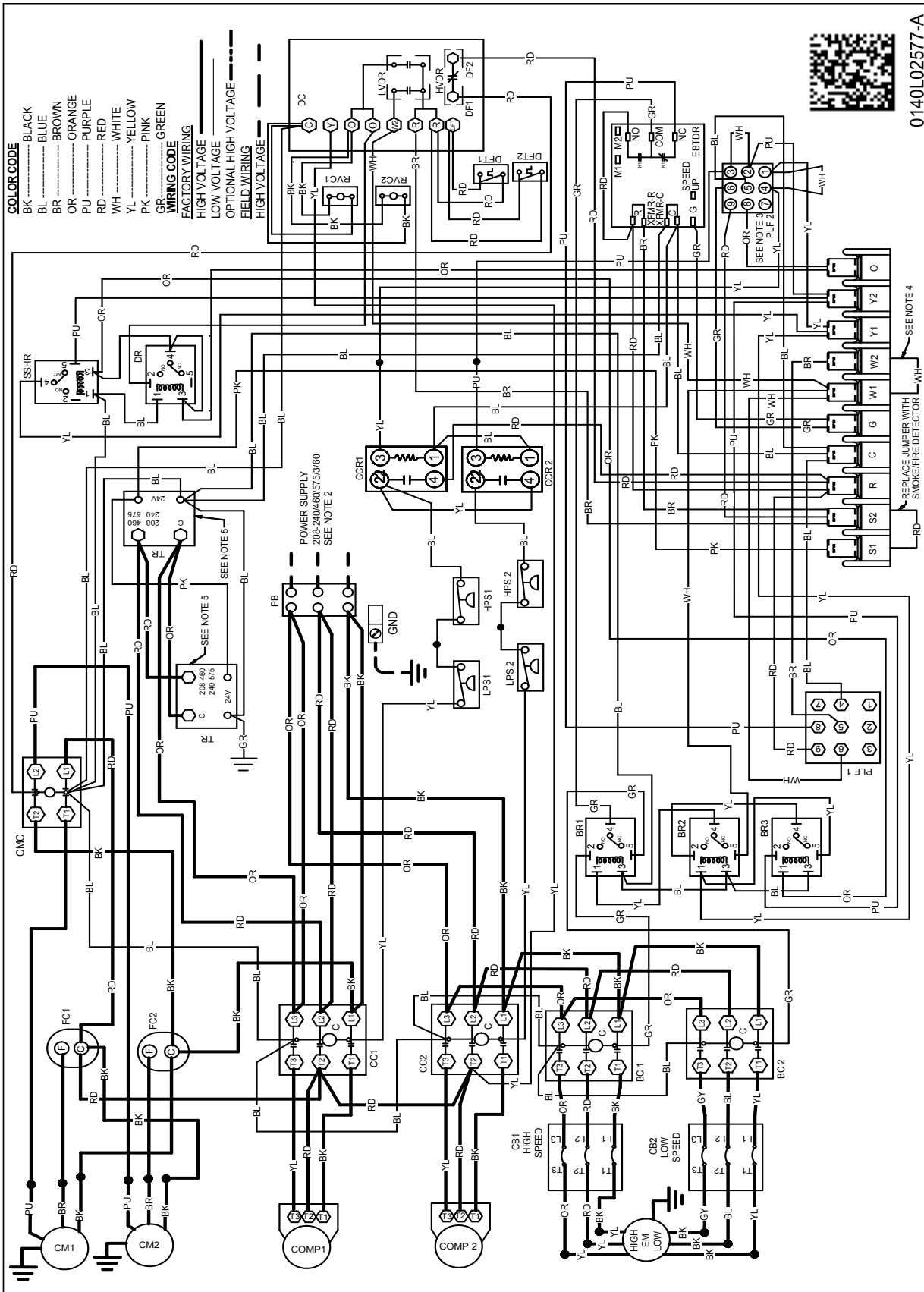

High Voltage: Disconnect all power before servicing or installing this unit. Multiple power sources may be present. Failure to do so may cause property damage, personal injury, or death.

WARNING

Wiring is subject to change. Always refer to the wiring diagram on the unit for the most up-to-date wiring.

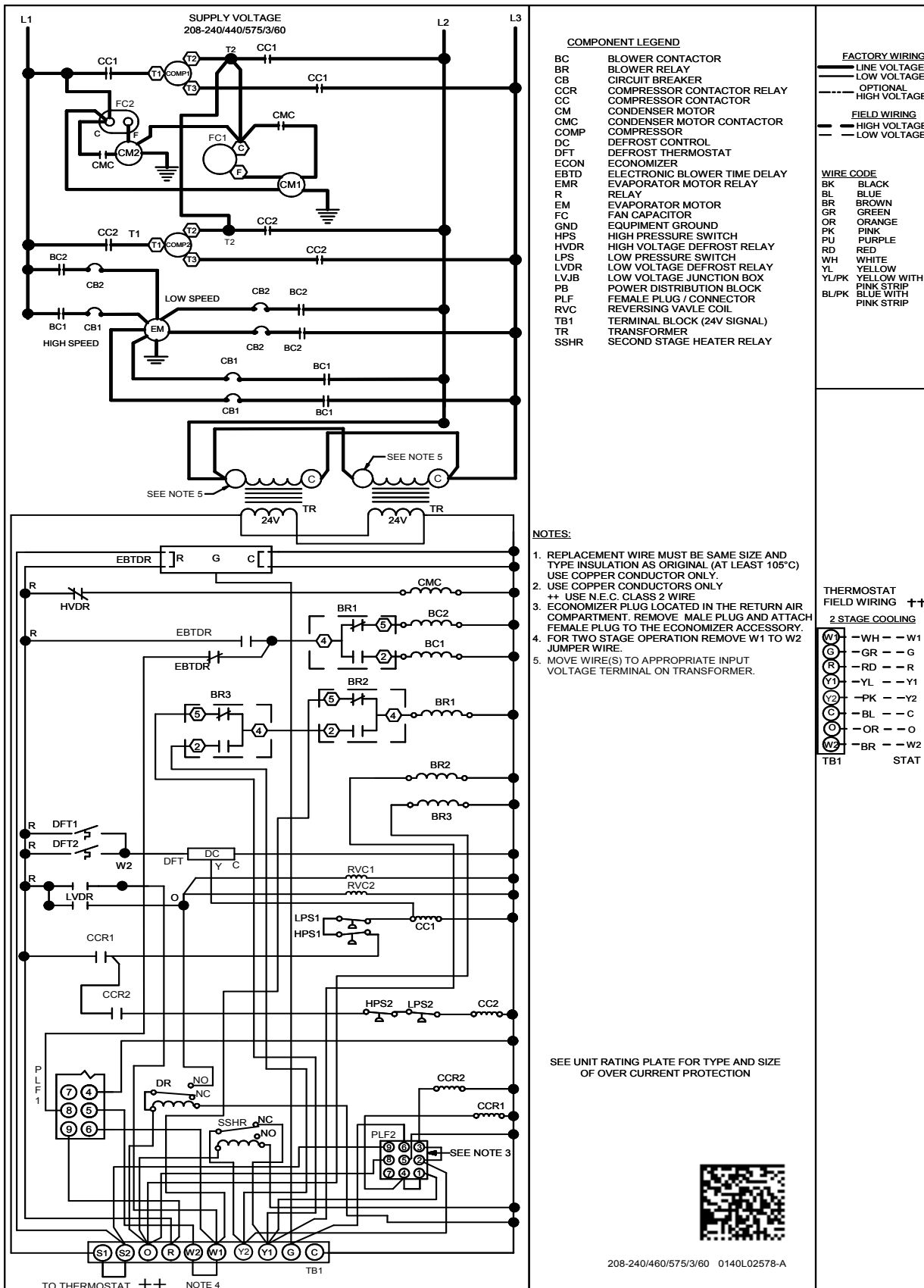

High Voltage: Disconnect all power before servicing or installing this unit. Multiple power sources may be present. Failure to do so may cause property damage, personal injury, or death.

WARNING

Wiring is subject to change. Always refer to the wiring diagram on the unit for the most up-to-date wiring.

FILED-INSTALLED ITEM #	DESCRIPTION	FITS MODEL SIZES	FIELD- INSTALLED	FACTORY- INSTALLED	OPERATING WEIGHT (LBS)
14CURB90150	14" Roof Curb	7½-12½ tons	√		143
D25FD90150	25% Manual Fresh Air Damper	7½-12½ tons	√		15
D25MFD90150	25% Motorized Fresh Air Damper	7½-12½ tons	√		21
DBRD3672	Barometric Relief Damper (2 required)	7½-12½ tons	√		30
DDNBBS90150	Burglar Bar Sleeves: includes Supply & Return	7½-12½ tons	√		45
CDK120	Concentric Duct Kit	10 tons	√		104
CDK150	Concentric Duct Kit	12½ tons	√		151
CDK90102	Concentric Duct Kit	7½-8½ tons	√		42
HailGD02D	Condenser Coil Hail Guard	7½-10 tons	√		34
HailGD05D	Condenser Coil Hail Guard	12½ tons	√		37
	Convenience Outlet: Powered	All Models		√	42
	Convenience Outlet: Non Powered	All Models		√	2
	Disconnect Switch (non-fused)	All Models		√	5
	Ultra Low-Leak Downflow Economizer ²	7½-12½ tons		√	137
DDNECNJ90150B	Low-Leak Downflow Economizer ³	7½-12½ tons	√	√	130
DDNSQRD9020	Downflow Square-to-Round Adapter 20" Round	7½ tons	√		55
	Electric Heat Kits	All Models	√	√	21
HSKT090G ¹	High-Static Kit (230/460v)	7½ tons	√		10
HSKT102 ¹	High-Static Kit (230/460v)	8½ tons	√		10
HSKT090G-7 ¹	High-Static Kit (575v)	7½ tons	√		10
HSKT102-7 ¹	High-Static Kit (575v)	8½ tons	√		10
HSKT120 ¹	High-Static Kit (230/460v)	10 tons	√		48
HSKT120-7 ¹	High-Static Kit (575v)	10 tons	√		48
HSKT150 ¹	High-Static Kit (230/460v)	12½ tons	√		80
HSKT150-7 ¹	High-Static Kit (575v)	12½ tons	√		80
DHZECNJ90150	Horizontal Economizer	7½-12½ tons	√		90
GHRC-1	Hurricane Restraint Clips	All Models	√		2
LAKT03	Low-Ambient Kit	7½ - 12½ tons	√	√	2
DPE901502	Downflow Power Exhaust (208/230v)	7½-12½ tons	√		65
DPE901504	Downflow Power Exhaust (460v)	7½-12½ tons	√		65
DPE901507	Downflow Power Exhaust (575v)	7½-12½ tons	√		65
	Smoke Detector	All Models		√	11
	Hinged Panels	7½-12½ tons		√	34

¹ HSKT High-Static Kits are for use with standard single-speed belt-drive units only.

² Please contact RRS Rooftop Systems directly if Power Exhaust is required.

³ Please use part number DPE901502 / DPE901504 / DPE901507 if Power Exhaust is required.

Note: Where multiple variations are available, the heaviest combination is listed.