

DCC SERIES

LIGHT COMMERCIAL PACKAGED HEATING AND COOLING UNIT

15 to 25 Ton

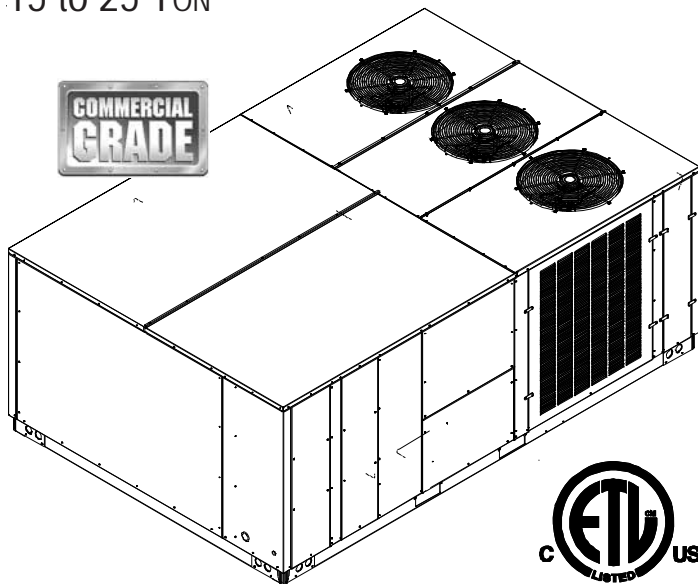

NOTE: 15 & 20 ton model shown in picture.
25 ton model has 2 fans.

ATTENTION INSTALLING PERSONNEL:
Prior to installation, thoroughly familiarize yourself with this Installation Manual. Observe all safety warnings. During installation or repair, caution is to be observed.

It is your responsibility to install the product safely and to educate the customer on its safe use.

 **RECOGNIZE THIS SYMBOL AS A SAFETY PRECAUTION.**

These installation instructions cover the **outdoor** installation of single package heating and cooling units. See the Specification Sheet applicable to your model for information regarding accessories.

***NOTE:** Please contact your distributor or our website for the applicable Specification Sheet referred to in this manual.

Index

Replacement Parts	2
Safety Instructions	2
General Information	2
Unit Location	3
Clearances	5
Roof Curb Post-Installation Checks	6
Roof Top Duct Connections	6
Rigging Details	6
Electrical Wiring	7
Circulating Air and Filters	9
Condensate Drain Connection	9
Startup, Adjustments, and Checks	10
Airflow Adjustments	11
Motor Sheave Adjustments	12
Maintenance	13
Appendix A Blower Performance Data	15
Belt Drive - Standard	15
Belt Drive - High Static	16
Appendix B Electrical Data	17
Appendix C Unit Dimensions	18
Appendix D Wiring Diagrams	19
Start-up Checklist	25

Our continuing commitment to quality products may mean a change in specifications without notice.



 **WARNING**

THIS PRODUCT CONTAINS OR PRODUCES A CHEMICAL OR CHEMICALS WHICH MAY CAUSE SERIOUS ILLNESS OR DEATH AND WHICH ARE KNOWN TO THE STATE OF CALIFORNIA TO CAUSE CANCER, BIRTH DEFECTS OR OTHER REPRODUCTIVE HARM.

 **WARNING**

TO AVOID PROPERTY DAMAGE, PERSONAL INJURY OR DEATH, DO NOT USE THIS UNIT IF ANY PART HAS BEEN UNDER WATER. IMMEDIATELY CALL A QUALIFIED SERVICE TECHNICIAN TO INSPECT THE FURNACE AND TO REPLACE ANY PART OF THE CONTROL SYSTEM AND ANY GAS CONTROL HAVING BEEN UNDER WATER.

REPLACEMENT PARTS

ORDERING PARTS

When reporting shortages or damages, or ordering repair parts, give the complete unit model and serial numbers as stamped on the unit's nameplate.

Replacement parts for this appliance are available through your contractor or local distributor. For the location of your nearest distributor, consult the white business pages, the yellow page section of the local telephone book or contact:

CONSUMER AFFAIRS
DAIKIN NORTH AMERICA LLC
7401 SECURITY WAY
HOUSTON, TEXAS 77040
855-770-5678

SAFETY INSTRUCTIONS

TO THE INSTALLER

Before installing this unit, please read this manual to familiarize yourself on the specific items which must be adhered to, including maximum external static pressure to unit, air temperature rise, minimum or maximum CFM and motor speed connections.

Keep this literature in a safe place for future reference.

 **CAUTION**

SHEET METAL PARTS, SCREWS, CLIPS AND SIMILAR ITEMS INHERENTLY HAVE SHARP EDGES, AND IT IS NECESSARY THAT THE INSTALLER AND SERVICE PERSONNEL EXERCISE CAUTION.

 **WARNING**

DO NOT CONNECT TO OR USE ANY DEVICE THAT IS NOT DESIGN CERTIFIED BY DAIKIN FOR USE WITH THIS UNIT. SERIOUS PROPERTY DAMAGE, PERSONAL INJURY, REDUCED UNIT PERFORMANCE AND/OR HAZARDOUS CONDITIONS MAY RESULT FROM THE USE OF SUCH NON-APPROVED DEVICES.

 **WARNING**

THIS UNIT MUST NOT BE USED AS A "CONSTRUCTION HEATER" DURING THE FINISHING PHASES OF CONSTRUCTION ON A NEW STRUCTURE. THIS TYPE OF USE MAY RESULT IN PREMATURE FAILURE OF THE UNIT DUE TO EXTREMELY LOW RETURN AIR TEMPERATURE AND EXPOSURE TO CORROSIVE OR VERY DIRTY ATMOSPHERES.

 **WARNING**

HIGH VOLTAGE!
DISCONNECT ALL POWER BEFORE SERVICING OR INSTALLING THIS UNIT. MULTIPLE POWER SOURCES MAY BE PRESENT. FAILURE TO DO SO MAY CAUSE PROPERTY DAMAGE, PERSONAL INJURY OR DEATH.



 **WARNING**

TO PREVENT THE RISK OF PROPERTY DAMAGE, PERSONAL INJURY, OR DEATH, DO NOT STORE COMBUSTIBLE MATERIALS OR USE GASOLINE OR OTHER FLAMMABLE LIQUIDS OR VAPORS IN THE VICINITY OF THIS APPLIANCE.

 **WARNING**

HIGH VOLTAGE!
INSTALLATION AND REPAIR OF THIS UNIT SHOULD BE PERFORMED **ONLY** BY INDIVIDUALS MEETING (AT A MINIMUM) THE REQUIREMENTS OF AN "ENTRY LEVEL TECHNICIAN" AS SPECIFIED BY THE AIR CONDITIONING, HEATING, AND REFRIGERATION INSTITUTE (AHRI).
ATTEMPTING TO INSTALL OR REPAIR THIS UNIT WITHOUT SUCH BACKGROUND MAY RESULT IN PRODUCT DAMAGE, PERSONAL INJURY OR DEATH.



GENERAL INFORMATION

 **WARNING**

TO PREVENT PROPERTY DAMAGE, PERSONAL INJURY OR DEATH, DUE TO FIRE, EXPLOSIONS, SMOKE, SOOT, CONDENSATION, ELECTRIC SHOCK OR CARBON MONOXIDE, THIS UNIT MUST BE PROPERLY INSTALLED, REPAIRED, OPERATED, AND MAINTAINED.

This unit is approved for outdoor installation ONLY. Rated performance is achieved after 72 hours of operation. Rated performance is delivered at the specified airflow. See outdoor unit specification sheet for split system models or product specification sheet for packaged and light commercial models. Specification sheets can be found at www.daikincomfort.com for Daikin brand products. Within the website, please select the residential or commercial products menu and then select the submenu for the type of product to be installed, such as air conditioners or heat pumps, to access a list of product pages that each contain links to that model's specification sheet.

To assure that your unit operates safely and efficiently, it must be installed, operated, and maintained in accordance with these installation and operating instructions, all local building codes and ordinances.

EPA REGULATIONS

IMPORTANT: THE UNITED STATES ENVIRONMENTAL PROTECTION AGENCY (EPA) HAS ISSUED VARIOUS REGULATIONS REGARDING THE INTRODUCTION AND DISPOSAL OF REFRIGERANTS IN THIS UNIT. FAILURE TO FOLLOW THESE REGULATIONS MAY HARM THE ENVIRONMENT AND CAN LEAD TO THE IMPOSITION OF SUBSTANTIAL FINES. BECAUSE REGULATIONS MAY VARY DUE TO PASSAGE OF NEW LAWS, WE SUGGEST A CERTIFIED TECHNICIAN PERFORM ANY WORK DONE ON THIS UNIT. SHOULD YOU HAVE ANY QUESTIONS PLEASE CONTACT THE LOCAL OFFICE OF THE EPA.

NATIONAL CODES

This product is designed and manufactured to permit installation in accordance with National Codes. It is the installer's responsibility to install the product in accordance with National Codes and/or prevailing local codes and regulations.

The heating and cooling capacities of the unit should be greater than or equal to the design heating and cooling loads of the area to be conditioned. The loads should be calculated by an approved method or in accordance with ASHRAE Guide or Manual J - Load Calculations published by the Air Conditioning Contractors of America.

Obtain from:

American National Standards Institute
1430 Broadway
New York, NY 10018

System design and installation should also, where applicable, follow information presented in accepted industry guides such as the ASHRAE Handbooks. The manufacturer assumes no responsibility for equipment installed in violation of any code or regulation. The mechanical installation of the packaged roof top units consists of making final connections between the unit and building services; supply and return duct connections; and drain connections (if required). The internal systems of the unit are completely factory-installed and tested prior to shipment.

Units are generally installed on a steel roof mounting curb assembly which has been shipped to the job site for installation on the roof structure prior to the arrival of the unit. The model number shown on the unit's identification plate identifies the various components of the unit such as refrigeration tonnage, heating input and voltage.

Carefully inspect the unit for damage. Any bolts or screws which may have loosened in transit must be re-tightened. In the event of damage, the receiver should:

1. Make notation on delivery receipt of any visible damage to shipment or container.
2. Notify carrier promptly and request an inspection.
3. In case of concealed damage, carrier should be notified as soon as possible-preferably within 5 days.
4. File the claim with the following supporting documents:
 - a. Original Bill of Lading, certified copy, or indemnity bond.
 - b. Original paid freight bill or indemnity in lieu thereof.
 - c. Original invoice or certified copy thereof, showing trade and other discounts or reductions.

- d. Copy of the inspection report issued by carrier representative at the time damage is reported to the carrier. The carrier is responsible for making prompt inspection of damage and for a thorough investigation of each claim. The distributor or manufacturer will not accept claims from dealers for transportation damage.

NOTE: When inspecting the unit for transportation damage, remove all packaging materials. Recycle or dispose of the packaging material according to local codes.

PRE-INSTALLATION CHECKS

Carefully read all instructions for the installation prior to installing unit. Ensure each step or procedure is understood and any special considerations are taken into account before starting installation. Assemble all tools, hardware and supplies needed to complete the installation. Some items may need to be purchased locally.

UNIT LOCATION



TO PREVENT POSSIBLE EQUIPMENT DAMAGE, PROPERTY DAMAGE, PERSONAL INJURY OR DEATH, THE FOLLOWING BULLET POINTS MUST BE OBSERVED WHEN INSTALLING THE UNIT.

IMPORTANT NOTE: Remove wood shipping rails prior to installation of the unit. *See important note under Roof Curb Installation Only.*

ALL INSTALLATIONS:

IMPORTANT NOTE: *Unit should be energized 24 hours prior to compressor start up to ensure crankcase heater has sufficiently warmed the compressors. Compressor damage may occur if this step is not followed.*

NOTE: Appliance is shipped from factory for vertical duct application.

Proper installation of the unit ensures trouble-free operation. Improper installation can result in problems ranging from noisy operation to property or equipment damages, dangerous conditions that could result in injury or personal property damage. Give this booklet to the user and explain its provisions. The user should retain these instructions for future reference.

- For proper operation and condensate drainage, the unit must be mounted level.
- The flue outlet hood must be at least three feet above any forced air inlet located within ten feet. The economizer/manual fresh air intake/motorized fresh air intake and combustion air inlet mounted on the unit are not affected by this restriction.
- Do not locate the unit in an area where the outdoor air

(i.e. combustion air for the unit) will be frequently contaminated by compounds containing chlorine or fluorine. Common sources of such compounds include swimming pool chemicals and chlorine bleaches, paint stripper, adhesives, paints, varnishes, sealers, waxes (which are not yet dried) and solvents used during construction and remodeling. Various commercial and industrial processes may also be sources of chlorine/fluorine compounds.

- To avoid possible illness or death of the building occupants, do NOT locate outside air intake device (economizer, manual fresh air intake, motorized fresh air intake) too close to an exhaust outlet, gas vent termination, or plumbing vent outlet. For specific distances required, consult local codes.
- Allow minimum clearances from the enclosure for fire protection, proper operation, and service access (see Unit Clearances). These clearances must be permanently maintained.
- When the unit is heating, the temperature of the return air entering the unit must be between 50°F and 100°F.

GROUND LEVEL INSTALLATIONS ONLY:

- When the unit is installed on the ground adjacent to the building, a level concrete (or equal) base is recommended. Prepare a base that is 3" larger than the package unit footprint and a minimum of 3" thick.
- The base should also be located where no runoff of water from higher ground can collect in the unit.

ROOF TOP INSTALLATIONS ONLY:

- To avoid possible property damage or personal injury, the roof must have sufficient structural strength to carry the weight of the unit(s) and snow or water loads as required by local codes. Consult a structural engineer to determine the weight capabilities of the roof.
- The unit may be installed directly on wood floors or on Class A, Class B, or Class C roof covering material.
- To avoid possible personal injury, a safe, flat surface for service personnel should be provided.
- As indicated on the unit's data plate, a minimum clearance of 36" to any combustible material is required on the access side of the unit. All combustible materials must be kept out of this area.
- This 36" clearance must also be maintained to insure proper combustion air flow. The combustion air intake must not be blocked for any reason, including blockage by snow.
- Adequate clearances from the unit to any adjacent public walkways, adjacent buildings, building openings or openable windows must be maintained in accordance with National Codes.

- Do not stand or walk on the unit.
- Do not drill holes anywhere in panels or in the base frame of the unit (except where indicated). Unit access panels provide structural support.
- Do not remove any access panels until unit has been installed on roof curb or field supplied structure.
- Do not roll unit across finished roof without prior approval of owner or architect.
- Do not skid or slide on any surface as this may damage unit base. The unit must be stored on a flat, level surface. Protect the condenser coil because it is easily damaged.

ROOF CURB INSTALLATIONS ONLY:

Before installing this unit...

IMPORTANT NOTE: This unit has been equipped with a shipping brace under the compressor section that **MUST BE REMOVED** before installing the unit on a roof curb.

Please follow the instructions below to remove brace.

 CAUTION
WHEN UNIT IS SUSPENDED, BOARDS AND SHIPPING BRACE WILL DROP WHEN SCREWS ARE REMOVED. TO PREVENT PERSONAL INJURY, STAND CLEAR. REMOVE FORK HOLE BRACKETS, BOARDS AND SHIPPING BRACE FROM BOTTOM OF UNIT BEFORE PLACING UNIT ONTO CURB.

1. Remove wooden struts and shipping brace per installation instructions. *The struts are located in the fork holes and are used to protect the unit from damage while lifting with forks. The shipping brace is located underneath the unit (under compressors).* Also remove the fork hole brackets as shown in the following figure.
2. Locate and remove the end brackets as shown in the following graphic.

UNIT PRECAUTIONS

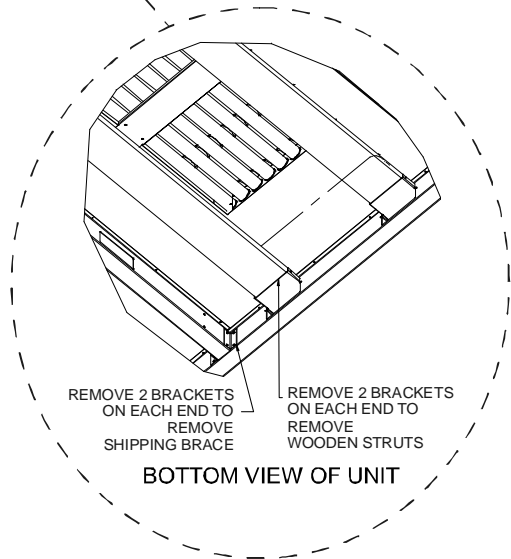
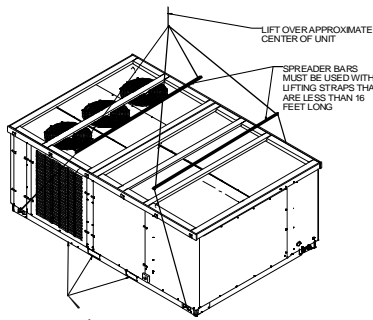

3. Lift unit per the "Rigging Details" section of this manual, observing all warnings and cautions. When unit is lifted, boards and shipping brace will drop if screws have been removed. To avoid injury, STAND CLEAR.
4. Dispose of the boards and brace appropriately.

Curb installations must comply with local codes and should be done in accordance with the established guidelines of the National Roofing Contractors Association.

Proper unit installation requires that the roof curb be firmly and permanently attached to the roof structure. Check for adequate fastening method prior to setting the unit on the curb.

Full perimeter roof curbs are available from the factory and are shipped unassembled. Field assembly, squaring, leveling and mounting on the roof structure are the responsibility of the installing contractor. All required hardware necessary for the assembly of the sheet metal curb is included in the curb accessory.

- Sufficient structural support must be determined prior to locating and mounting the curb and package unit.
- Ductwork must be constructed using industry guidelines. The duct work must be placed into the roof curb before mounting the package unit. Our full perimeter curbs include duct connection frames to be assembled with the curb. Cantilevered type curbs are not available from the factory.
- Curb insulation, cant strips, flashing and general roofing material are furnished by the contractor.

The curbs must be supported on parallel sides by roof members. The roof members must not penetrate supply and return duct opening areas as damage to the unit might occur.

NOTE: The unit and curb accessories are designed to allow vertical duct installation before unit placement. Duct installation after unit placement is not recommended.

CAUTION
<p>ALL CURBS LOOK SIMILAR. TO AVOID INCORRECT CURB POSITIONING, CHECK JOB PLANS CAREFULLY AND VERIFY MARKINGS ON CURB ASSEMBLY. INSTRUCTIONS MAY VARY IN CURB STYLES AND SUPERSEDES INFORMATION SHOWN.</p>

See the manual shipped with the roof curb for assembly and installation instructions.

CLEARANCES

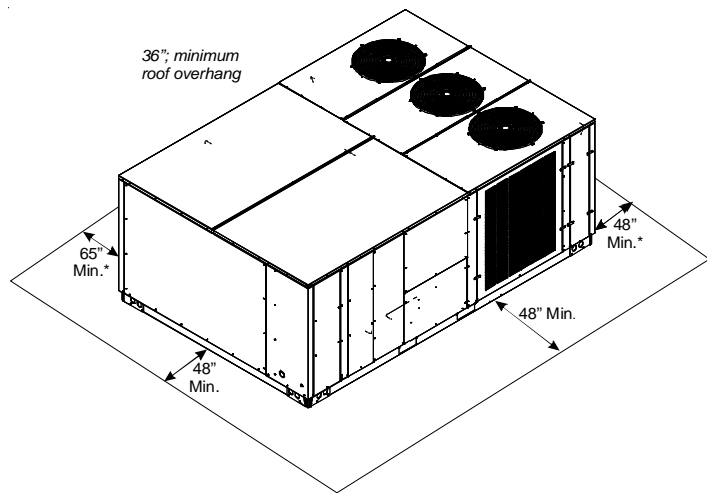

**In situations that have multiple units, a 48" minimum clearance is required between the condenser coils.*

UNIT CLEARANCES

Adequate clearance around the unit should be kept for safety, service, maintenance, and proper unit operation. A total clearance of 75" around this unit is recommended to facilitate possible blower assembly, shaft, wheel replacement, coil, heat exchanger, electric heat and gas furnace removal. This unit must not be installed beneath any obstruction. This unit should be installed remote from all building exhausts to inhibit ingestion of exhaust air into the unit's fresh air intake.

WARNING
<p>TO PREVENT POSSIBLE EQUIPMENT DAMAGE, PROPERTY DAMAGE, PERSONAL INJURY OR DEATH, THE FOLLOWING BULLET POINTS MUST BE OBSERVED WHEN INSTALLING THE UNIT.</p>

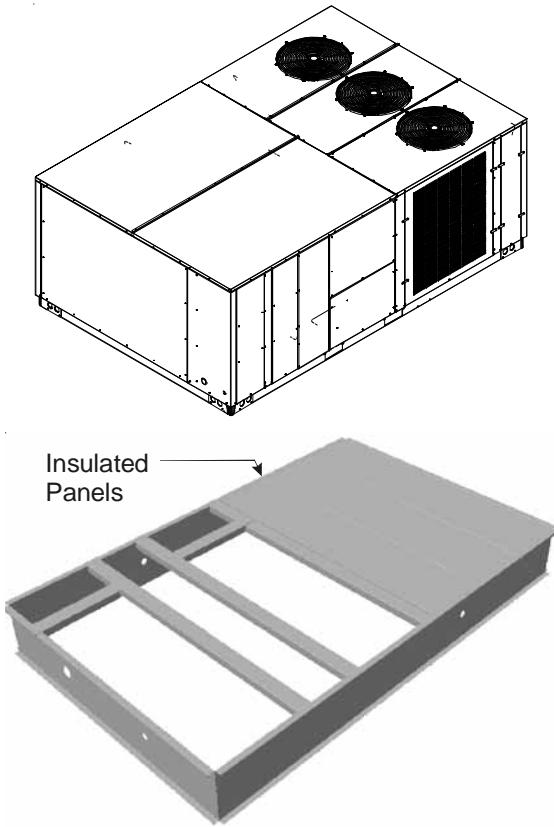

Roof Curb Installation

ROOF CURB POST-INSTALLATION CHECKS

After installation, check the top of the curb, duct connection frame and duct flanges to make sure gasket has been applied properly. Gasket should be firmly applied to the top of the curb perimeter, duct flanges and any exposed duct connection frame. If gasket is loose, re-apply using strong weather resistant adhesive.

PROTRUSION

Inspect curb to ensure that none of the utility services (electric) routed through the curb protrude above the curb.

CAUTION

IF PROTRUSIONS EXIST, DO NO ATTEMPT TO SET UNIT ON CURB.

ROOF TOP DUCT CONNECTIONS

Install all duct connections on the unit before placing the unit on rooftop.

RIGGING DETAILS

WARNING

TO PREVENT PROPERTY DAMAGE, THE UNIT SHOULD REMAIN IN AN UPRIGHT POSITION DURING ALL RIGGING AND MOVING OPERATIONS. TO FACILITATE LIFTING AND MOVING WHEN A CRANE IS USED, PLACE THE UNIT IN AN ADEQUATE CABLE SLING.

CAUTION

DO NOT LIFT UNITS TWO AT A TIME. PROVISIONS FOR FORKS HAVE BEEN INCLUDED IN THE UNIT BASE FRAME. MINIMUM FORK LENGTH IS 72" TO PREVENT DAMAGE TO THE UNIT.

Provisions for forks have been included in the unit base frame. No other fork locations are approved.

WARNING

TO PREVENT POSSIBLE EQUIPMENT DAMAGE, PROPERTY DAMAGE, PERSONAL INJURY OR DEATH, THE FOLLOWING BULLET POINTS MUST BE OBSERVED WHEN INSTALLING THE UNIT.

- Unit must be lifted by the four lifting holes located at the base frame corners.
- Lifting cables should be attached to the unit with shackles.
- The distance between the crane hook and the top of the unit must not be less than 60".
- Two spreader bars must span over the unit to prevent damage to the cabinet by the lift cables. Spreader bars must be of sufficient length so that cables do not come in contact with the unit during transport. Remove wood struts mounted beneath unit base frame before setting unit on roof curb. These struts are intended to protect unit base frame from fork lift damage. Removal is accomplished by extracting the sheet metal retainers and pulling the struts through the base of the unit. Refer to rigging label on the unit.

Important: If using bottom discharge with roof curb, ductwork should be attached to the curb prior to installing the unit. Ductwork dimensions are shown in Roof Curb Installation Instructions.

Refer to the Roof Curb Installation Instructions for proper curb installation. Curbing must be installed in compliance with the National Roofing Contractors Association Manual.

Lower unit carefully onto roof mounting curb. While rigging unit, center of gravity will cause condenser end to be lower than supply air end.

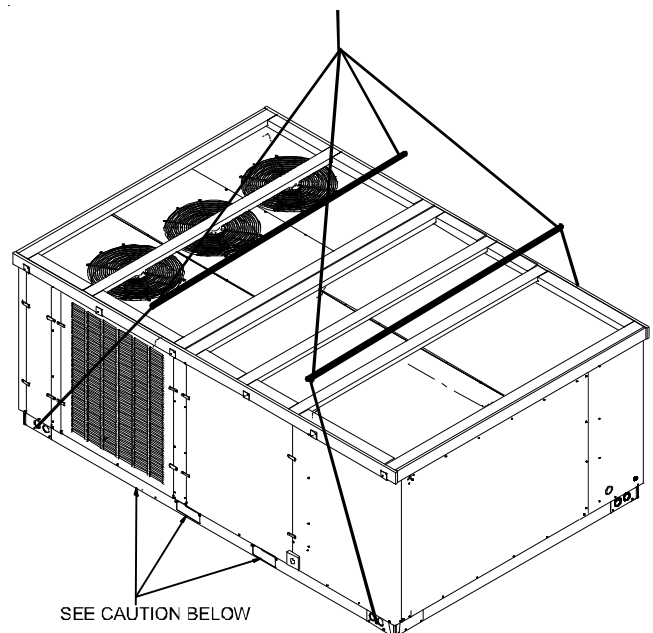

CAUTION

WHEN UNIT IS SUSPENDED, BOARDS AND SHIPPING BRACE WILL DROP WHEN SCREWS ARE REMOVED. TO PREVENT PERSONAL INJURY, STAND CLEAR. REMOVE FORK HOLE BRACKETS, BOARDS AND SHIPPING BRACE FROM BOTTOM OF UNIT BEFORE PLACING UNIT ONTO CURB.

To assist in determining rigging requirements, unit weights are shown as follows:

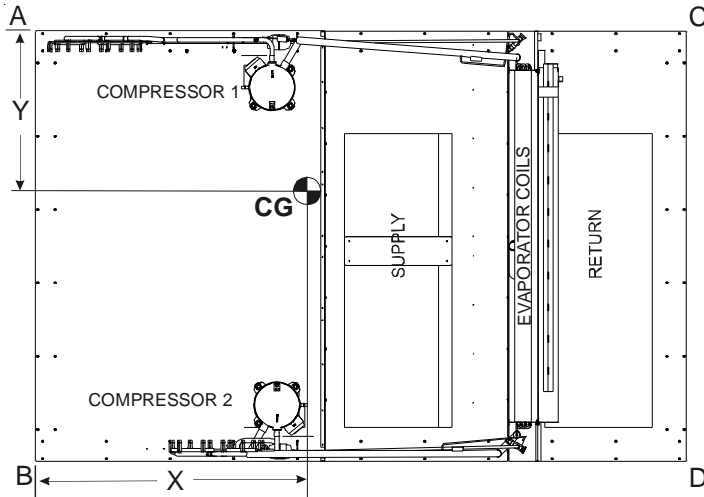

CORNER & CENTER OF GRAVITY LOCATIONS

DATA	DCC Weights (lbs)		
	15 Tons	20 Tons	25 Tons
Corner Weight - A	590	644	626
Corner Weight - B	482	525	464
Corner Weight - C	492	504	501
Corner Weight - D	401	412	518
Unit Shipping Weight	2080	2202	2377
Unit Operating Weight	1965	2085	2109
X (Inches)	60"	58"	64.3"
Y (Inches)	40"	40"	41.3"

NOTE: These weights are without accessories installed.

CAUTION

TO PREVENT SEVERE DAMAGE TO THE BOTTOM OF THE UNIT, DO NOT FORK LIFT UNIT AFTER WOOD STRUTS HAVE BEEN REMOVED.

Bring condenser end of unit into alignment with the curb. With condenser end of the unit resting on curb member and using curb as a fulcrum, lower opposite end of the unit until entire unit is seated on the curb. When a rectangular cantilever curb is used, care should be taken to center the unit. Check for proper alignment and orientation of supply and return openings with duct.

RIGGING REMOVAL

CAUTION

TO PREVENT DAMAGE TO THE UNIT, DO NOT ALLOW CRANE HOOKS AND SPREADER BARS TO REST ON THE ROOF OF THE UNIT.

Remove spreader bars, lifting cables and other rigging equipment.

ELECTRICAL WIRING

WARNING

HIGH VOLTAGE! DISCONNECT ALL POWER BEFORE SERVICING OR INSTALLING THIS UNIT. MULTIPLE POWER SOURCES MAY BE PRESENT. FAILURE TO DO SO MAY CAUSE PROPERTY DAMAGE, PERSONAL INJURY OR DEATH.



WARNING

HIGH VOLTAGE! TO AVOID PERSONAL INJURY OR DEATH DUE TO ELECTRICAL SHOCK, DO NOT TAMPER WITH FACTORY WIRING. THE INTERNAL POWER AND CONTROL WIRING OF THESE UNITS ARE FACTORY-INSTALLED AND HAVE BEEN THOROUGHLY TESTED PRIOR TO SHIPMENT. CONTACT YOUR LOCAL REPRESENTATIVE IF ASSISTANCE IS REQUIRED.



CAUTION

TO PREVENT DAMAGE TO THE WIRING, PROTECT WIRING FROM SHARP EDGES. FOLLOW NATIONAL ELECTRICAL CODE AND ALL LOCAL CODES AND ORDINANCES. DO NOT ROUTE WIRES THROUGH REMOVABLE ACCESS PANELS.

CAUTION

CONDUIT AND FITTINGS MUST BE WEATHER-TIGHT TO PREVENT WATER ENTRY INTO THE BUILDING.

For unit protection, use a fuse or HACR circuit breaker that is in excess of the circuit ampacity, but less than or equal to the maximum overcurrent protection device. DO NOT EXCEED THE MAXIMUM OVERCURRENT DEVICE SIZE SHOWN ON UNIT DATA PLATE.

All line voltage connections must be made through weatherproof fittings. All exterior power supply and ground wiring must be in approved weatherproof conduit.

The main power supply wiring to the unit and low voltage wiring to accessory controls must be done in accordance with these instructions, the latest edition of the National Electrical Code (ANSI/NFPA 70), and all local codes and ordinances. All field wiring shall conform with the temperature limitations for Type T wire (63°F/35°C rise).

The main power supply shall be three-phase, three wire. The unit is factory wired for the voltage shown on the unit's data plate.

NOTE: If supply voltage is 208V, all leads on primary of transformer TRANS1 must be moved from the 230V to the 208V tap.

Main power wiring should be sized for the minimum wire ampacity shown on the unit's data plate. Size wires in accordance with the ampacity tables in Article 310 of the National Electrical Code. If long wires are required, it may be necessary to increase the wire size to prevent excessive voltage drop. Wires should be sized for a maximum of 3% voltage drop.

CAUTION

TO AVOID PROPERTY DAMAGE OR PERSONAL INJURY DUE TO FIRE, USE ONLY COPPER CONDUCTORS.

CAUTION

LABEL ALL WIRES PRIOR TO DISCONNECTION WHEN SERVICING CONTROLS. WIRING ERRORS CAN CAUSE IMPROPER AND DANGEROUS OPERATION. VERIFY PROPER OPERATION AFTER SERVICING.

NOTE: A weather-tight disconnect switch, properly sized for the unit total load, must be field or factory installed. An external field supplied disconnect may be mounted on the exterior panel.

Ensure the data plate is not covered by the field-supplied disconnect switch.

- Some disconnect switches are not fused. Protect the power leads at the point of distribution in accordance with the unit's data plate.
- The unit must be electrically grounded in accordance with local codes or, in the absence of local codes, with the latest edition of the National Electrical Code (ANSI-NFPA 70). A ground lug is provided for this purpose. Size grounding conductor in accordance with Table 250-95 of the National Electrical Code. Do not use the ground lug for connecting a neutral conductor.
- Connect power wiring to the electrical middle contactor within the main control box of power block, if equipped.

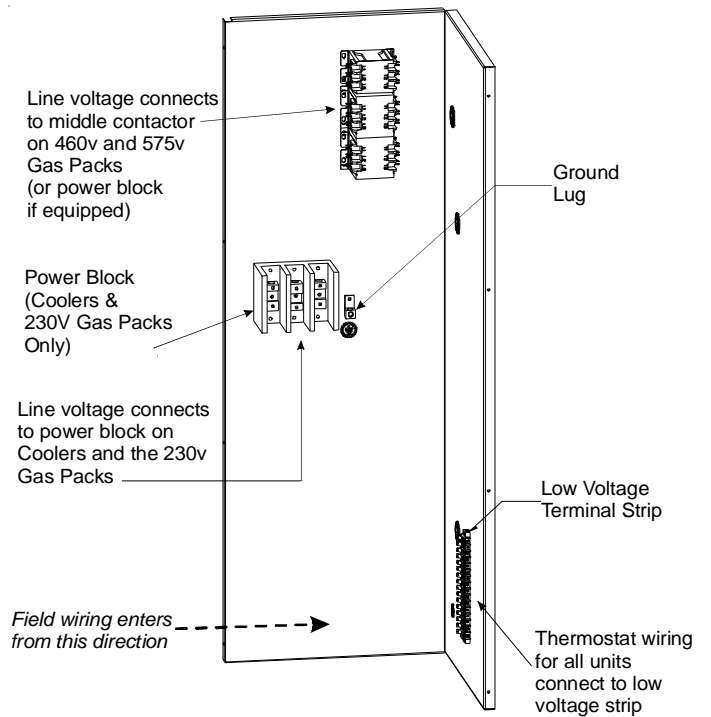

POWER AND LOW VOLTAGE BLOCK LOCATIONS

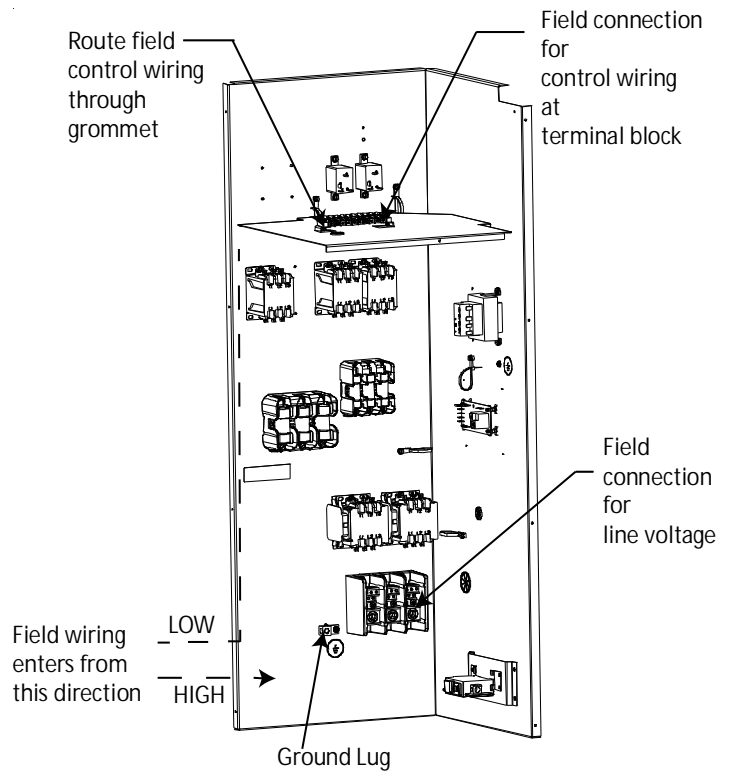

25 TON POWER AND LOW VOLTAGE BLOCK LOCATIONS

WARNING

FAILURE OF UNIT DUE TO OPERATION ON IMPROPER LINE VOLTAGE OR WITH EXCESSIVE PHASE UNBALANCE CONSTITUTES PRODUCT ABUSE AND MAY CAUSE SEVERE DAMAGE TO THE UNIT ELECTRICAL COMPONENTS.

Areas Without Convenience Outlet

It is recommended that an independent 115V power source be brought to the vicinity of the roof top unit for portable lights and tools used by the service mechanic.

NOTE: Refer to local codes for requirements. These outlets can also be factory installed.

UNITS INSTALLED ON ROOF TOPS

Main power and low voltage wiring may enter the unit through the side or through the roof curb. Install conduit connectors at the desired entrance locations. External connectors must be weathertight. All holes in the unit base must be sealed (including those around conduit nuts) to prevent water leakage into building. All required conduit and fittings are to be field supplied.

Supply voltage to roof top unit must not vary by more than 10% of the value indicated on the unit's data plate. Phase voltage unbalance must not exceed 2%. Contact your local power company for correction of improper voltage or phase unbalance.

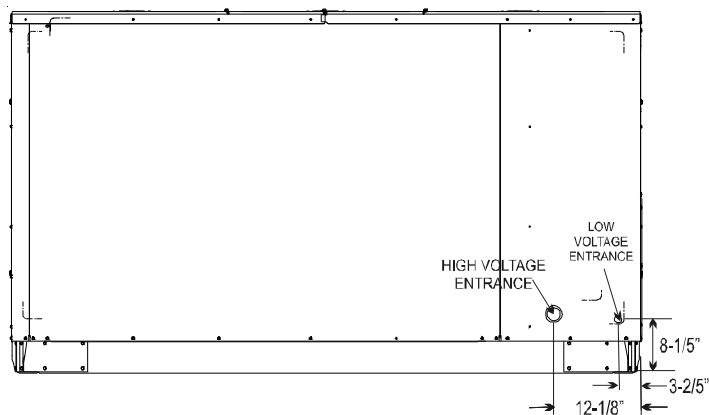

ELECTRICAL ENTRANCE LOCATIONS

Unit is equipped with Single Point Power Block and Low Voltage Block.

LOW VOLTAGE CONTROL WIRING

1. A 24V thermostat must be installed for unit operation. It may be purchased with the unit or field-supplied. Thermostats may be programmable or electromechanical as required.
2. Locate thermostat or remote sensor in the conditioned space where it will sense average temperature. Do not locate the device where it may be directly exposed to supply air, sunlight or other sources of heat. Follow installation instructions packaged with the thermostat.

3. Use #18 AWG wire for 24V control wiring runs not exceeding 75 feet. Use #16 AWG wire for 24V control wiring runs not exceeding 125 feet. Use #14 AWG wire for 24V control wiring runs not exceeding 200 feet. Low voltage wiring may be National Electrical Code (NEC) Class 2 where permitted by local codes.
4. Route thermostat wires from sub-base terminals to the unit. Control wiring should enter through the duct panel (dimple marks entrance location). Connect thermostat and any accessory wiring to low voltage terminal block TB1 in the main control box.

NOTE: Field-supplied conduit may need to be installed depending on unit/curb configuration. Use #18 AWG solid conductor wire whenever connecting thermostat wires to terminals on sub-base. DO NOT use larger than #18 AWG wire. A transition to #18 AWG wire may be required before entering thermostat sub-base.

NOTE: Refer to unit wiring diagrams for thermostat hookups.

CIRCULATING AIR AND FILTERS

DUCTWORK

The supply duct from the unit through a wall may be installed without clearance. However, minimum unit clearances must be maintained (see "Clearances" section). The supply duct should be provided with an access panel large enough to inspect the air chamber downstream of the heat exchanger. A cover should be tightly attached to prevent air leaks.

Ductwork dimensions are shown in the roof curb installation manual.

If desired, supply and return duct connections to the unit may be made with flexible connections to reduce possible unit operating sound transmission.

CONDENSATE DRAIN CONNECTION

CONDENSATE DRAIN CONNECTION

A 1" female NPT drain connection is supplied on the side of the unit and a 1" male NPT on the bottom of the drain pan for condensate piping. An external trap must be installed for proper condensate drainage.

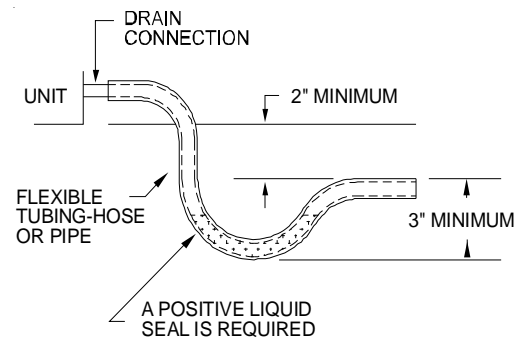

DRAIN CONNECTION

Install condensate drain trap as shown. Use 1" drain line and fit-

tings or larger. Do not operate without trap.

HORIZONTAL DRAIN

Drainage of condensate directly onto the roof may be acceptable; refer to local code. It is recommended that a small drip pad of either stone, mortar, wood or metal be provided to prevent any possible damage to the roof.

CLEANING

Due to the fact that drain pans in any air conditioning unit will have some moisture in them, algae and fungus will grow due to airborne bacteria and spores. Periodic cleaning is necessary to prevent this build-up from plugging the drain.

STARTUP, ADJUSTMENTS, AND CHECKS

WARNING

HIGH VOLTAGE!

TO AVOID PERSONAL INJURY OR DEATH DUE TO ELECTRICAL SHOCK, BOND THE FRAME OF THIS UNIT TO THE BUILDING ELECTRICAL GROUND BY USE OF THE GROUNDING TERMINAL PROVIDED OR OTHER ACCEPTABLE MEANS. DISCONNECT ALL POWER BEFORE SERVICING OR INSTALLING THIS UNIT.



PRE-STARTUP INSTRUCTIONS

CAUTION

TO PREVENT PROPERTY DAMAGE OR PERSONAL INJURY, Do NOT START THE UNIT UNTIL ALL NECESSARY PRE-CHECKS AND TESTS HAVE BEEN PERFORMED.

Prior to the beginning of Startup, Adjustments, and Checks procedures, the following steps should be completed in the building.

WARNING

MOVING MACHINERY HAZARD!

TO PREVENT POSSIBLE PERSONAL INJURY OR DEATH, DISCONNECT POWER TO THE UNIT AND PADLOCK IN THE "OFF" POSITION BEFORE SERVICING FANS.

HEATING STARTUP

On new installations, or if a major component has been replaced, the operation of the unit must be checked.

Check unit operation as outlined in the following instructions. If any sparking, odors, or unusual sounds are encountered, shut off electrical power and recheck for wiring errors, or obstructions in or near the blower motors. **Duct covers must be removed before operating unit.**

The Startup, Adjustments, and Checks procedure provides a step-

by-step sequence which, if followed, will assure the proper startup of the equipment in the minimum amount of time. Air balancing of duct system is not considered part of this procedure. However, it is an important phase of any air conditioning system startup and should be performed upon completion of the Startup, Adjustments, and Checks procedure. The Startup, Adjustments, and Checks procedure at outside ambients below 55°F should be limited to a readiness check of the refrigeration system with the required final check and calibration left to be completed when the outside ambient rises above 55°F.

TEMPORARY HEATING OR COOLING

If the unit is to be used for temporary heating or cooling, a "Startup, Adjustments, and Checks" must first be performed in accordance with this manual. **After** the machines are used for temporary heating or cooling, inspect the coils, fans, and motors for unacceptable levels of construction dust and dirt and install new filters.

CONTRACTOR RESPONSIBILITY

The installing contractor must be certain that:

- All supply and return air ductwork is in place, properly sealed and corresponds with installation instructions.
- All thermostats are mounted and wired in accordance with installation instructions.
- All electric power, all gas, hot water or steam line connections, and the condensate drain installation have been made to each unit on the job. These main supply lines must be functional and capable of operating all units simultaneously.
- All filters are in place.

ROOF CURB INSTALLATION CHECK

Inspect the roof curb for correct installation. The unit and curb assembly should be level. Inspect the flashing of the roof mounting curb to the roof, especially at the corners, for good workmanship. Also check for leaks around gaskets. Note any deficiencies in a separate report and forward to the contractor.

OBSTRUCTIONS, FAN CLEARANCE AND WIRING

Remove any extraneous construction and shipping materials that may be found during this procedure. Rotate all fans manually to check for proper clearances and that they rotate freely. Check for bolts and screws that may have jarred loose during shipment to the job site. Retighten if necessary. Re-tighten all electrical connections.

FIELD DUCT CONNECTIONS

Verify that all duct connections are tight and that there is no air bypass between supply and return.

FILTER SECTION CHECK

Remove filter section access panels and check that filters are properly installed. Note airflow arrows on filter frames.

PRE-STARTUP PRECAUTIONS

It is important to your safety that the unit has been properly grounded during installation. Check ground lug connection in main control box for tightness prior to closing circuit breaker or disconnect switch. Verify that supply voltage on line side of disconnect agrees with voltage on unit identification plate and is within the utilization voltage range as indicated in Appendix C Electrical Data.

System Voltage - That nominal voltage value assigned to a circuit or system for the purpose of designating its voltage class.

Nameplate Voltage - That voltage assigned to a piece of equipment for the purpose of designating its voltage class and for the purpose of defining the minimum and maximum voltage at which the equipment will operate.

Utilization Voltage - The voltage of the line terminals of the equipment at which the equipment must give fully satisfactory performance. Once it is established that supply voltage will be maintained within the utilization range under all system conditions, check and calculate if an unbalanced condition exists between phases. Calculate percent voltage unbalance as follows:

Three Phase Models Only

$$3) \text{ PERCENT VOLTAGE UNBALANCE} = 100 \times \frac{2) \text{ MAXIMUM VOLTAGE DEVIATIONS FROM AVERAGE VOLTAGE}}{1) \text{ AVERAGE VOLTAGE}}$$

HOW TO USE THE FORMULA:

EXAMPLE: With voltage of 220, 216, and 213

1) Average Voltage = $220+216+213=649 / 3 = 216$

2) Maximum Voltage Deviations from Average Voltage = $220 - 216 = 4$

3) Percent Voltage Unbalance = $100 \times \frac{4}{216} = \frac{400}{216} = 1.8\%$

Percent voltage unbalance MUST NOT exceed 2%.

AIRFLOW ADJUSTMENTS

NOTE: For 2 Speed Models, airflow adjustments must be made on high speed, i.e., 2nd stage cooling or in heat mode.

The drive on the supply fan is typically set in the middle of the RPM range. The drive motor sheave pitch diameter is field adjustable for the required airflow. Refer to the following "Drive Adjustments" section.

When the final adjustments are complete, the current draw of the motor should be checked and compared to the full load current rating of the motor. The amperage must not exceed the service factor stamped on the motor nameplate. The total airflow must not be less than that required for operation of the electric heaters or the furnace.

If an economizer is installed, check the unit operating balance with

the economizer at full outside air and at minimum outside air. Upon completion of the air flow balancing, we recommend replacing the variable pitched motor sheave with a properly-sized fixed sheave. A matching fixed sheave will provide longer belt and bearing life and vibration free operation. Initially, it is best to have a variable pitched motor sheave for the purpose of airflow balancing, but once the balance has been achieved, fixed sheaves maintain alignment and minimize vibration more effectively. For direct drive units, move green wire for fan.

NOTE: On "non-two speed models" (two-speed models have a "V" in the eleventh character of the model number), never run CFM below 300 CFM per ton. Evaporator freezing or poor unit performance is possible.

SET EVAPORATOR FAN RPM

Actual RPM's must be set and verified with a tachometer or strobe light. Refer to Appendices A and B for basic unit fan RPM. Refer also to "Airflow" section of this manual. With disconnect switch open, disconnect thermostat wires from terminals Y and W. This will prevent heating and mechanical cooling from coming on. Place a jumper wire across terminals R and G at TB1 terminal block. Close disconnect switch; evaporator fan motor will operate so RPM can be checked.

EVAPORATOR FAN ROTATION CHECK (THREE PHASE MODELS ONLY)

Check that fan rotates clockwise when viewed from the drive side of unit and in accordance with rotation arrow shown on blower housing. If it does not, reverse the two incoming power cables at Single Point Power Block. In this case, repeat bearing check.

Do not attempt to change load side wiring. Internal wiring assures all motors and compressors will rotate in correct direction once evaporator fan motor rotation check has been made.

ELECTRICAL INPUT CHECK

Make preliminary check of evaporator fan ampere draw and verify that motor nameplate amps are not exceeded. A final check of amp draw should be made upon completion of air balancing of the duct system (see Appendix C).

BELT DRIVE MODELS ONLY

BEARING CHECK

Prior to energizing any fans, check and make sure that all setscrews are tight so that bearings are properly secured to shafts.

TENSION AND ALIGNMENT ADJUSTMENT

Correct belt tension is very important to the life of your belt. Too loose a belt will shorten its life; too tight, premature motor and bearing failure will occur. Check you belt drive for adequate "run-in" belt tension by measuring the force required to deflect the belt at the midpoint of the span length. Belt tension force can be measured using a belt tension gauge, available through most belt drive manufacturers.

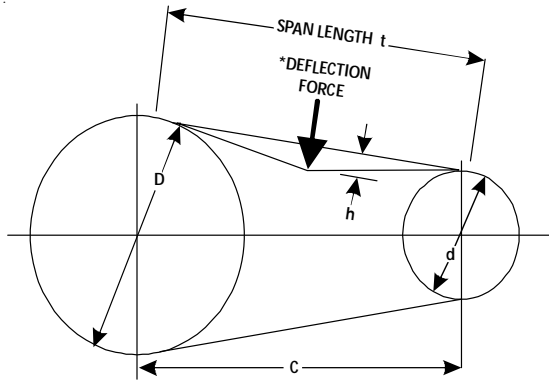

*Apply force to the center of the span.

- t = Span length, inches
- C = Center distance, inches
- D = Larger sheave diameter, inches
- d = Smaller sheave diameter, inches
- h = Deflection height, inches

DRIVE BELT TENSION ADJUSTMENT

MODEL	TYPE		SHEAVE DIAMETER (in)	DEFLECTION FORCE (lbs)		DEFLECTION (in)
	BELT	DRIVE		Used	New	
15 Ton	B, BX	Standard	4.3 to 5.5	5.5 ± .5	8.2 ± .5	1/4 ± 1/16
20 Ton	B, BA	Standard	4.3 to 5.5	5.5 ± .5	8.2 ± .5	1/4 ± 1/16
25 Ton						

RECOMMENDED POUNDS OF FORCE PER BELT

New V-belts will drop rapidly during the first few hours of use. Check tension frequently during the first 24 hours of operation. Tension should fall between the minimum and maximum force. To determine the deflection distance from a normal position, measure the distance from sheave to sheave using a straightedge or a cord. This is your reference line. On multiple belt drives, an adjacent undeflected belt can be used as a reference.

MOTOR SHEAVE ADJUSTMENTS

VL, VM & 2VP VARIABLE PITCH KEY TYPE MOTOR SHEAVES

The driving and driven motor sheaves should be in alignment with each other and the shafts parallel.

VL & VM SHEAVES ADJUSTMENT

1. Loosen set screw "B" using a 5/32" Allen key.
2. Making half or full turns from closed position, adjust sheave pitch diameter for desired speed. DO NOT OPEN MORE THAN SIX FULL TURNS.
3. Tighten set screw "B" securely over flat.
4. Carefully put on belts and adjust belt tension. DO NOT FORCE BELTS OVER GROOVES.
5. Ensure all keys are in place and the set screws tight before starting drive. Recheck set screws and belt tension after 24 hours service.

NOTE: Future adjustments should be made by loosening the belt tension and increasing or decreasing the pitch diameter of the sheave by half or full turns as required. Readjust belt tension before starting drive.

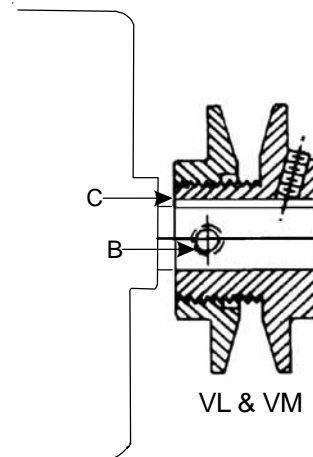

NOTE: Do not operate sheave with flange projecting beyond the hub end.

REFRIGERATION SYSTEM

The unit is equipped with a thermal expansion valve as a metering device.

Ensure the hold-down bolts on the compressor are secure and have not vibrated loose during shipment. Check that vibration grommets have been installed. Visually check all piping for damage and leaks; repair if necessary. The entire system has been factory charged and tested, making it unnecessary to field charge. Factory charges are shown on the unit's nameplate. To confirm charge levels or, if a leak occurs and charge needs to be added to the system, it is recommended to evacuate the system and recharge refrigerant to unit nameplate specifications. This unit has been rated in the cooling mode at the AHRI rated conditions of: Indoor (80°db / 67°wb) and outdoor (95°db). While operating at this condition, the subcooling should range from 12° to 15° F for each refrigeration circuit, for 15 and 20 ton models. Subcooling for 25 ton models should be from 16° to 19° F for circuit 1, and from 12° to 15° F for circuit 2.

START-UP PROCEDURE AND CHECKLIST

Begin with power turned off at all disconnects.

1. Turn thermostat system switch to "Cool," and fan switch to "Auto" and turn temperature setting as high as it will go.
2. Inspect all registers and set them to the normal open position.
3. Turn on the electrical supply at the disconnect.
4. Turn the fan switch to the "ON" position. The blower

should operate after a 7-second delay.

5. Turn the fan switch to "Auto" position. The blower should stop after a 65 second delay.
6. Slowly lower the cooling temperature until first stage COOL (LOW COOL) starts. The blower, both fans, and first stage compressor should now be operating. Allow the unit to run 10 minutes, make sure cool air is being supplied by the unit.
7. Lower the cooling temperature further until second stage COOL (HIGH COOL) starts. The blower, both fans, and both compressors should now be operating. Allow the unit to run 10 minutes, make sure cool air is being supplied by the unit.
8. Turn the temperature setting to the highest position, stopping the unit. The indoor blower will continue to run for 65 seconds.
9. Turn the thermostat system switch to "OFF" and disconnect all power when servicing the unit.

START-UP PROCEDURE AND CHECKLIST FOR 2 SPEED MODELS:

Models with a V in the 11th position of the model number.

For 2 speed models, the indoor blower will operate on low speed when in "Fan Only" mode or while in first stage "Cooling" mode. Unit will operate on high speed in "Heating" mode and while in second stage "Cooling" mode.

The start-up procedure is the same as for "Air Conditioning Start-up Procedure" with the understanding that in Step 6, the indoor blower will run at low speed (~1175 motor rpm) and in Step 7, the indoor blower will operate at high speed (~1775 motor rpm).

NOTE: While in the Cooling Mode, to prevent frost from forming on the evaporator while the unit is operating in outdoor temperatures of 65°F or lower, it is recommended that a low ambient kit (LAKT-**) is used. This is strongly recommended for 2 Speed models due to the lower airflow while in the first stage cooling. To further protect the compressor from damage during low ambient conditions, a Freezestat Kit (FSK01) can be added that turns the compressor off when the evaporator temperature drops too low.

WARNING

HIGH VOLTAGE!

DISCONNECT ALL POWER BEFORE SERVICING OR INSTALLING THIS UNIT. MULTIPLE POWER SOURCES MAY BE PRESENT. FAILURE TO DO SO MAY CAUSE PROPERTY DAMAGE, PERSONAL INJURY OR DEATH.



FINAL SYSTEM CHECKS

10. Check to see if all supply and return air grilles are adjusted and the air distribution system is balanced for the best compromise between heating and cooling.
11. Check for air leaks in the ductwork. See Sections on **Air Flow Adjustments**.
12. Make sure the unit is free of "rattles", and the tubing in the unit is free from excessive vibration. Also make sure tubes or lines are not rubbing against each other or sheet metal surfaces or edges. If so, correct the trouble.
13. Set the thermostat at the appropriate setting for cooling and heating or automatic change over for normal use.
14. Be sure the Owner is instructed on the unit operation, filter, servicing, correct thermostat operation, etc.

MAINTENANCE

WARNING

HIGH VOLTAGE!

DISCONNECT ALL POWER BEFORE SERVICING OR INSTALLING THIS UNIT. MULTIPLE POWER SOURCES MAY BE PRESENT. FAILURE TO DO SO MAY CAUSE PROPERTY DAMAGE, PERSONAL INJURY OR DEATH.



WARNING

TO PREVENT PERSONAL INJURY OR DEATH DUE TO IMPROPER INSTALLATION, ADJUSTMENT, ALTERATION, SERVICE OR MAINTENANCE, REFER TO THIS MANUAL. FOR ADDITIONAL ASSISTANCE OR INFORMATION, CONSULT A QUALIFIED INSTALLER, SERVICE AGENCY OR THE GAS SUPPLIER.



CAUTION

SHEET METAL PARTS, SCREWS, CLIPS AND SIMILAR ITEMS INHERENTLY HAVE SHARP EDGES, AND IT IS NECESSARY THAT THE INSTALLER AND SERVICE PERSONNEL EXERCISE CAUTION.

Preventive maintenance is the best way to avoid unnecessary expense and inconvenience. Have this system inspected at regular intervals by qualified service personnel, at least twice a year. Routine maintenance should cover the following items:

1. Tighten all belts, set screws, and wire connections.
2. Clean evaporator and condenser coils mechanically or with cold water, if necessary. Usually any fouling is only matted on the entering air face of the coil and can be removed by brushing.
3. Lubricate motor bearings.
4. Align or replace belts as needed.
5. Replace filters as needed (see below).
6. Check for blockage of condensate drain.
7. Check power and control voltages.
8. Check running amperage.
9. Check operating temperatures and pressures.
10. Check and adjust temperature and pressure controls.
11. Check and adjust damper linkages.
12. Check operation of all safety controls.
13. Examine gas furnaces (see below and the User's Information Manual).
14. Check condenser fans and tighten set screws.

FILTERS



CAUTION

TO PREVENT PROPERTY DAMAGE DUE TO FIRE AND LOSS OF EQUIPMENT EFFICIENCY OR EQUIPMENT DAMAGE DUE TO DUST AND LINT BUILD UP ON INTERNAL PARTS, NEVER OPERATE UNIT WITHOUT AN AIR FILTER INSTALLED IN THE RETURN AIR SYSTEM.

Every application may require a different frequency of replacement of dirty filters. Filters must be replaced at least every three (3) months during operating seasons.

Dirty filters are the most common cause of inadequate heating or cooling performance. Filter inspection should be made at least every two months; more often if necessary because of local conditions and usage.

Dirty throwaway filters should be discarded and replaced with a new, clean filter.

Disposable return air filters are supplied with this unit. See the unit Specification Sheet or Technical Manual for the correct size and part number. To remove the filters, remove the filter access panel on return side of the unit.

CABINET FINISH MAINTENANCE

Use a fine grade automotive wax on the cabinet finish to maintain the finish's original high luster. This is especially important in installations with extended periods of direct sunlight.

CLEAN OUTSIDE COIL (QUALIFIED SERVICER ONLY)

The coil with the outside air flowing over it should be inspected annually and cleaned as frequently as necessary to keep the finned areas free of lint, hair and debris.

CONDENSER FANS

Bearings on the condenser fan motors are permanently lubricated. No additional oiling is required.

LUBRICATION

The fan shaft bearings and the supply fan motor have grease fittings that should be lubricated during normal maintenance checks.

FUNCTIONAL PARTS

Refer to the unit Parts Catalog for a list of functional parts. Parts are available from your distributor.

APPENDIX A BLOWER PERFORMANCE DATA BELT DRIVE - STANDARD

DCC180 STANDARD BELT DRIVE (includes 2 speed models at high speed)

ESP, In H ₂ O	TURNS OPEN													
	0		1		2		3		4		5		6	
	CFM	BHP	CFM	BHP	CFM	BHP	CFM	BHP	CFM	BHP	CFM	BHP	CFM	BHP
0.2	---	---	---	---	---	---	---	---	---	---	7203	2.18	6718	1.94
0.4	---	---	---	---	---	---	7306	2.54	6777	2.14	6257	1.80	5711	1.66
0.6	---	---	7477	2.97	6899	2.51	6323	2.10	5716	1.72	5103	1.39	---	---
0.8	7112	2.96	6467	2.46	5795	2.01	5101	1.61	---	---	---	---	---	---
1.0	5983	2.38	5190	1.89	---	---	---	---	---	---	---	---	---	---
1.2	4426	1.71	---	---	---	---	---	---	---	---	---	---	---	---

DCC240 STANDARD BELT DRIVE (includes 2 speed models at high speed)

ESP, In H ₂ O	TURNS OPEN													
	0		1		2		3		4		5		6	
	CFM	BHP	CFM	BHP	CFM	BHP	CFM	BHP	CFM	BHP	CFM	BHP	CFM	BHP
0.2	---	---	---	---	---	---	---	---	---	---	---	---	9664	4.05
0.4	---	---	---	---	---	---	---	---	9570	4.08	9197	3.82	8702	3.51
0.6	---	---	---	---	---	---	9038	3.82	8460	3.46	7949	3.14	---	---
0.8	---	---	8171	2.93	7630	3.70	7068	2.79	---	---	---	---	---	---
1.0	---	---	7901	2.85	7203	3.42	---	---	---	---	---	---	---	---
1.2	7344	4.35	---	---	---	---	---	---	---	---	---	---	---	---

DCC300 STANDARD BELT DRIVE (includes 2 speed models at high speed)

ESP, In H ₂ O	TURNS OPEN													
	0		1		2		3		4		5		6	
	CFM	BHP	CFM	BHP	CFM	BHP	CFM	BHP	CFM	BHP	CFM	BHP	CFM	BHP
0.2	---	---	---	---	---	---	10369	5.07	9748	4.41	9191	3.82	8683	3.28
0.4	---	---	10802	6.00	10125	5.30	9484	4.62	8905	4.01	8386	3.46	7913	2.95
0.6	10519	6.20	9821	5.47	9193	4.81	8599	4.18	8062	3.61	7582	3.10	7143	2.63
0.8	9482	5.60	8839	4.93	8261	4.32	7714	3.74	7220	3.21	6777	2.74	---	---
1.0	8446	5.01	7857	4.39	7329	3.83	6829	3.30	---	---	---	---	---	---
1.2	7409	4.41	6876	3.85	---	---	---	---	---	---	---	---	---	---

NOTES:

High static airflow requires installation of high static kit.

Unit factory shipped with sheave set at 2.5 turns open.

Air flow table represent dry coil with filters installed; SCFM correction factor for wet coil is 4%.

APPENDIX A BLOWER PERFORMANCE DATA BELT DRIVE - HIGH STATIC

DCC180 HIGH STATIC BELT DRIVE (includes 2 speed models at high speed)

ESP, In H ₂ O	TURNS OPEN													
	0		1		2		3		4		5		6	
	CFM	BHP	CFM	BHP	CFM	BHP	CFM	BHP	CFM	BHP	CFM	BHP	CFM	BHP
1.0	---	---	---	---	---	---	---	---	---	---	7120	3.26	6223	2.55
1.2	---	---	---	---	---	---	---	---	6927	3.39	5924	2.61	---	---
1.4	---	---	---	---	---	---	6739	3.52	5602	2.65	---	---	---	---
1.6	---	---	---	---	6587	3.69	5245	2.67	---	---	---	---	---	---
1.8	---	---	6419	3.84	4877	2.70	---	---	---	---	---	---	---	---
2.0	6261	4.01	---	---	---	---	---	---	---	---	---	---	---	---

DCC240 HIGH STATIC BELT DRIVE (includes 2 speed models at high speed)

ESP, In H ₂ O	TURNS OPEN													
	0		1		2		3		4		5		6	
	CFM	BHP	CFM	BHP	CFM	BHP	CFM	BHP	CFM	BHP	CFM	BHP	CFM	BHP
1.0	---	---	---	---	---	---	---	---	9090	5.79	8297	5.06	7479	3.62
1.2	---	---	---	---	---	---	8774	5.60	7914	4.83	6989	4.07	---	---
1.4	---	---	---	---	8471	5.43	7549	4.63	---	---	---	---	---	---
1.6	---	---	8209	6.14	7194	4.45	---	---	---	---	---	---	---	---
1.8	7967	6.02	6883	5.01	---	---	---	---	---	---	---	---	---	---
2.0	6594	4.87	---	---	---	---	---	---	---	---	---	---	---	---

DCC300 HIGH STATIC BELT DRIVE (includes 2 speed models at high speed)

ESP, In H ₂ O	TURNS OPEN													
	0		1		2		3		4		5		6	
	CFM	BHP	CFM	BHP	CFM	BHP	CFM	BHP	CFM	BHP	CFM	BHP	CFM	BHP
0.6	---	---	---	---	---	---	---	---	---	---	---	---	11409	7.12
0.8	---	---	---	---	---	---	---	---	---	---	---	---	10302	6.46
1.0	---	---	---	---	---	---	---	---	---	---	10159	6.79	9195	5.79
1.2	---	---	---	---	---	---	---	---	9990	7.11	8961	6.04	8087	5.13
1.4	---	---	---	---	---	---	9789	7.39	8686	6.25	7763	5.29	6980	4.46
1.6	---	---	---	---	9543	7.63	8357	6.40	7382	5.39	6566	4.53	---	---
1.8	---	---	---	---	7957	6.48	6925	5.41	6077	4.53	---	---	---	---
2.0	---	---	7667	6.68	6370	5.34	---	---	---	---	---	---	---	---
2.2	7280	6.78	---	---	---	---	---	---	---	---	---	---	---	---

NOTES:

High static airflow requires installation of high static kit.

Unit factory shipped with sheave set at 2.5 turns open.

Air flow table represent dry coil with filters installed; SCFM correction factor for wet coil is 4%.

APPENDIX B ELECTRICAL DATA

ELECTRICAL DATA

MODELS	VOLTAGE (NAMEPLATE)	VOLTAGE LIMITATIONS		COMPRESSOR (ea)			OD FAN MOTORS (ea)			ID MOTOR APPL	ID FAN MOTOR		2-SPEED ID FAN MOTOR	
		MIN	MAX	Qty	RLA	LRA	Qty	HP	RLA		HP	FLA	HP	FLA
15 TON	208/230-60-3	187	253	2	25.0	164.0	3	1/3	2.40	BD STD STATIC	3.0	9.2	3.0	9.1
	460-60-3	414	506	2	12.2	100.0	3	1/3	1.20	BD STD STATIC	3.0	4.6	3.0	4.3
	575-60-3	518	633	2	9.0	78.0	3	1/3	0.90	BD STD STATIC	3.0	4.2	3.0	3.5

ELECTRICAL DATA

MODELS	VOLTAGE (NAMEPLATE)	VOLTAGE LIMITATIONS		COMPRESSOR (ea)			OD FAN MOTORS (ea)			ID MOTOR APPL	ID FAN MOTOR		2-SPEED ID FAN MOTOR	
		MIN	MAX	Qty	RLA	LRA	Qty	HP	RLA		HP	FLA	HP	FLA
20 TON	208/230-60-3	187	253	2	33.3	239.0	3	1/3	2.40	BD STD STATIC	5.0	12.7	5.0	14.0
	460-60-3	414	506	2	17.9	125.0	3	1/3	1.20	BD STD STATIC	5.0	6.4	5.0	6.6
	575-60-3	518	633	2	12.8	80.0	3	1/3	0.90	BD STD STATIC	5.0	5.1	5.0	5.2

ELECTRICAL DATA

MODELS	VOLTAGE (NAMEPLATE)	VOLTAGE LIMITATIONS		COMPRESSOR (ea)			OD FAN MOTORS (ea)			ID MOTOR APPL	ID FAN MOTOR	
		MIN	MAX	Qty	RLA	LRA	Qty	HP	RLA		HP	FLA
25 TON	208/230-60-3	187	253	2	48.1	245.0	2	1	4.5	BD STD STATIC	7.5	20.4
	460-60-3	414	506	2	18.6	125.0	2	1	2.1	BD STD STATIC	7.5	9.4
	575-60-3	518	633	2	14.7	100.0	2	1	1.61	BD STD STATIC	7.5	7.5

NOTE: See unit nameplate for proper overcurrent protection.

UNIT	HEATER KIT MODEL NUMBER	MINIMUM CFM Downshot	HEATER KIT MODEL NUMBER	MINIMUM CFM Downshot	HEATER KIT MODEL NUMBER	MINIMUM CFM Downshot
15 TON	EHK3-31	5250	EHK4-31	5250	EHK7-31	5250
	EHK3-46	5250	EHK4-46	5250	EHK7-46	5250
	EHK3-60	5250	EHK4-60	5250	EHK7-60	5250
20 TON	EHK3-31	7000	EHK4-31	7000	EHK7-31	7000
	EHK3-46	7000	EHK4-46	7000	EHK7-46	7000
25 TON	EHK3-60	7000	EHK4-60	7000	EHK7-60	7000
	EHK3-75	7000	EHK4-75	7000	EHK7-75	7000

When using electric heat kit, use of the single point kit installed in the unit is required to meet UL requirements



ATTENTION INSTALLING PERSONNEL

Use only the heater kit specified for each model as dictated by the table above.

APPENDIX C UNIT DIMENSIONS

Model	A	B	C	D
15 Ton 20 Ton	133-1/2"	88-7/32"	50-9/32"	5-5/32"
25 Ton	133-1/2"	88-7/32"	53-9/32"	5-5/32"

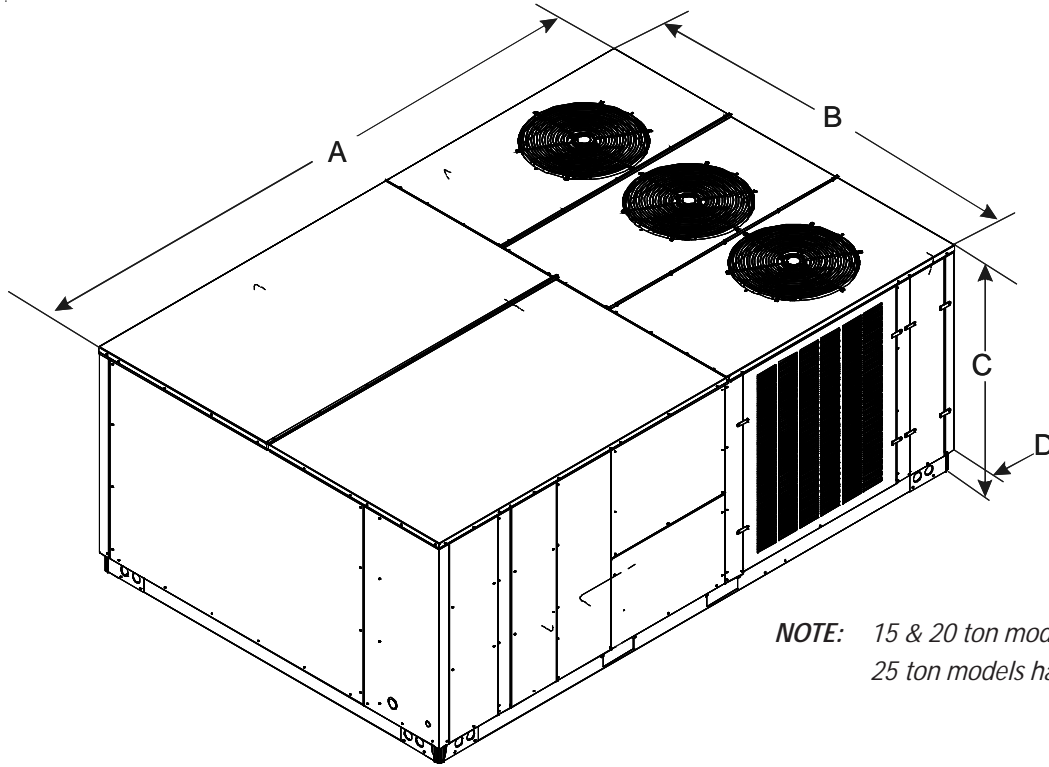

*NOTE: 15 & 20 ton models have 3 fans.
25 ton models have 2 fans.*

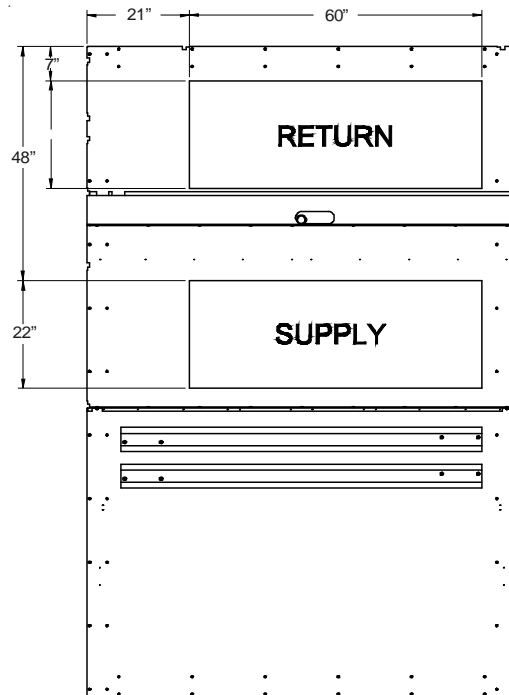

VERTICAL DISCHARGE (TOP VIEW)

APPENDIX D WIRING DIAGRAMS

DCC[180/240]***[230V, 460V, 575V]***



HIGH VOLTAGE!
DISCONNECT ALL POWER BEFORE SERVICING OR INSTALLING THIS UNIT. MULTIPLE POWER SOURCES MAY BE PRESENT. FAILURE TO DO SO MAY CAUSE PROPERTY DAMAGE, PERSONAL INJURY OR DEATH.

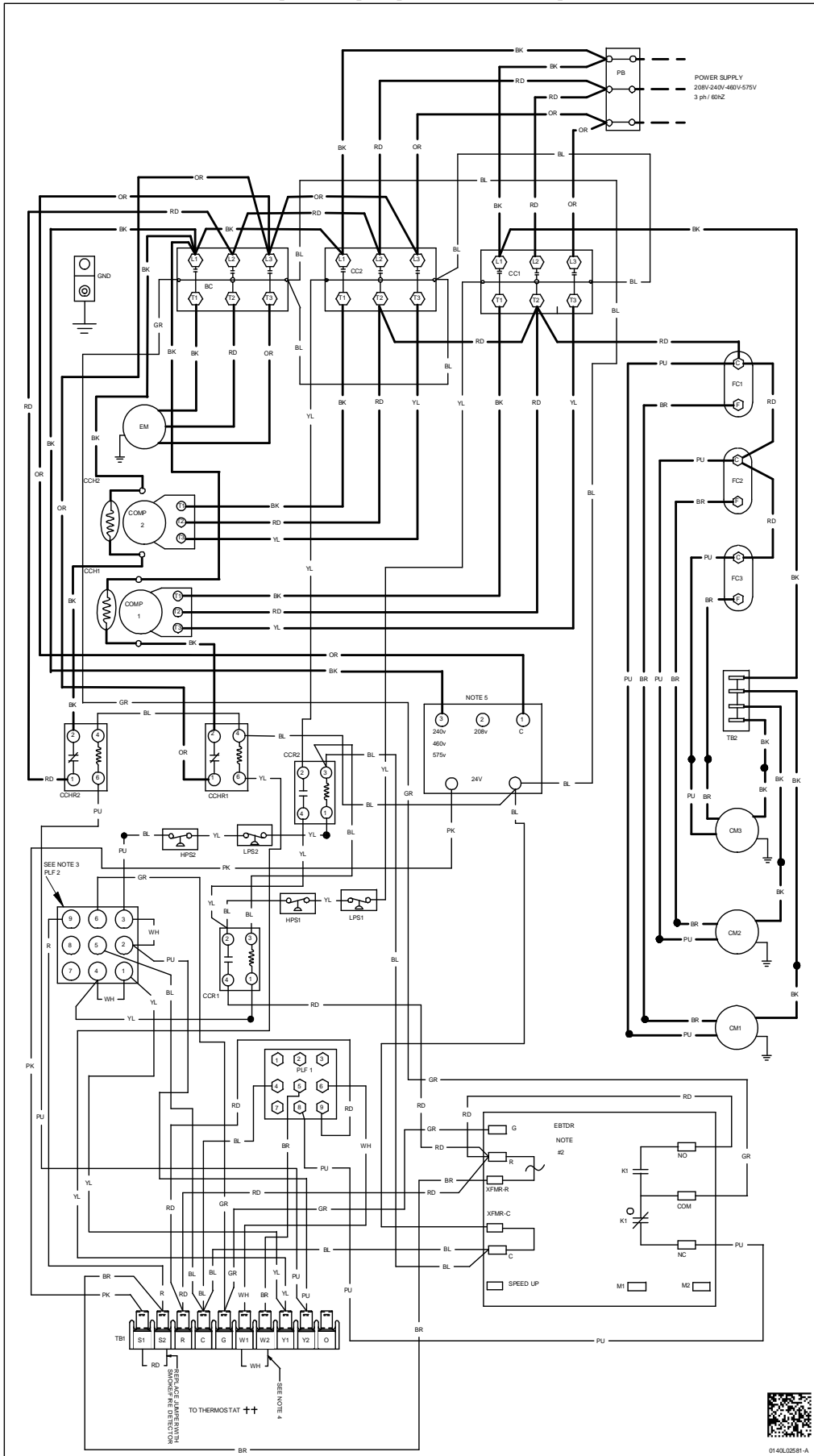

0140L02581-A

Wiring is subject to change. Always refer to the wiring diagram on the unit for the most up-to-date wiring.

HIGH VOLTAGE!
DISCONNECT ALL POWER BEFORE SERVICING OR INSTALLING THIS UNIT. MULTIPLE POWER SOURCES MAY BE PRESENT. FAILURE TO DO SO MAY CAUSE PROPERTY DAMAGE, PERSONAL INJURY OR DEATH.
WARNING

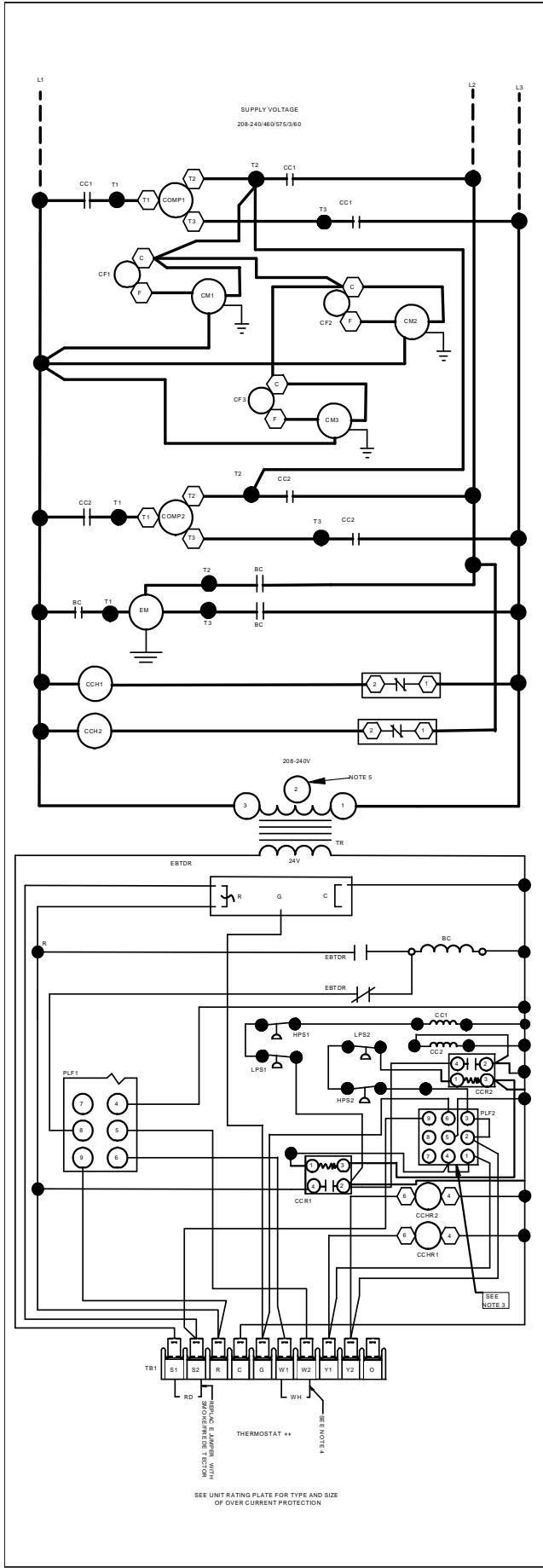

COMPONENT LEGEND

BC	BLOWER CONTACTOR
CC	COMPRESSOR CONTACTOR
CCH	CRANK CASE HEATER
CCHR	CRANK CASE HEATER RELAY
CCR	COMPRESSOR CONTACTOR RELAY
CM	CONDENSER MOTOR
CMR	CONDENSER MOTOR RELAY
COMP	COMPRESSOR
ECON	ECONOMIZER
EBTD	ELECTRONIC BLOWER TIME DELAY
EMR	EVAPORATOR MOTOR RELAY
R	RELAY
EM	EVAPORATOR MOTOR
FC	FAN CAPACITOR
GND	EQUIPMENT GROUND
HPS	HIGH PRESSURE SWITCH
LPS	LOW PRESSURE SWITCH
PB	POWER DISTRIBUTION BLOCK
PLF	FEMALE PLUG /CONNECTOR
TB1	TERMINAL BLOCK (24V SIGNAL)
TB2	TERMINAL BLOCK (L1)
TR	TRANSFORMER

- NOTES:**
- REPLACEMENT WIRE MUST BE SAME SIZE AND TYPE INSULATION AS ORIGINAL (AT LEAST 105°C). USE COPPER CONDUCTOR ONLY.
 - USE COPPER CONDUCTORS ONLY.
 - ECONOMIZER PLUG LOCATED IN THE RETURN AIR COMPARTMENT. REMOVE MALE PLUG, ATTACH FEMALE PLUG TO THE ECONOMIZER ACCESSORY.
 - FOR THIO STAGE OPERATION REMOVE W1 TO W2 WIRE JUMPER.
 - FOR 208V OPERATION MOVE BLACK WIRE FROM TERMINAL ① TO TERMINAL ② ON 240V TRANSFORMER.

FACTORY WIRING

— LINE VOLTAGE
 - - - LOW VOLTAGE

OPTIONAL HIGH VOLTAGE

— HIGH VOLTAGE
 - - - LOW VOLTAGE

WIRE CODE

BK	BLACK
BL	BLUE
BR	BROWN
GR	GREEN
OR	ORANGE
PK	PINK
PU	PURPLE
RD	RED
WH	WHITE
YL	YELLOW
YL/PK	YELLOW WITH PINK STRIP
BL/PK	BLUE WITH PINK STRIP

THERMOSTAT ++

FIELD WIRING

2 STAGE COOLING

W1	---	WH	---	W1
G	---	GR	---	G
R	---	RD	---	R
Y1	---	YL	---	Y1
Y2	---	PK	---	Y2
C	---	BL	---	C
O	---	OR	---	O
W2	---	BR	---	W2
TB1				STAT



0140L0252-A

Wiring is subject to change. Always refer to the wiring diagram on the unit for the most up-to-date wiring.

DCC[180/240]***[230V, 460V, 575V, 2 SPEED]***



HIGH VOLTAGE!
DISCONNECT ALL POWER BEFORE SERVICING OR INSTALLING THIS UNIT. MULTIPLE POWER SOURCES MAY BE PRESENT. FAILURE TO DO SO MAY CAUSE PROPERTY DAMAGE, PERSONAL INJURY OR DEATH.

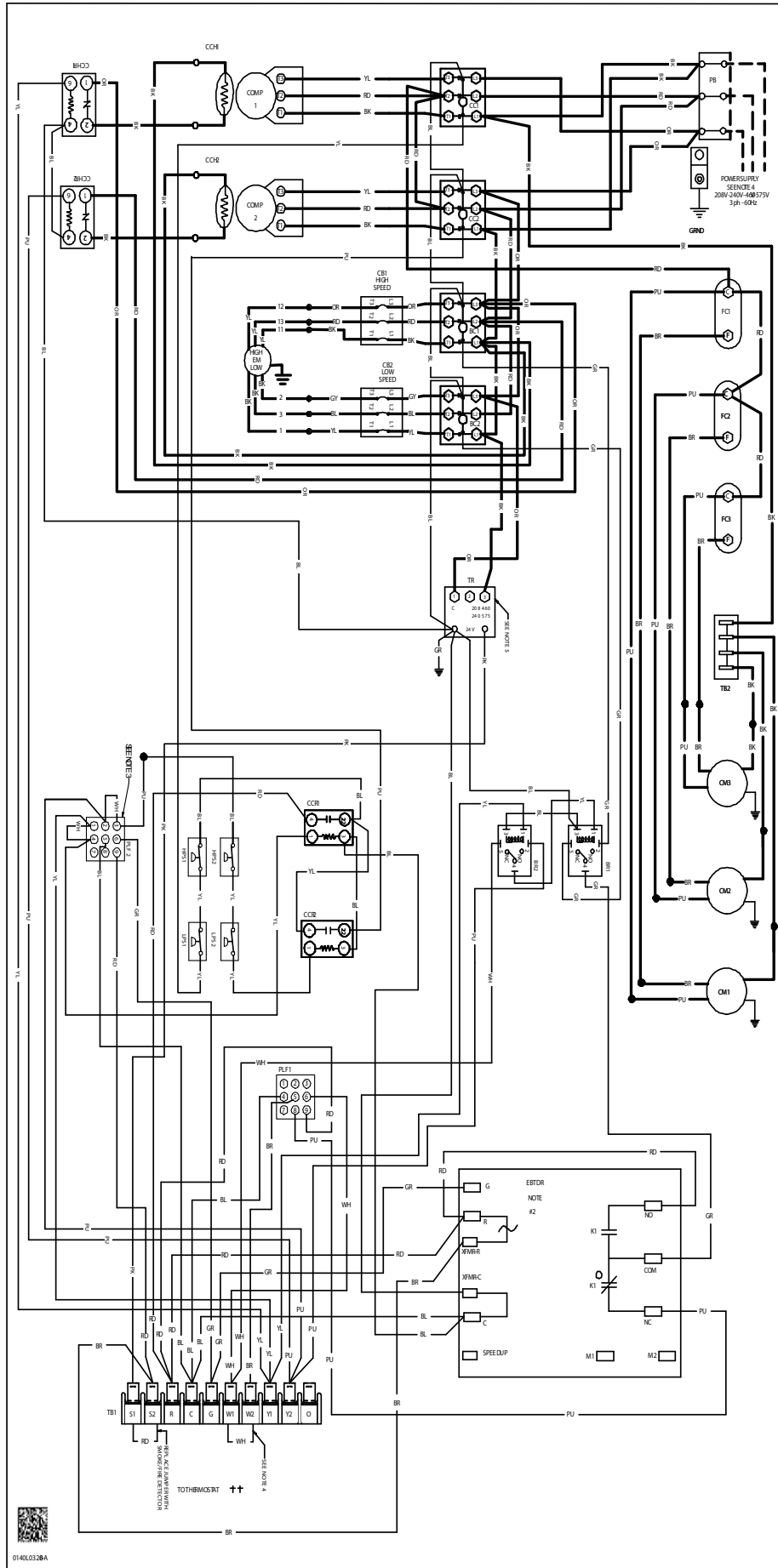

Wiring is subject to change. Always refer to the wiring diagram on the unit for the most up-to-date wiring.

DCC[180/240]***[230V, 460V, 575V, 2 SPEED]***

HIGH VOLTAGE!
 DISCONNECT ALL POWER BEFORE SERVICING OR INSTALLING THIS UNIT. MULTIPLE POWER SOURCES MAY BE PRESENT. FAILURE TO DO SO MAY CAUSE PROPERTY DAMAGE, PERSONAL INJURY OR DEATH.

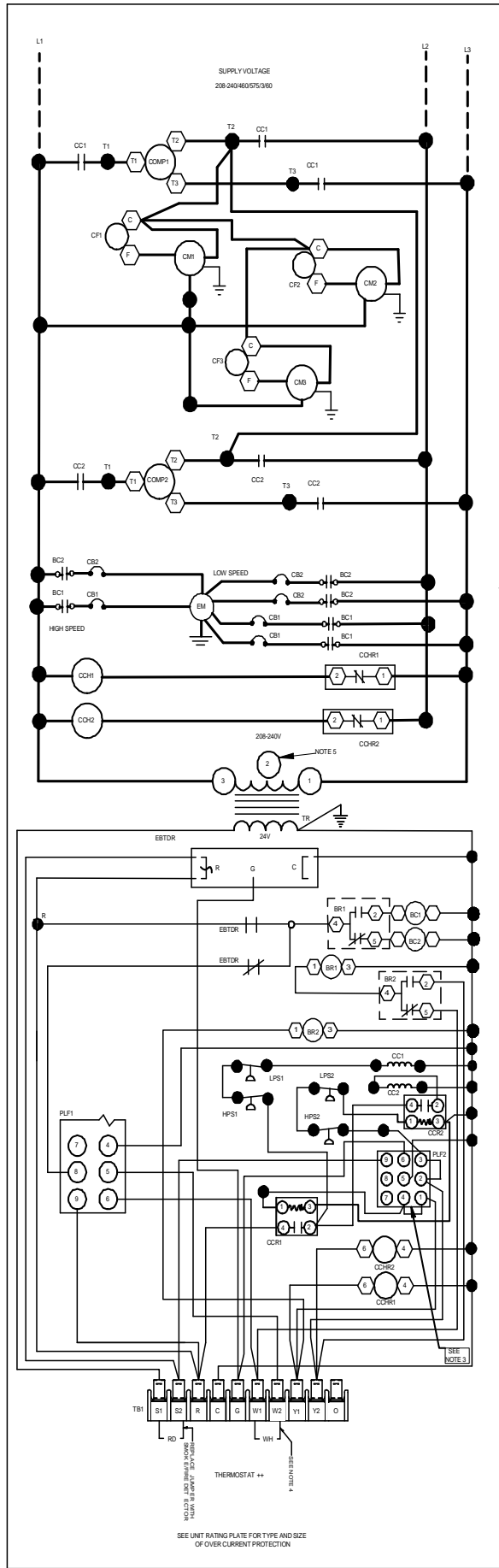

COMPONENT LEGEND

- BC BLOWER CONTACTOR
- BR BLOWER RELAY
- CC COMPRESSOR CONTACTOR
- CDH CRANK CASE HEATER
- CDHR CRANK CASE HEATER RELAY
- CCR COMPRESSOR CONTACTOR RELAY
- CM CONDENSER MOTOR
- CMR CONDENSER MOTOR RELAY
- COMP COMPRESSOR
- ECOM ECONOMIZER
- EBTD ELECTRONIC BLOWER TIME DELAY
- EMR EVAPORATOR MOTOR RELAY
- R RELAY
- EM EVAPORATOR MOTOR
- FC FAN CAPACITOR
- GND EQUIPMENT GROUND
- HPS HIGH PRESSURE SWITCH
- LPS LOW PRESSURE SWITCH
- PB POWER DISTRIBUTION BLOCK
- PLF FEMALE PLUG / CONNECTOR
- TB1 TERMINAL BLOCK (24V SIGNAL)
- TB2 TERMINAL BLOCK (L1)
- TR TRANSFORMER

NOTES:

1. REPLACEMENT WIRE MUST BE SAME SIZE AND TYPE INSULATION AS ORIGINAL (AT LEAST 185°C) USE COPPER CONDUCTOR ONLY.
2. USE COPPER CONDUCTORS ONLY
+ USE N.E.C. CLASS 2 WIRE
3. ECONOMIZER PLUG LOCATED IN THE RETURN AIR COMPARTMENT. REMOVE MALE PLUG, ATTACH FEMALE PLUG TO THE ECONOMIZER ACCESSORY.
4. FOR TWO STAGE OPERATION REMOVE W1 TO W2 WIRE JUMPER.
5. FOR 208V OPERATION MOVE BLACK WIRE FROM TERMINAL 1 TO TERMINAL 2 ON 240V TRANSFORMER.

FACTORY WIRING

- LINE VOLTAGE
- LOW VOLTAGE
- OPTIONAL HIGH VOLTAGE
- FIELD WIRING
- HIGH VOLTAGE
- LOW VOLTAGE

WIRE CODE

- BK BLACK
- BL BLUE
- BR BROWN
- GR GREEN
- OR ORANGE
- PK PINK
- PV PURPLE
- RD RED
- WH WHITE
- YL YELLOW
- YL/PK YELLOW WITH PINK STRIP
- BL/PK BLUE WITH PINK STRIP

THERMOSTAT ++
 FIELD WIRING
 2 STAGE COOLING

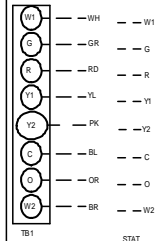

0140L02815A

Wiring is subject to change. Always refer to the wiring diagram on the unit for the most up-to-date wiring.

POWER DIAGRAM
DCC300, 230V

HIGH VOLTAGE!
 DISCONNECT ALL POWER BEFORE SERVICING OR INSTALLING THIS UNIT. MULTIPLE POWER SOURCES MAY BE PRESENT. FAILURE TO DO SO MAY CAUSE PROPERTY DAMAGE, PERSONAL INJURY OR DEATH.

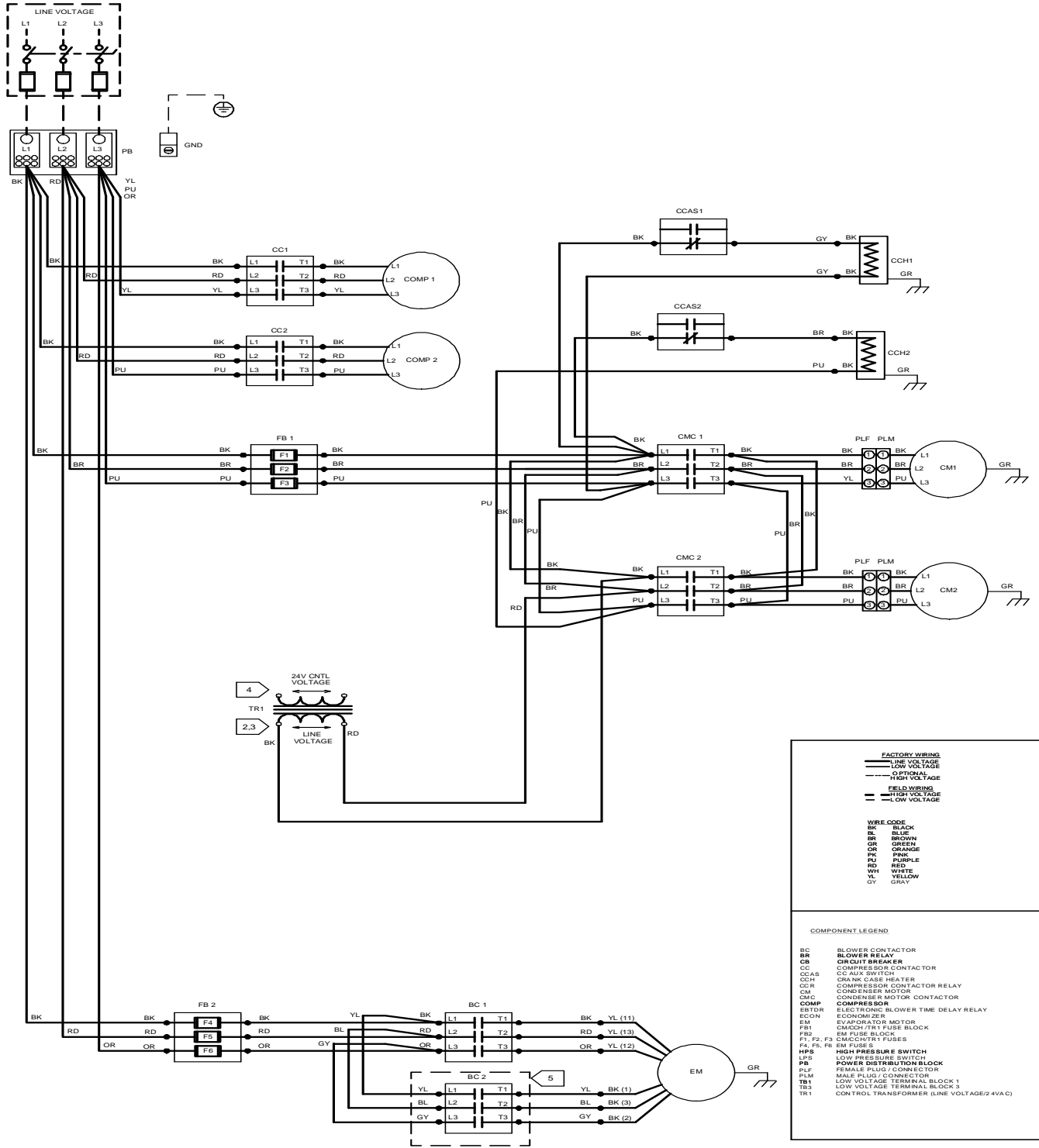

FACTORY WIRING	
—	LOW VOLTAGE
---	HIGH VOLTAGE
FIELD WIRING	
—	HIGH VOLTAGE
---	LOW VOLTAGE

WIRE CODE	
BK	BLACK
BL	BLUE
BR	BROWN
GR	GREEN
OR	ORANGE
PK	PINK
PU	PURPLE
RD	RED
WH	WHITE
YL	YELLOW
GY	GRAY

COMPONENT LEGEND	
BC	BLOWER CONTACTOR
BR	BLOWER RELAY
CB	CIRCUIT BREAKER
CC	COMPRESSOR CONTACTOR
CCAS	CRANK CASE HEATER
CC1	COMPRESSOR CONTACTOR RELAY
CM	CONDENSER MOTOR
CMC	CONDENSER MOTOR CONTACTOR
CM2	COMPRESSOR
EDTOR	ELECTRONIC BLOWER TIME DELAY RELAY
ECON	ECONOMIZER
EM	EVAPORATOR MOTOR
F1	CMCCH/TR1 FUSE BLOCK
F2	EM FUSE BLOCK
F3, F4, F5, F6	CMCCH/TR1 FUSES
HPS	HIGH PRESSURE SWITCH
LPS	LOW PRESSURE SWITCH
PE	POWER DISTRIBUTION BLOCK
PLF	FEMALE PLUG/CONNECTOR
PLM	MALE PLUG/CONNECTOR
TB1	LOW VOLTAGE TERMINAL BLOCK 1
TB3	LOW VOLTAGE TERMINAL BLOCK 3
TR1	CONTROL TRANSFORMER (LINE VOLTAGE/2 4VA)

- NOTES
- REPLACEMENT WIRE MUST BE SAME SIZE AND TYPE OF INSULATION AS ORIGINAL (USE COPPER CONDUCTORS ONLY).
 - THE CONTROL TRANSFORMER HAS MULTIPLE HIGH VOLTAGE TAPS.
 - ENSURE WIRE CONNECTIONS ARE CORRECT FOR UNIT SUPPLY VOLTAGE RATING.
 - 208/230V SUPPLY POWER UNITS ARE FACTORY CONNECTED TO THE CONTROL TRANSFORMER 240V TAP. MOVE WIRE CONNECTION FROM 240V TAP TO 208V TAP WHEN 208V POWER SUPPLY IS USED.
 - SEE CONTROL DIAGRAM 0140L04729/30 FOR CONTROL TRANSFORMER LOW VOLTAGE CONNECTIONS.
 - OPTIONAL: BC2 IS PRESENT ONLY WITH 2-SPEED EVAPORATOR MOTOR.
 - USE COPPER CONDUCTORS ONLY. UNIT TERMINALS ARE NOT DESIGNED FOR OTHER CONDUCTORS.
 - THE USE OF OTHER TYPE CONDUCTORS MAY CAUSE DAMAGE TO THE UNIT.
 - SEE ACCESSORY KIT LITERATURE FOR OPTIONAL ELEC HEAT AND CONVENIENCE OUTLET WIRING DIAGRAMS.

Wiring is subject to change. Always refer to the wiring diagram on the unit for the most up-to-date wiring.

CONTROLS DIAGRAM
DCC300, 1 SPD EM

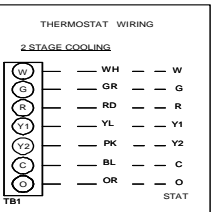
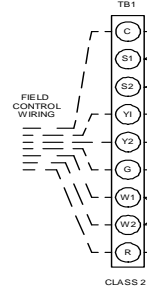
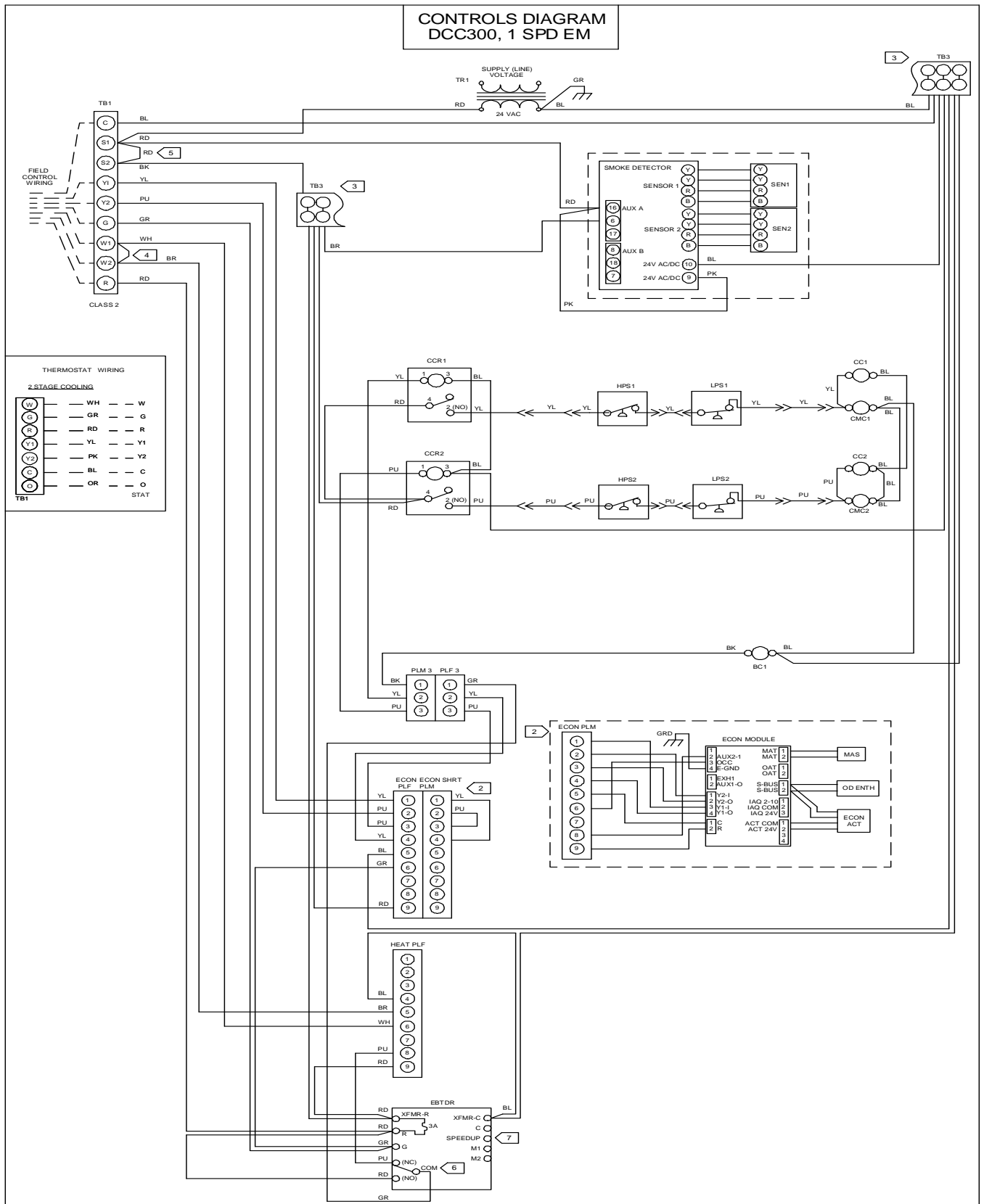

HIGH VOLTAGE!
 DISCONNECT ALL POWER BEFORE SERVICING OR INSTALLING THIS UNIT. MULTIPLE POWER SOURCES MAY BE PRESENT. FAILURE TO DO SO MAY CAUSE PROPERTY DAMAGE, PERSONAL INJURY OR DEATH.



- NOTES
1. REPLACEMENT WIRE MUST BE SAME SIZE AND TYPE OF INSULATION AS ORIGINAL (USE COPPER CONDUCTORS ONLY).
 2. IF OPTIONAL ECONOMIZER IS INSTALLED, REMOVE ECON SHRT PLM AND CONNECT ECON PLM TO ECON PLF.
 3. TB3 LOW VOLTAGE TERMINAL BLOCK. FOUR TERMINALS FOR 24VAC PWR (RED WIRE) AND SIX TERMINALS FOR 24VAC COM (BLUE WIRE).
 4. CONNECTIONS SHOWN ARE FOR 1-STAGE HEAT OPERATION. WHEN 2-STAGE OPERATION IS REQUIRED REMOVE JUMPER WIRE CONNECTING W2 TO W1 ON TB1.
 5. IF OPTIONAL SMOKE DETECTOR IS INSTALLED, REMOVE JUMPER WIRE CONNECTING S1 TO S2 ON TB1.
 6. EBDTR RELAY ENERGIZES 7 SEC AFTER 24VAC IS APPLIED TO "G". THE RELAY DE-ENERGIZES 65 SEC AFTER 24VAC IS REMOVED FROM "G".
 7. EBDTR RELAY DELAYS WILL DECREASE TO APPROX 3-5 SEC WHEN "SPEEDUP" IS SHORTED TO "C".

CNTL DIAG
DCC300***[3,4,7]B
0140L04730-A

Wiring is subject to change. Always refer to the wiring diagram on the unit for the most up-to-date wiring.



Start-up Checklist

**Store in job file*

Date: _____ Location: _____
Model Number: _____
Serial Number: _____
Technician: _____ Unit #: _____

Pre Start-Up

(Check each item as completed)

- Verify all packaging material has been removed.
- Remove all shipping brackets per installation instructions.
- Verify the job site voltage agrees with the unit serial plate.
- Verify condensate connection is installed per installation instructions.
- Verify proper clearance around the unit for safety, service, maintenance and proper unit operation.
- Verify proper weatherproofing of all ductwork, roof curbs and electrical connections.
- Check that the flue screen is in place.
- Check gas piping for leaks.
- Verify gas pressure to the unit is within the range specified on the serial plate.
- Check to ensure that all fans, pulleys and wheels are secure.
- Check for proper belt tension and alignment per installation instructions.
- Check refrigerant piping for rubbing and leaks. *Repair if necessary.*
- Check unit wiring to ensure it is not in contact with refrigerant piping or sharp metal edges.
- Check all electrical connections and terminals. *Tighten as needed.*
- Verify that the crankcase heaters have been energized for 24 hours.
- Verify the scroll compressor(s) are rotating in the right direction.
- Verify all accessories are installed and operating correctly.
- Check filters and replace if necessary.
- Verify the installation of the thermostat.



Start-up Checklist

Start-Up
(Insert the values as each item is completed.)

ELECTRICAL

Supply Voltage	L1 - L2	_____	L2 - L3	_____	L3 - L1	_____
Circuit 1 Compressor Amps	L1	_____	L2	_____	L3	_____
Circuit 2 Compressor Amps	L1	_____	L2	_____	L3	_____
Blower Amps	L1	_____	L2	_____	L3	_____
Condenser Fan Amps	Fan 1	_____	Fan 2	_____	Fan 3	_____

BLOWER EXTERNAL STATIC PRESSURE

Return Air Static Pressure	_____	IN. W.C.
Supply Air Static Pressure	_____	IN. W.C.
Total External Static Pressure	_____	IN. W.C.
Blower Wheel RPM	_____	RPM

TEMPERATURES

Outdoor Air Temperature	_____	DB	_____	WB
Return Air Temperature	_____	DB	_____	WB
Cooling Supply Air Temperature	_____	DB	_____	WB
Heating Supply Air Temperature	_____	DB	_____	

PRESSURES

Gas Inlet Pressure	_____	IN. W.C.		
Gas Manifold Pressure	_____	IN. W.C. (Low Fire)	_____	IN. W.C. (High Fire)
Suction Circuit 1	_____	PSIG	_____	°F
Superheat (Orifice System)			_____	°F
Suction Circuit 2	_____	PSIG	_____	°F
Superheat (Orifice System)			_____	°F
Discharge Circuit 1	_____	PSIG	_____	°F
Subcooling (TXV System)			_____	°F
Discharge Circuit 2	_____	PSIG	_____	°F
Subcooling (TXV System)			_____	°F

(HEAT PUMP ONLY)

Suction Circuit 1	_____	PSIG	_____	°F
Suction Circuit 2	_____	PSIG	_____	°F
Discharge Circuit 1	_____	PSIG	_____	°F
Discharge Circuit 2	_____	PSIG	_____	°F

Our continuing commitment to quality products may mean a change in specifications without notice.

© 2013, 2015 **DAIKIN COMPANY, L.P.**
5151 San Felipe St., Suite 500, Houston, TX 77056
www.daikincomfort.com