

# INSTALLATION AND OPERATION INSTRUCTIONS



## CONTENTS

SECTION 1 INSTALLATION INSTRUCTIONS

SECTION 2 THERMOSTAT INSTRUCTIONS

SECTION 3 USER'S INFORMATION MANUAL

### ▲ WARNING

THESE INSTRUCTIONS ARE INTENDED AS AN AID TO QUALIFIED SERVICE PERSONNEL FOR PROPER INSTALLATION, ADJUSTMENT AND OPERATION OF THIS UNIT. READ THESE INSTRUCTIONS THOROUGHLY BEFORE ATTEMPTING INSTALLATION OR OPERATION. FAILURE TO FOLLOW THESE INSTRUCTIONS MAY RESULT IN IMPROPER INSTALLATION, ADJUSTMENT, SERVICE OR MAINTENANCE, POSSIBLY RESULTING IN FIRE, ELECTRICAL SHOCK, CARBON MONOXIDE POISONING, EXPLOSION, PROPERTY DAMAGE, PERSONAL INJURY OR DEATH.

### INSTALLER:

USE THE INFORMATION IN THIS BOOKLET TO INSTALL THE FURNACE AND THE FURNACE CONTROLLER. LOCATE THIS BOOKLET ADJACENT TO THE UNIT AFTER INSTALLATION.

### USER:

KEEP THIS BOOKLET OF INFORMATION FOR FUTURE REFERENCE.





# INSTALLATION INSTRUCTIONS



# INSTALLATION INSTRUCTIONS

## FOR (-)GFD UPFLOW & (-)GGD DOWNFLOW HIGH EFFICIENCY MODULATING CONDENSING GAS FURNACES



**RECOGNIZE THIS SYMBOL AS AN INDICATION OF IMPORTANT SAFETY INFORMATION!**

### ▲ WARNING

IF THE INFORMATION IN THESE INSTRUCTIONS IS NOT FOLLOWED EXACTLY, A FIRE OR EXPLOSION MAY RESULT, CAUSING PROPERTY DAMAGE, PERSONAL INJURY OR DEATH.

### ▲ WARNING

THESE INSTRUCTIONS ARE INTENDED AS AN AID TO QUALIFIED SERVICE PERSONNEL FOR PROPER INSTALLATION, ADJUSTMENT AND OPERATION OF THIS UNIT. READ THESE INSTRUCTIONS THOROUGHLY BEFORE ATTEMPTING INSTALLATION OR OPERATION. FAILURE TO FOLLOW THESE INSTRUCTIONS MAY RESULT IN IMPROPER INSTALLATION, ADJUSTMENT, SERVICE OR MAINTENANCE, POSSIBLY RESULTING IN FIRE, ELECTRICAL SHOCK, CARBON MONOXIDE POISONING, EXPLOSION, PROPERTY DAMAGE, PERSONAL INJURY OR DEATH.

### ▲ WARNING

PROPOSITION 65 WARNING: THIS PRODUCT CONTAINS CHEMICALS KNOWN TO THE STATE OF CALIFORNIA TO CAUSE CANCER, BIRTH DEFECTS OR OTHER REPRODUCTIVE HARM.

### ▲ WARNING

- Do not store or use gasoline or other flammable vapors and liquids, or other combustible materials in the vicinity of this or any other appliance.
- WHAT TO DO IF YOU SMELL GAS
  - Do not try to light any appliance.
  - Do not touch any electrical switch; do not use any phone in your building.
  - Immediately call your gas supplier from a neighbor's phone. Follow the gas supplier's instructions.
  - If you cannot reach your gas supplier, call the fire department.
  - Do not return to your home until authorized by the gas supplier or fire department.
- DO NOT RELY ON SMELL ALONE TO DETECT LEAKS. DUE TO VARIOUS FACTORS, YOU MAY NOT BE ABLE TO SMELL FUEL GASES.
  - U.L. recognized fuel gas and CO detectors are recommended in all applications, and their installation should be in accordance with the manufacturer's recommendations and/or local laws, rules, regulations, or customs.
- Improper installation, adjustment, alteration, service or maintenance can cause injury, property damage or death. Refer to this manual. Installation and service must be performed by a qualified installer, service agency or the gas supplier. In the commonwealth of Massachusetts, installation must be performed by a licensed plumber or gas fitter for appropriate fuel.



**ISO 9002**

Certificate Number: 30164

**DO NOT DESTROY THIS MANUAL. PLEASE READ CAREFULLY AND KEEP IN A SAFE PLACE FOR FUTURE REFERENCE BY A SERVICEMAN.**

# CONTENTS

Safety Information .....	3
Installation Check List .....	4
General Information .....	5
Location Requirements and Considerations.....	6
Venting and Combustion Air Piping .....	14
Non-Direct Vent Pipe Installation .....	16
Direct Vent Pipe Installation .....	20
Condensate Drain/Optional Neutralizer .....	29
Gas Supply and Piping .....	33
Electrical Wiring.....	38
Accessories .....	41
Installation w/Heat Pump Systems .....	45
High Altitude Installations .....	50
Installation with Premium/High Efficiency Cooling Systems.....	53
Integrated Furnace Control .....	54
Start-Up Procedures .....	57
Maintenance.....	60
Troubleshooting.....	63
Wiring Diagram.....	71

Installation Instructions are updated on a regular basis. This is done as product changes occur or if new information becomes available. In this publication, an arrow ► denotes changes from the previous edition or additional new material.

---

**IMPORTANT:** To insure proper installation and operation of this product, completely read all instructions prior to attempting to assemble, install, operate, maintain or repair this product. Upon unpacking of THE furnace, inspect all parts for damage prior to installation and start-up.

---

# SAFETY INFORMATION

## ▲ WARNING

USE ONLY WITH TYPE OF GAS APPROVED FOR THIS FURNACE. REFER TO THE FURNACE RATING PLATE.

## ▲ WARNING

INSTALL THIS FURNACE ONLY IN A LOCATION AND POSITION AS SPECIFIED IN THE LOCATION REQUIREMENTS AND CONSIDERATIONS SECTION OF THESE INSTRUCTIONS. PROVIDE ADEQUATE COMBUSTION AND VENTILATION AIR TO THE FURNACE SPACE AS SPECIFIED IN THE VENTING SECTION OF THESE INSTRUCTIONS.

## ▲ WARNING

PROVIDE ADEQUATE COMBUSTION AND VENTILATION AIR TO THE FURNACE SPACE AS SPECIFIED IN THE COMBUSTION AND VENTILATION AIR SECTION OF THESE INSTRUCTIONS.

## ▲ WARNING

COMBUSTION PRODUCTS MUST BE DISCHARGED OUTDOORS. CONNECT THIS FURNACE TO AN APPROVED VENT SYSTEM ONLY, AS SPECIFIED IN VENT PIPE INSTALLATION SECTION OF THESE INSTRUCTIONS.

## ▲ WARNING

DO NOT INSTALL THIS FURNACE IN A MOBILE HOME!! THIS FURNACE IS NOT APPROVED FOR INSTALLATION IN A MOBILE HOME. DOING SO COULD CAUSE FIRE, PROPERTY DAMAGE, PERSONAL INJURY OR DEATH.

## ▲ WARNING

NEVER TEST FOR GAS LEAKS WITH AN OPEN FLAME. USE A COMMERCIALY AVAILABLE SOAP SOLUTION MADE SPECIFICALLY FOR THE DETECTION OF LEAKS TO CHECK ALL CONNECTIONS, AS SPECIFIED IN GAS SUPPLY AND PIPING SECTION OF THESE INSTRUCTIONS.

## ▲ WARNING

ALWAYS INSTALL FURNACE TO OPERATE WITHIN THE FURNACE'S INTENDED TEMPERATURE-RISE RANGE WITH A DUCT SYSTEM WHICH HAS AN EXTERNAL STATIC PRESSURE WITHIN THE ALLOWABLE RANGE, AS SPECIFIED IN DUCTING SECTION OF THESE INSTRUCTIONS. SEE ALSO FURNACE RATING PLATE.

## ▲ WARNING

WHEN A FURNACE IS INSTALLED SO THAT SUPPLY DUCTS CARRY AIR CIRCULATED BY THE FURNACE TO AREAS OUTSIDE THE SPACE CONTAINING THE FURNACE, THE RETURN AIR SHALL ALSO BE HANDLED BY DUCT(S) SEALED TO THE FURNACE CASING AND TERMINATING OUTSIDE THE SPACE CONTAINING THE FURNACE.

## ▲ WARNING

WHEN THIS FURNACE IS INSTALLED IN A RESIDENTIAL GARAGE, IT MUST BE INSTALLED SO THE BURNERS AND IGNITION SOURCE ARE LOCATED NO LESS THAN 18 INCHES ABOVE THE FLOOR. THIS IS TO REDUCE THE RISK OF IGNITING FLAMMABLE VAPORS WHICH MAY BE PRESENT IN A GARAGE. ALSO, THE FURNACE MUST BE LOCATED OR PROTECTED TO AVOID PHYSICAL DAMAGE BY VEHICLES. FAILURE TO FOLLOW THESE WARNINGS CAN CAUSE A FIRE OR EXPLOSION, RESULTING IN PROPERTY DAMAGE, PERSONAL INJURY OR DEATH.

## ▲ WARNING

USE OF THIS FURNACE IS ALLOWED DURING CONSTRUCTION IF THE FOLLOWING TEMPORARY INSTALLATION REQUIREMENTS ARE MET. INSTALLATION MUST COMPLY WITH ALL INSTALLATION INSTRUCTIONS INCLUDING:

- PROPER VENT INSTALLATION;
- FURNACE OPERATING UNDER THERMOSTATIC CONTROL;
- RETURN AIR DUCT SEALED TO THE FURNACE;
- AIR FILTERS IN PLACE;
- SET FURNACE INPUT RATE AND TEMPERATURE RISE PER RATING PLATE MARKING;
- MEANS FOR PROVIDING OUTDOOR AIR REQUIRED FOR COMBUSTION;
- RETURN AIR TEMPERATURE MAINTAINED BETWEEN 55°F (13°C) AND 80°F (27°C); AND;
- CLEAN FURNACE, DUCT WORK AND COMPONENTS UPON SUBSTANTIAL COMPLETION OF THE CONSTRUCTION PROCESS, AND VERIFY FURNACE OPERATING CONDITIONS INCLUDING IGNITION, INPUT RATE, TEMPERATURE RISE AND VENTING, ACCORDING TO THE INSTRUCTIONS.

# INSTALLATION CHECK LIST

REFER TO INSTALLATION INSTRUCTIONS

## GAS SUPPLY

- \_\_\_\_\_ Adequate pipe size
- \_\_\_\_\_ Correct supply pressure (during furnace operation)
- \_\_\_\_\_ Manifold pressure
- \_\_\_\_\_ No gas leaks

## ELECTRICAL

- \_\_\_\_\_ 115 V.A.C. supply (Single Circuit)
- \_\_\_\_\_ Polarity observed
- \_\_\_\_\_ Furnace properly grounded (Earth ground)
- \_\_\_\_\_ Adequate wire size

## FURNACE INSTALLATION

- \_\_\_\_\_ Adequate clearance to combustibles
- \_\_\_\_\_ Adequate clearance for service (at front)

## DUCT STATIC PRESSURE

- \_\_\_\_\_ in. w.c. on heating speed
- \_\_\_\_\_ in. w.c. on cooling speed
- \_\_\_\_\_ Air temperature rise

## CONDENSATE LINE

- \_\_\_\_\_ Trap filled with water
- \_\_\_\_\_ Vented
- \_\_\_\_\_ Sloped toward drain
- \_\_\_\_\_ Condensate drain line hoses connected and clamped
- \_\_\_\_\_ Freeze protection (if necessary)
- \_\_\_\_\_ Neutralizer (if needed)

## VENTING – DIRECT VENT

- \_\_\_\_\_ in. diameter – intake pipe
- \_\_\_\_\_ in. diameter – exhaust pipe
- \_\_\_\_\_ ft. of pipe – intake air
- \_\_\_\_\_ no. of elbows – intake air
- \_\_\_\_\_ ft. of pipe – exhaust pipe
- \_\_\_\_\_ no. of elbows – exhaust pipe

## TERMINATIONS – DIRECT VENT

### VERTICAL

- \_\_\_\_\_ Intake – 12" min. above roof/snow level
- \_\_\_\_\_ Correct relationship – exhaust to intake

### VERTICAL – CONCENTRIC (RXGY-E03)

- \_\_\_\_\_ Intake – 12" min. above roof/snow level

### HORIZONTAL – STANDARD (RXGY-D02, -D03)

- \_\_\_\_\_ Correct relationship – exhaust to intake
- \_\_\_\_\_ 12" min. above grade/snow level

### HORIZONTAL – ALTERNATE (RXGY-D02, -D03 OR -D04)

- \_\_\_\_\_ Correct relationship – exhaust to intake
- \_\_\_\_\_ Above anticipated snow level

### HORIZONTAL – CONCENTRIC (RXGY-E03)

- \_\_\_\_\_ 12" min. above grade/snow level

- \_\_\_\_\_ Intake "Y" rotated above center

- \_\_\_\_\_ Exhaust sloped toward furnace

## VENTING – NON-DIRECT VENT (VERTICAL ONLY)

- \_\_\_\_\_ in. diameter – exhaust pipe
- \_\_\_\_\_ ft. of pipe – exhaust
- \_\_\_\_\_ no. of elbows

## TERMINATION – NON-DIRECT VENT (VERTICAL ONLY)

- \_\_\_\_\_ 12" min. above roof/snow level

\_\_\_\_\_ Model #

\_\_\_\_\_ Serial #

\_\_\_\_\_ Date of installation



## GENERAL INFORMATION

The (-)GFD and (-)GGD series furnaces are design-certified by CSA for use with natural and L.P. gases as follows:

- As direct vent, central forced air furnaces with all combustion air supplied directly to the furnace burners through a special air intake system outlined in these instructions.
- As non-direct, central forced air furnace taking combustion air from the installation area or using air ducted from the outside.

Install this furnace in accordance with the American National Standard Z223.1 – latest edition entitled “National Fuel Gas Code” (NFPA54, 90A and 90B) and requirements or codes of the local utilities or other authorities having jurisdiction. This is available from the following:

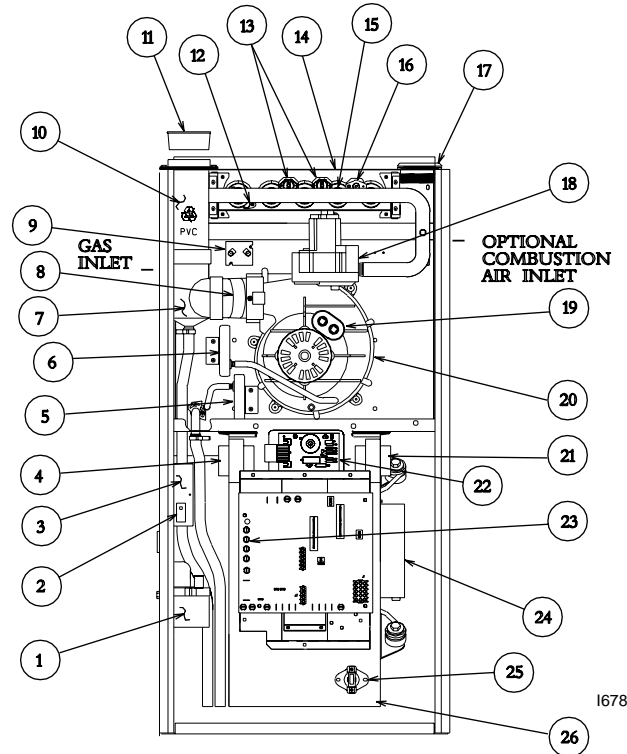
National Fire Protection Association, Inc.  
Batterymarch Park  
Quincy, MA 02269

CSA International - U.S.  
8501 East Pleasant Valley Road  
Cleveland, Ohio, 44131

Canadian installations must be installed in accordance with CSA, local installation codes and authorities having jurisdiction. CSA is available from:

CSA International - Canada  
178 Rexdale Blvd.  
Etobicoke (Toronto), Ontario,  
Canada M9W-1R3

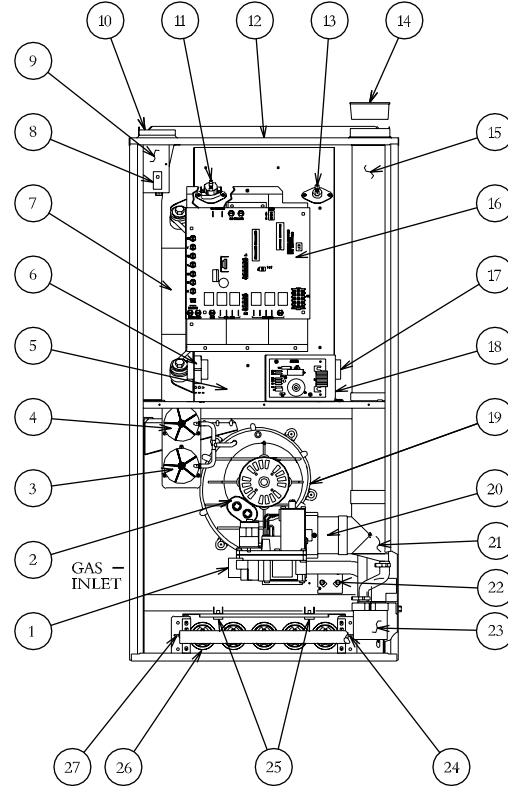
**FIGURE 1**  
UPFLOW FURNACE



1678

ITEM NO.	PART NAME	ITEM NO.	PART NAME
1	CONDENSATE TRAP	14	TOP PLATE
2	DOOR SWITCH	15	BURNER
3	JUNCTION BOX	16	IGNITER
4	TRANSFORMER	17	COMBUSTION AIR INLET
5	LOW PRESSURE SWITCH	18	GAS VALVE
6	HIGH PRESSURE SWITCH	19	CAPACITOR
7	EXHAUST TRANSITION	20	INDUCED DRAFT BLOWER
8	CONNECTOR	21	POWER FACTOR CHOKE
9	MAIN LIMIT	22	IGNITION CONTROL
10	EXHAUST AIR PIPE	23	INTEGRATED FURNACE CONTROL
11	VENT CAP PLUG	24	BLOWER MOTOR
12	FLAME SENSOR	25	R/A SENSOR
13	OVERTEMPERATURE SWITCH	26	BLOWER HOUSING

**FIGURE 2**  
DOWNFLOW/HORIZONTAL FURNACE



ITEM NO.	PART NAME	ITEM NO.	PART NAME
1	GAS VALVE	14	VENT CAP PLUG
2	CAPACITOR	15	EXHAUST AIR PIPE
3	LOW PRESSURE SWITCH	16	INTEGRATED FURNACE CONTROL
4	HIGH PRESSURE SWITCH	17	TRANSFORMER
5	BLOWER HOUSING	18	IGNITION CONTROL
6	POWER FACTOR CHOKE	19	INDUCED DRAFT BLOWER
7	BLOWER MOTOR	20	CONNECTOR
8	DOOR SWITCH	21	EXHAUST TRANSITION
9	JUNCTION BOX	22	MAIN LIMIT
10	COMBUSTION AIR INLET	23	CONDENSATE TRAP
11	HALC	24	IGNITER
12	TOP PLATE	25	OVERTEMPERATURE SWITCH
13	RETURN AIR SENSOR	26	BURNER
		27	FLAME SENSOR

# LOCATION REQUIREMENTS AND CONSIDERATIONS

## GENERAL INFORMATION

### ▲ CAUTION

DO NOT USE THIS FURNACE DURING CONSTRUCTION IF AIR LADEN CORROSIVE COMPOUNDS ARE PRESENT SUCH AS CHLORINE AND FLUORINE. OTHERWISE, PROVISIONS MUST BE TAKEN TO PROVIDE CLEAN, UNCONTAMINATED COMBUSTION AND VENTILATION AIR TO THE FURNACE. FURNACE COMBUSTION AND VENTILATION AIR CONTAMINATED WITH THESE COMPOUNDS FORMS ACIDS DURING COMBUSTION WHICH CORRODES THE HEAT EXCHANGER AND COMPONENT PARTS. SOME OF THESE CONTAMINANTS ARE FOUND IN, BUT NOT LIMITED TO, PANELING, DRY WALL, ADHESIVES, PAINTS, STAINS, VARNISHES, SEALERS, AND MASONRY CLEANING MATERIALS.

### ▲ WARNING

DO NOT INSTALL THIS FURNACE IN A MOBILE HOME!! THIS FURNACE IS NOT APPROVED FOR INSTALLATION IN A MOBILE HOME. DOING SO COULD CAUSE FIRE, PROPERTY DAMAGE, PERSONAL INJURY OR DEATH.

### ▲ WARNING

WHEN THIS FURNACE IS INSTALLED IN A RESIDENTIAL GARAGE, IT MUST BE INSTALLED SO THE BURNERS AND IGNITION SOURCE ARE LOCATED NO LESS THAN 18 INCHES ABOVE THE FLOOR. THIS IS TO REDUCE THE RISK OF IGNITING FLAMMABLE VAPORS WHICH MAY BE PRESENT IN A GARAGE. ALSO, THE FURNACE MUST BE LOCATED OR PROTECTED TO AVOID PHYSICAL DAMAGE BY VEHICLES. FAILURE TO FOLLOW THESE WARNINGS CAN CAUSE A FIRE OR EXPLOSION, RESULTING IN PROPERTY DAMAGE, PERSONAL INJURY OR DEATH.

1. **IMPORTANT:** When installing the -GGD furnace in the horizontal configuration, a special kit must be used to convert the furnace for horizontal installation. The necessary kits are listed here.

FURNACE MODEL	HORIZONTAL CONVERSION KIT
---------------	---------------------------

(-)GGD-06	..... RXGY-G01
(-)GGD-07	..... RXGY-G02
(-)GGD-09	..... RXGY-G03
(-)GGD-10	..... RXGY-G04
(-)GGD-12	..... RXGY-G05

2. **IMPORTANT:** If installing the unit over a finished ceiling or living area, be certain to install an auxiliary condensate drain pan under the entire unit. Extend this auxiliary drain pan under any evaporator coil installed with the furnace and the open portion of the condensate drain assembly. See "Condensate Drain/Neutralizer" section for more details.
3. **IMPORTANT:** If using a cooling evaporator coil with this furnace. Be sure the air passes over the heat exchanger before passing over the cooling coil. The cooled air passing over the warm ambient air inside the heat exchanger tubes can cause condensation inside the tubes resulting in corrosion and eventual failure.
4. **IMPORTANT:** Install the furnace level. If it is not level, condensate cannot drain properly, possibly causing furnace shut down.

**NOTE:** These furnaces are approved for installation in attics, as well as alcoves, utility rooms, closets and crawlspaces. Make provisions to prevent freezing of condensate.

5. **IMPORTANT:** If this furnace is installed in a garage, attic or any other unconditioned space, a self-regulating heat tape must be installed around the condensate

trap and along the entire length of the condensate drain in the unconditioned space.

The heat tape should meet the following requirements:

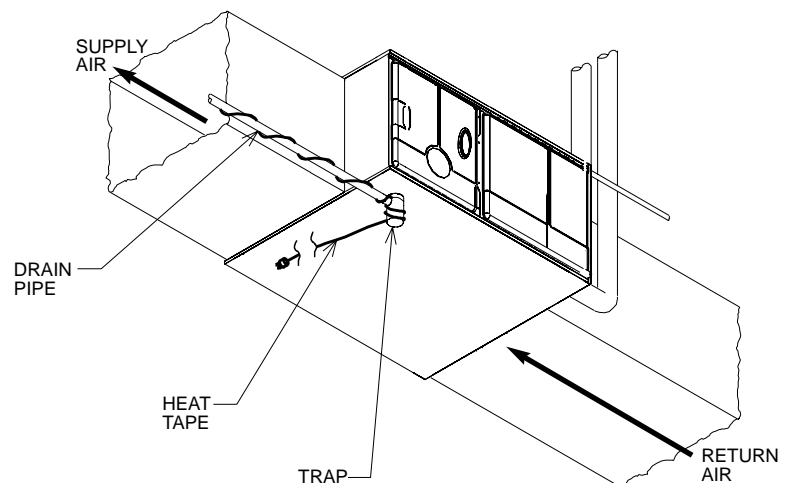
- a. The heat tape must be UL listed.
  - b. Install the heat tape per the manufacturer's instructions for the entire length of drain pipe in the unconditioned space.
  - c. The heat tape should be rated at 3 or 5 watts per foot at 120V.
6. **IMPORTANT:** If installing in a utility room, be sure the door is wide enough to:
    - a. allow the largest part of the furnace to pass; or
    - b. allow any other appliance (such as a water heater) to pass.
  7. Install the furnace level and plumb. If it is not level, condensate cannot drain properly, possibly causing furnace to shut down.

**IMPORTANT:** Do not attempt to twin the modulating furnace. The characteristics of the ecm2 blower motor preclude twinning applications.

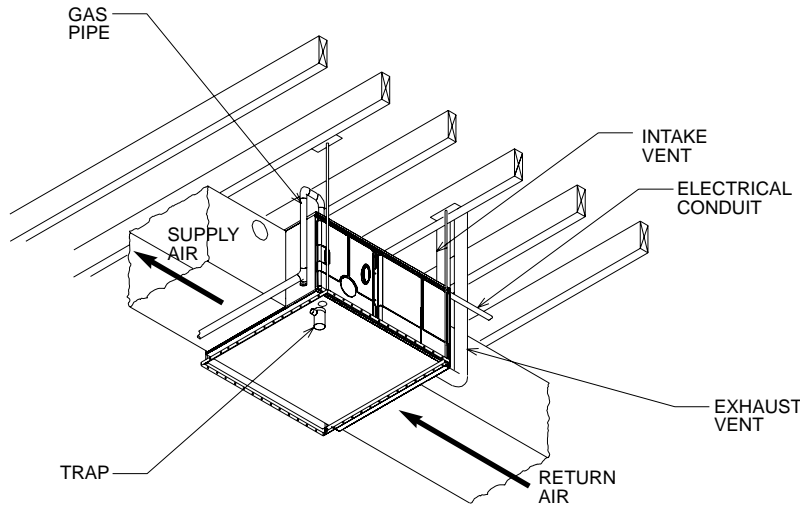
### ▲ CAUTION

LOCATE AND REMOVE THE SHIPPING BRACKET FROM THE SIDE OF THE BLOWER HOUSING BEFORE OPERATING UNIT. SEE FIGURE 5.

FIGURE 3  
HORIZONTAL FURNACE WITH HEAT TAPE ON CONDENSATE TRAP



**FIGURE 4**  
HORIZONTAL FURNACE INSTALLED W/SUPPORT BRACKETS

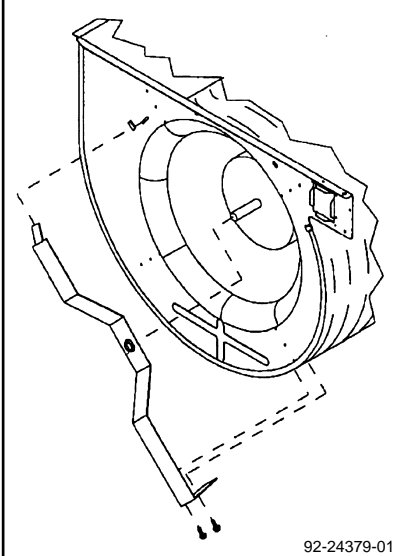


**▲ CAUTION**

THIS FURNACE IS NOT APPROVED OR RECOMMENDED FOR INSTALLATION ON ITS BACK, WITH ACCESS DOORS FACING UPWARDS, OR WITH SUPPLY AIR DISCHARGING TO THE RIGHT HAND SIDE WHEN FACING THE FRONT OF THE FURNACE.

SEE FIGURES 3 AND 4 FOR PROPER INSTALLATION OF HORIZONTAL MODELS.

**FIGURE 5**  
REMOVING SHIPPING BRACKET



**CLEARANCE - ACCESSIBILITY**

**IMPORTANT:** When installing the -GGD furnace in the horizontal configuration, a special kit must be used to convert the furnace for horizontal installation. The necessary kits are listed here.

**FURNACE MODEL**

(-)GGD-06	.....	RXGY-G01
(-)GGD-07	.....	RXGY-G02
(-)GGD-09	.....	RXGY-G03
(-)GGD-10	.....	RXGY-G04
(-)GGD-12	.....	RXGY-G05

**HORIZONTAL CONVERSION KIT**

The design of forced air furnaces with models as listed in the tables under Figures 6, 7 and 8 are certified by CSA Laboratories for the clearances to combustible materials shown in inches.

See name/rating plate and clearance label for specific model number and clearance information.

Service clearance of at least 24 inches is recommended in front of all furnaces.

**FOR PURPOSES OF SERVICING THIS APPLIANCE, ACCESSIBILITY CLEARANCES, WHERE GREATER, SHOULD TAKE PRECEDENCE OVER FIRE PROTECTION CLEARANCES.**

**▲ WARNING**

FURNACES MUST NOT BE INSTALLED DIRECTLY ON CARPET, TILE OR OTHER COMBUSTIBLE MATERIAL. INSTALLATION ON A COMBUSTIBLE MATERIAL OTHER THAN WOOD FLOORING MAY RESULT IN FIRE CAUSING DAMAGE, PERSONAL INJURY OR DEATH.

-GGD FURNACES CONFIGURED FOR DOWNFLOW INSTALLATIONS MAY NOT BE INSTALLED DIRECTLY TO A COMBUSTIBLE FLOOR. A SPECIAL FLOOR BASE IS REQUIRED.

-GFD upflow furnaces and -GGD furnaces mounted in the horizontal configuration are designed and certi-

fied for installation on combustible (wood only) floors. -GGD furnaces mounted in the downflow configuration may be installed on a cased evaporator coil mounted on a combustible (wood only) floor or (for installations without an evaporator coil) installed on a special combustible floor base mounted to a combustible (wood only) floor. The necessary floor base for installing a -GGD furnace in the downflow configuration to a combustible (wood only) floor is an accessory sold through finished goods. Following is a list of floor base models by furnace input size.

-GGD Furnace BTU's	Combustible Floor Base
60, 75	RXGC-B17
90, 105	RXGC-B21
120	RXGC-B24

Upflow furnaces are shipped with a bottom closure panel installed. When bottom return air is used, remove the panel by removing the two screws attaching the panel to the front base angle. See filter section for details.

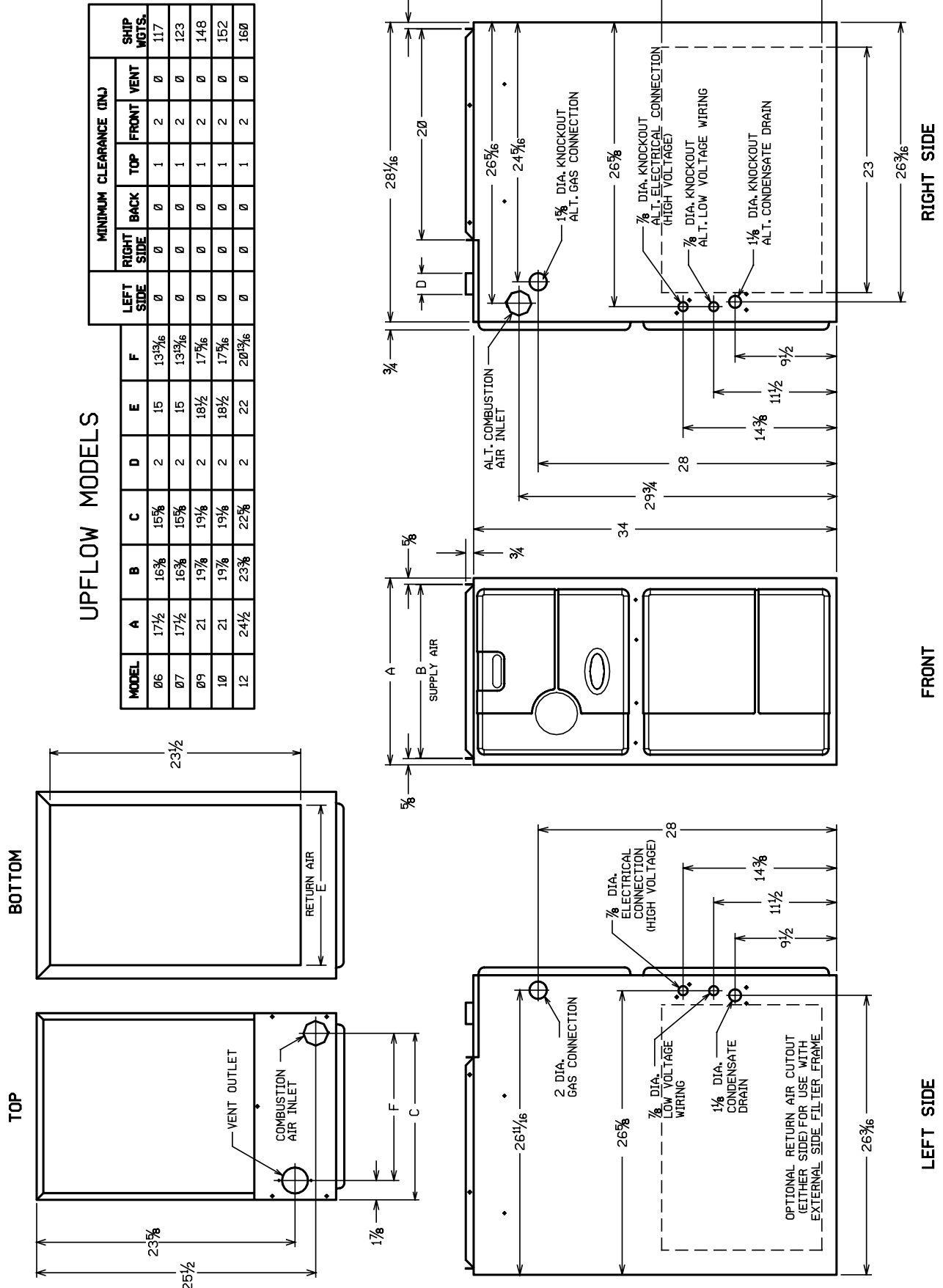
**SITE SELECTION**

1. Select a site in the building near the center of the proposed, or existing, duct system.
2. Give consideration to the vent system piping when selecting the furnace location. Vent from the furnace to the termination with minimal length and elbows.
3. Locate the furnace near the existing gas piping. If running a new gas line, locate the furnace to minimize the length and elbows in the gas piping.
4. Locate the furnace to maintain proper clearance to combustibles as shown in Figures 4 & 5.

**▲ WARNING**

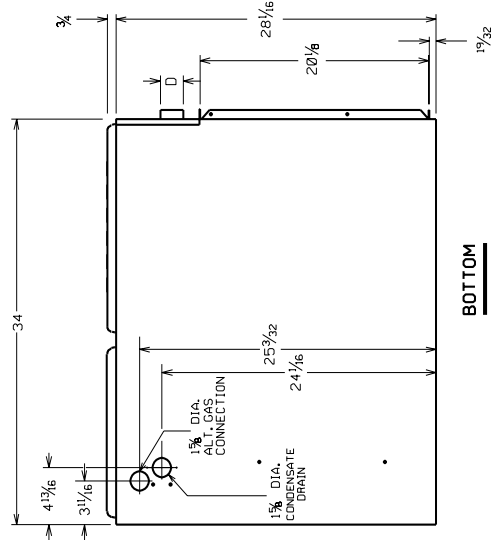
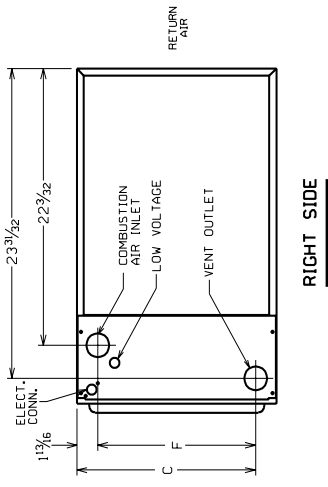
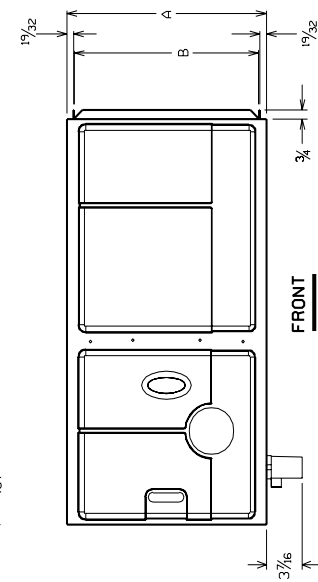
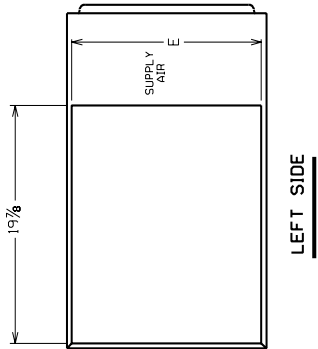
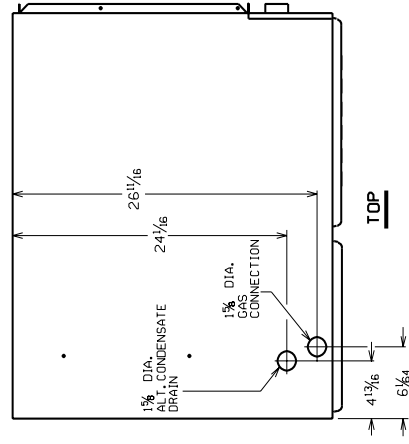
COMBUSTIBLE MATERIAL MUST NOT BE PLACED ON OR AGAINST THE FURNACE JACKET. THE AREA AROUND THE FURNACE MUST BE KEPT CLEAR AND FREE OF ALL COMBUSTIBLE MATERIALS INCLUDING GASOLINE AND OTHER FLAMMABLE VAPORS AND LIQUIDS. PLACEMENT OF COMBUSTIBLE MATERIALS ON, AGAINST OR AROUND THE FURNACE JACKET CAN CAUSE AN EXPLOSION OR FIRE RESULTING IN PROPERTY DAMAGE, PERSONAL INJURY OR DEATH. THE HOMEOWNER SHOULD BE CAUTIONED THAT THE FURNACE AREA MUST NOT BE USED AS A BROOM CLOSET OR FOR ANY OTHER STORAGE PURPOSES.

**FIGURE 6**  
**PHYSICAL DIMENSIONS AND CLEARANCE TO COMBUSTIBLES, UPFLOW MODELS**



**FIGURE 7**  
DIMENSIONS AND CLEARANCES TO COMBUSTIBLES, HORIZONTAL MODELS

MODEL	HORIZONTAL MODELS						MINIMUM CLEARANCE (IN)				SHIP WOLS.		
	A	B	C	D	E	F	LEFT SIDE	RIGHT SIDE	BACK	TOP		FRONT	VENT
06	17½	16¾	15¾	2	15¾	13¾	0	0	0	1	2	0	117
07	17½	16¾	15¾	2	16¾	13¾	0	0	0	1	2	0	123
09	21	19¾	19¾	2	20¾	17¾	0	0	0	1	2	0	148
10	21	19¾	19¾	2	20¾	17¾	0	0	0	1	2	0	152
12	24½	23¾	22¾	2	23¾	20¾	0	0	0	1	2	0	160

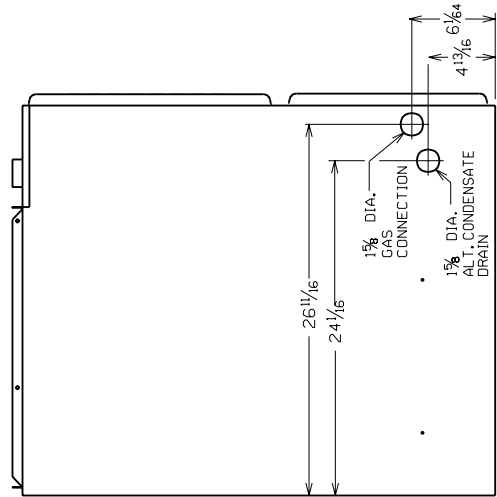
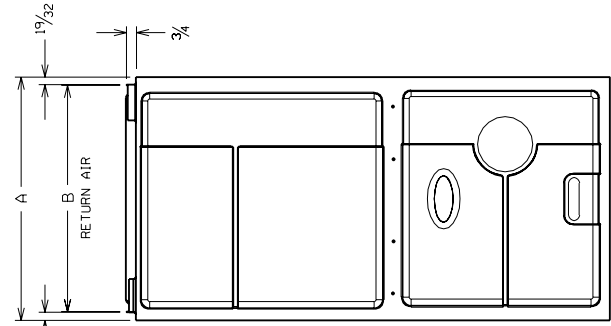
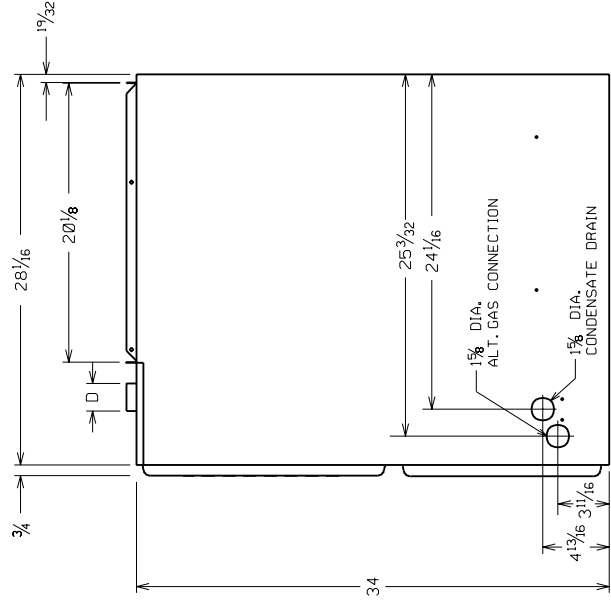
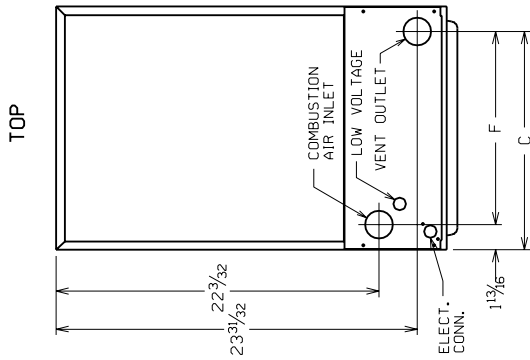
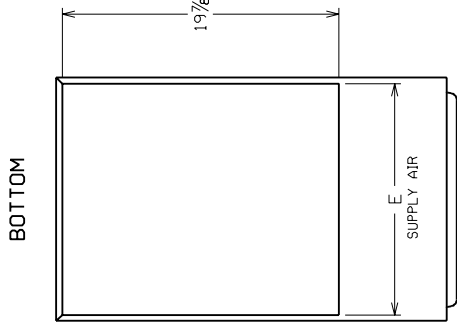


**IMPORTANT: THIS FURNACE MAY ONLY BE INSTALLED SO AS WHEN FACING THE FRONT OF THE FURNACE, SUPPLY AIR IS DISCHARGED ON THE LEFT HAND SIDE.**

**FIGURE 8**  
**DIMENSIONS AND CLEARANCES TO COMBUSTIBLES, DOWNFLOW MODELS**

**DOWNFLOW MODELS**  
 (Downflow Configuration)

MODEL	A	B	C	D	E	F	MINIMUM CLEARANCE (IN.)				SHIP WGT.S.	
							LEFT SIDE	RIGHT SIDE	BACK	TOP		FRONT
06	17½	16⅞	15½	2	16½	13⅞	0	0	1	2	0	117
07	17½	16⅞	15½	2	16½	13⅞	0	0	1	2	0	123
09	21	19⅞	19⅞	2	20½	17⅞	0	0	1	2	0	148
10	21	19⅞	19⅞	2	20½	17⅞	0	0	1	2	0	152
12	24½	23⅞	22½	2	23½	20⅞	0	0	1	2	0	160



A084901.S01  
 JWR 7-21-99

## DUCTING

Proper airflow is required for the correct operation of this furnace.

Too little airflow can cause erratic operation and can damage the heat exchanger. The duct system must carry the correct amount of air for heating and cooling if summer air conditioning is used.

Size the ducts according to acceptable industry standards and methods. The total static pressure drop of the air distribution system should not exceed 0.2" w.c.

### **▲ WARNING**

**NEVER ALLOW THE PRODUCTS OF COMBUSTION FROM THE FLUE TO ENTER THE RETURN AIR DUCTWORK OR THE CIRCULATED AIR SUPPLY. ALL RETURN DUCTWORK MUST BE ADEQUATELY SEALED AND SECURED TO THE FURNACE WITH SHEET METAL SCREWS; AND JOINTS, TAPED. SECURE ALL OTHER DUCT JOINTS WITH APPROVED CONNECTIONS AND SEAL AIRTIGHT. WHEN A FURNACE IS MOUNTED ON A PLATFORM WITH RETURN THROUGH THE BOTTOM, IT MUST BE SEALED AIRTIGHT BETWEEN THE FURNACE AND THE RETURN AIR PLENUM. THE FLOOR OR PLATFORM MUST PROVIDE PHYSICAL SUPPORT OF THE FURNACE WITHOUT SAGGING, CRACKS, OR GAPS AROUND THE BASE, PROVIDING A SEAL BETWEEN THE SUPPORT AND THE BASE.**

**FAILURE TO PREVENT PRODUCTS OF COMBUSTION FROM BEING CIRCULATED INTO THE LIVING SPACE CAN CREATE POTENTIALLY HAZARDOUS CONDITIONS, INCLUDING CARBON MONOXIDE POISONING THAT COULD RESULT IN PERSONAL INJURY OR DEATH.**

**DO NOT, UNDER ANY CIRCUMSTANCES, CONNECT RETURN OR SUPPLY DUCTWORK TO OR FROM ANY OTHER HEAT PRODUCING DEVICE SUCH AS A FIREPLACE INSERT, STOVE, ETC. DOING SO MAY RESULT IN FIRE, CARBON MONOXIDE POISONING, EXPLOSION, PERSONAL INJURY OR PROPERTY DAMAGE.**

**IMPORTANT:** Some high efficiency filters have a greater than normal resistance to airflow. This can adversely affect furnace operation. Be sure to check airflow if using any filter other than the factory-provided filter.

## UPFLOW UNITS

1. Position the unit to minimize long runs of duct or runs of duct with many turns and elbows.

### **▲ WARNING**

**UPFLOW FURNACE: A SOLID METAL BASE PLATE MUST BE INSTALLED IN THE FURNACE BOTTOM WHEN USING SIDE AIR RETURN. FAILURE TO INSTALL A BASE PLATE COULD CAUSE THE PRODUCTS OF COMBUSTION TO CIRCULATE INTO THE LIVING SPACE AND CREATE POTENTIALLY HAZARDOUS CONDITIONS, INCLUDING CARBON MONOXIDE POISONING OR DEATH.**

2. Open the return air compartment.
  - a. If using side return air, **do not remove the bottom base.**
  - b. Cut an opening in the side . The opening should be cut the full width of the knockouts on the unit.
 

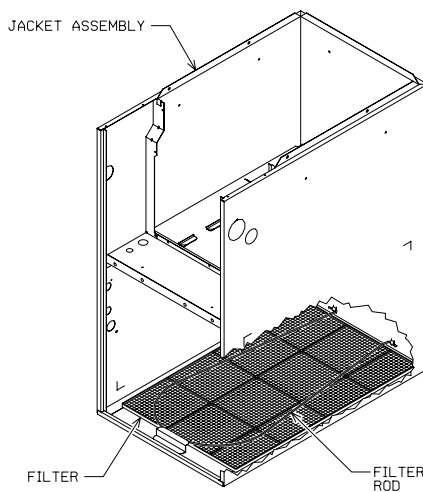
**NOTE:** When using side return, return air plenums, RXGR-C17B, C21B and C24B are available from the factory.
  - c. Remove the bottom base, if using bottom return air. Remove the panel by removing the two screws attaching the base to the front base angle. See Figure 6.
 

**NOTE:** Where the maximum airflow is 1800 CFM or more, both sides or the bottom must be used for return air.
3. Connect the return duct or return air cabinet to the unit. Make the connection air tight to prevent entraining combustion gases from an adjacent fuel-burning appliance.
4. **Be sure to have adequate space for the unit filter.**

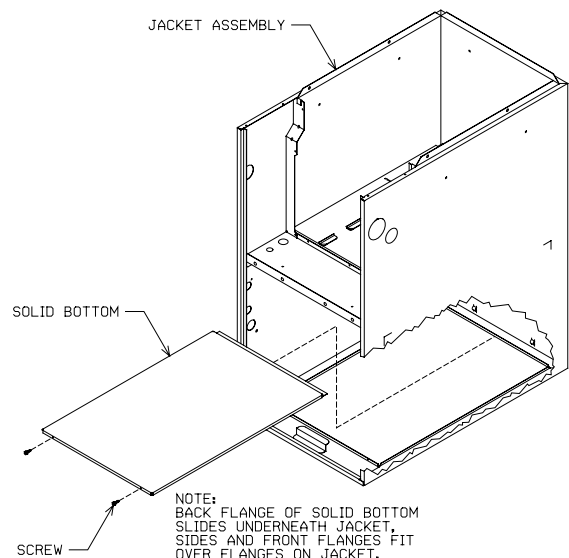
**NOTE:** DO NOT take return air from bathrooms, kitchens, furnace rooms, garages, utility or laundry rooms, or cold areas. DO NOT use a rear air return.
5. If summer air conditioning is desired, position the indoor coil on the top of the unit. Insure that no air can bypass this coil.
6. Connect the supply air plenum to the furnace plenum opening.

**IMPORTANT:** If a flexible duct connector must be used, it **MUST** be rated for a minimum temperature of 250°F. continuous.

**FIGURE 9  
BOTTOM PANEL REMOVAL**



**NOTE:** FILTER AND FILTER-ROD ARE SHIPPED ON TOP OF SOLID BOTTOM. REMOVE FILTER AND FILTER ROD TO ACCESS SOLID BOTTOM



**NOTE:** BACK FLANGE OF SOLID BOTTOM SLIDES UNDERNEATH JACKET. SIDES AND FRONT FLANGES FIT OVER FLANGES ON JACKET.

542201-B1

## DOWNFLOW UNITS

1. Position the unit to minimize long runs of duct or runs of duct with many turns and elbows.
2. If summer air conditioning is desired, position the indoor coil on the bottom of the unit. Insure that no air can bypass this coil.
3. If installing on a combustible floor and not using an air conditioning plenum, install the special non-combustible floor base. See Figure 7.

### ▲ WARNING

THE DOWNFLOW/HORIZONTAL FURNACE DESIGN IN DOWNFLOW MODE IS CERTIFIED FOR INSTALLATION ON A NON-COMBUSTIBLE FLOOR. USE THE SPECIAL BASE SPECIFIED ON THE FURNACE CLEARANCE LABEL. FAILURE TO INSTALL THE SPECIAL BASE MAY RESULT IN FIRE, PROPERTY DAMAGE, PERSONAL INJURY OR DEATH. THIS SPECIAL BASE IS SHIPPED FROM THE FACTORY AS AN ACCESSORY.

4. Connect the furnace to the supply air plenum.
5. Connect the return air ducting to the return air opening at the top of the unit. Make the connection air tight to prevent entraining combustion gases from an adjacent fuel-burning appliance.
6. Be sure to have adequate space for the unit filter.

**NOTE:** DO NOT take return air from bathrooms, kitchens, furnace rooms, garages, utility or laundry rooms, or cold areas.

## HORIZONTAL UNITS

**IMPORTANT:** This furnace may only be installed so as when facing the front of the furnace, supply air is discharged on the left hand side.

**IMPORTANT:** When installing the -GGD furnace in the horizontal configuration, a special kit must be used to convert the furnace for horizontal installation. The necessary kits are listed here.

FURNACE MODEL	HORIZONTAL CONVERSION KIT
(-)GGD-06	RXGY-G01
(-)GGD-07	RXGY-G02
(-)GGD-09	RXGY-G03
(-)GGD-10	RXGY-G04
(-)GGD-12	RXGY-G05

1. Position the unit to minimize long runs or runs with many turns and elbows.
2. If summer air conditioning is desired, position the indoor coil on the left end of the unit. Insure that no air can bypass this coil.
3. Connect the furnace to the supply air plenum.
4. Connect the return air ducting to the return air opening at the right end of the unit. Make the connection air tight to prevent entraining combustion gases from an adjacent fuel-burning appliance.
5. Be sure to have adequate space for the unit filter.

**NOTE:** DO NOT take return air from bathrooms, kitchens, furnace rooms, garages, utility or laundry rooms, or cold areas.

► Return air can come from : (1) outside the building, (2) from return air ducting from several inside rooms, or (3) a combination of the two. When using outside air, design and adjust the system to maintain a return air temperature above 50°F during the heating season. If return air comes from both inside and outside the building, design the ducting system with a diverting damper so that the volume of return air entering the furnace equals that which would normally enter through the return air

FIGURE 10  
COMBUSTIBLE FLOOR BASE

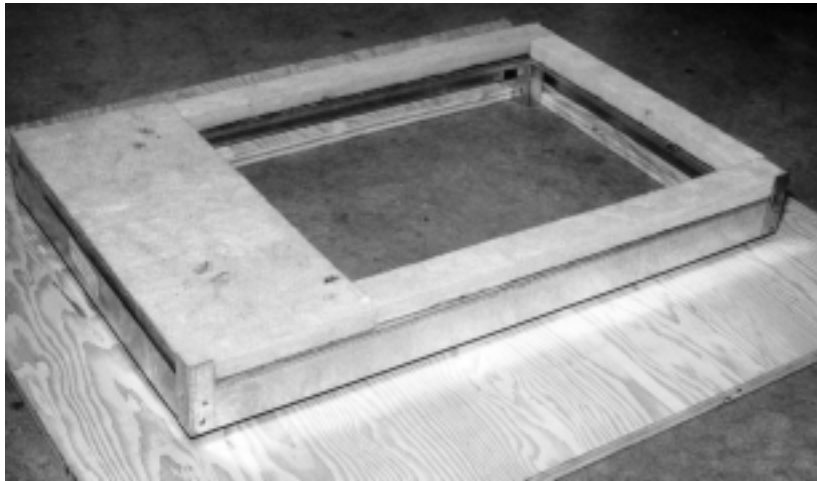
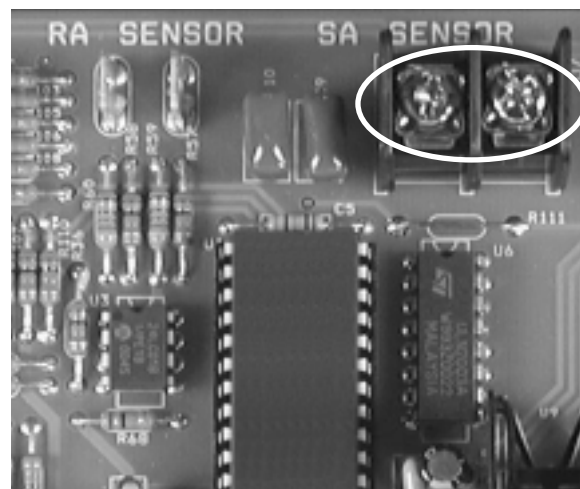


FIGURE 11  
SUPPLY AIR SENSOR TERMINALS





intake of the furnace. Any duct opening pulling return air from the outside must not be any higher nor closer than 10 feet to the furnace exhaust vent.

## SUPPLY AIR SENSOR

Each furnace comes shipped from the factory with a supply air sensor. Install the sensor, in the supply air plenum trunk, with two, field supplied, #8 sheet metal screws, using the following guidelines:

1. 12" downstream of the evaporator coil, if installed.
2. If no evaporator coil is used locate the sensor at least 18" downstream of the furnace outlet. Always locate the supply air sensor out of direct line of sight of the heat exchanger tubes, if possible.
3. Attach the supply air sensor wires onto the terminals marked "SA Sensor" on the integrated furnace control board (See Figure 5).

**NOTE:** Improper placement of the supply air sensor can adversely affect furnace temperature rise.

**NOTE:** In downflow circumstances where building construction does not allow for the placement of the sensor to fall within these parameters, the supply air sensor should not be connected. This means that the furnace will run under default parameters. When running under default parameters, the "82" code will appear for 1.5 minutes. After that the fault code will be stored in the control board's memory and will show upon power cycling. Default airflow parameters can be manually adjusted. See section discussing Integrated Furnace Control (IFC) board in this manual.

# VENTING AND COMBUSTION AIR PIPING

## GENERAL INFORMATION

### **▲ WARNING**

**READ AND FOLLOW ALL INSTRUCTIONS IN THIS SECTION. FAILURE TO PROPERLY VENT THIS FURNACE OR PROTECT IT FROM INADEQUATE COMBUSTION AIR CAN CAUSE CARBON MONOXIDE POISONING, AN EXPLOSION OR FIRE, RESULTING IN PROPERTY DAMAGE, PERSONAL INJURY OR DEATH.**

## OVER TEMPERATURE SAFETY SWITCHES

Furnaces are equipped with safety switches in the burner compartment to protect against over temperature conditions. If a switch is tripped it must be manually reset.

### **▲ WARNING**

**DO NOT JUMPER OVERTEMPERATURE SAFETY SWITCHES! IF ONE OF THESE OVER TEMPERATURE SWITCHES SHOULD TRIP, CALL A QUALIFIED INSTALLER, SERVICE AGENCY OR THE GAS SUPPLIER. DO NOT RESET THE SWITCHES WITHOUT TAKING CORRECTIVE ACTION. FAILURE TO DO SO CAN RESULT IN CARBON MONOXIDE POISONING OR DEATH. IF THIS UNIT IS INSTALLED IN A CLOSET, THE DOOR MUST BE CLOSED WHEN MAKING THIS CHECK.**

**REPLACE THE OVER TEMPERATURE SAFETY SWITCHES ONLY WITH THE IDENTICAL REPLACEMENT PART.**

## INSTALLATION WITH PRE-EXISTING VENT SYSTEMS

When the installation of this furnace replaces an existing furnace that is removed from a vent system serving other appliances (such as a water heater), the existing vent system is likely to be too large to properly vent the remaining attached appliances.

Follow the steps below with each appliance remaining connected to the original common vent system. Place the appliance to be tested in operation, while the other appliances remaining connected to the common vent system are not in operation. Test the operation of each appliance individually by the following method.

1. Permanently seal any unused openings in the common venting system.
2. Visually inspect the venting system for proper size and horizontal pitch and determine that there is no blockage, restriction, leakage, corrosion or other deficiencies which could cause an unsafe condition.
3. If practical, close all building doors, windows and all doors between the space where the appliances remaining connected to the common venting system are located. Turn on clothes dryers and any appliance not connected to the common venting system. Turn on any exhaust fans, such as range hoods and bathroom exhausts, so they will operate at maximum speed. Do not operate a summer exhaust fan. Close fireplace dampers.
4. Follow the lighting instructions. Place the appliance being inspected into operation. Adjust the thermostat so the appliance will operate continuously.
5. Test for spillage at the draft hood relief opening after 5 minutes of main burner operation. Use the flame of a match or candle, or smoke from a cigarette, cigar or pipe.
6. After it has been determined that each appliance that remains connected to the common venting system properly vents (when tested as outlined above), return doors, windows, exhaust fans, fireplace dampers and any other gas-burning appliance to their previous conditions of use.
7. If improper venting is observed during any of the above tests, resize the common venting system. Refer to latest edition of the National Fuel Gas Code ANSI Z223.1, or the CSA-GAMA venting tables for Category I furnaces.

**NOTE:** Schedule 40 ABS-DWV pipe and fittings may be used as an alternate to PVC pipe for the combustion air inlet and vent pipes.

**NOTE:** Cellular core PVC is also approved for use. It must be schedule 40 PVC-DWV cellular pipe manufactured under ASTM F-891.

## JOINING PIPE AND FITTINGS

### WARNING

**PVC SOLVENT CEMENTS AND PRIMERS ARE HIGHLY FLAMMABLE. PROVIDE ADEQUATE VENTILATION AND DO NOT ASSEMBLE COMPONENTS NEAR HEAT SOURCE OR AN OPEN FLAME. DO NOT SMOKE. AVOID SKIN OR EYE CONTACT. OBSERVE ALL CAUTIONS AND WARNINGS PRINTED ON MATERIAL CONTAINERS. FAILURE TO FOLLOW THESE GUIDELINES MAY RESULT IN FIRE, EXPLOSION OR ASPHYXIATION CAUSING PERSONAL INJURY OR DEATH.**

All pipe, fittings, solvent cement, primers and procedures must conform to American National Standard Institute and American Society for Testing and Materials (ANSI/ASTM) standards in the U.S.

Pipe and Fittings - ASTM-D1785, D2466, D2665, D2231, D2661, and F628

PVC Primer and Solvent Cement - ASTM-D2564

ABS Pipe and Fittings - Use ABS Primer and Solvent Cement D2235

Procedure for Cementing Joints - ASTM-D2855

In Canada all combustion air and vent pipe must be CSA- or ULC-certified Schedule 40 PVC, PVC-DWV or ABS-DWV.

**IMPORTANT:** The plastic combustion air and venting components are MADE of PVC. If using ABS piping, ensure that the solvent cement is compatible for joining PVC to ABS components or use a mechanical connection that can withstand the vent temperatures and is corrosion resistant.

## CEMENTING JOINTS

Properly seal all joints in the PVC vent using the following materials and procedures:

PVC CLEANER-PRIMER AND PVC MEDIUM-BODY SOLVENT CEMENT

**IMPORTANT:** After cutting pipe, remove all ragged edges and burrs. This is important to prevent increase in pressure drop throughout the system.

1. Cut pipe end square. Chamfer edge of pipe. Clean fitting socket and pipe joint area of all dirt, grease and moisture.
2. After checking pipe and socket for proper fit, wipe socket and pipe with cleaner-primer. Apply a liberal coat of primer to inside surface of socket and outside of pipe. READ INSTRUCTIONS INCLUDED WITH THE PRIMER FOR PROPER INSTALLATION.
3. Apply a thin coat of cement evenly in the socket. Quickly apply a heavy coat of cement to the pipe end and insert pipe into fitting with a slight twisting movement until it bottoms out.  
**NOTE:** Cement must be fluid; if not, recoat.
4. Hold the pipe in the fitting for 30 seconds to prevent the tapered socket from pushing the pipe out of the fitting.
5. Wipe all excess cement from the joint with a rag. Allow 15 minutes before handling. Cure time varies according to fit, temperature and humidity.

**NOTE:** Stir the solvent cement frequently while using. Use a natural bristle, one inch wide brush or the applicator supplied with the can.

**IMPORTANT:** For Proper Installation DO NOT use solvent cement that has become curdled, lumpy or thickened. DO NOT thin. Observe shelf precautions printed on containers. For application below 32°F, use only low-temperature-type solvent cement.

For correct installation of the vent pipe, follow the instructions provided by the manufacturers of the pipe, primer and solvent.

# NON-DIRECT VENT PIPE INSTALLATION (FOR VERTICAL TERMINATIONS ONLY)

## COMBUSTION AIR

### **▲ WARNING**

**ALWAYS PROVIDE THIS FURNACE AND ANY OTHER FUEL BURNING APPLIANCE WITH ENOUGH FRESH AIR FOR PROPER COMBUSTION AND VENTILATION OF THE FLUE GASES. MOST BUILDING CODES REQUIRE THAT OUTSIDE AIR BE SUPPLIED INTO THE FURNACE AREA. FAILURE TO DO SO CAN CAUSE DEATH FROM CARBON MONOXIDE POISONING.**

Provide adequate facilities for combustion and ventilation air in accordance with section 5.3, Air for Combustion and Ventilation of the National Fuel Gas Code, ANSI Z223.1 - latest edition; CAN/CGA B149.1 and .2, or applicable provisions of the local building codes. These combustion and ventilation facilities must not be obstructed.

**IMPORTANT:** Air for combustion and ventilation must not come from a corrosive atmosphere. Any furnace failure due to corrosive elements in the atmosphere is excluded from warranty coverage.

The following types of installation (but not limited to the following) REQUIRE OUTDOOR AIR for combustion, due to chemical exposures:

- Commercial buildings
- Buildings with indoor pools
- Furnaces installed in laundry rooms
- Furnaces in hobby or craft rooms
- Furnaces installed near chemical storage areas.

Exposure to the following substances in the combustion air supply (but not limited to the following) also REQUIRE OUTDOOR AIR for combustion:

- Permanent wave solutions
- Chlorinated waxes and cleaners
- Chlorine-based swimming pool chemicals
- Water softening chemicals
- De-icing salts or chemicals
- Carbon Tetrachloride
- Halogen type refrigerants
- Cleaning solvents (such as perchloroethylene)
- Printing inks, paint removers, varnishes, etc.
- Hydrochloric acid
- Cements and glues
- Anti-static fabric softeners for clothes dryers
- Masonry acid washing materials

Combustion air must be free of acid forming chemicals such as sulphur, fluorine, and chlorine. These elements are found in aerosol sprays, detergents, bleaches, cleaning solvents, air fresheners, paint and varnish removers, refrigerants and many other commercial and household products. Vapors from these products when burned in a gas flame form acid compounds. The acid compounds increase the dew point temperature of the flue products and produce highly corrosive condensate.

### **▲ WARNING**

**ALL FURNACE INSTALLATIONS MUST COMPLY WITH THE NATIONAL FUEL GAS CODE AND LOCAL CODES TO PROVIDE ADEQUATE COMBUSTION AND VENTILATION AIR FOR THE FURNACE. FAILURE TO DO SO CAN RESULT IN EXPLOSION, FIRE, PROPERTY DAMAGE, CARBON MONOXIDE POISONING, PERSONAL INJURY OR DEATH.**

Combustion air requirements are determined by whether the furnace is in an open (unconfined) area or in a confined space such as a closet or small room.

### **FURNACE LOCATED IN AN UNCONFINED SPACE**

**Using indoor air for combustion.**

An unconfined space must have at least 50 cubic feet for each 1,000 BTUH of the **total input for all appliances** in the space. Here are a few examples of the room sizes required for different inputs. The sizes are based on 8 foot ceilings. See Table 1.

**TABLE 1  
UNCONFINED SPACE DIMENSIONS**

BTUH Input	Minimum Sq. Feet With 8 foot Ceiling	Typical Room Size
60,000	375	15' x 25' OR 19' x 20'
75,000	469	15' x 32' OR 20' x 24'
90,000	563	20' x 28' OR 24' x 24'
105,000	657	20' x 33' OR 26' x 25'
120,000	750	25' x 30' OR 24' x 32'

If the open space containing the furnace is in a building constructed to severely limit outside air infiltration (contemporary energy efficient construction methods), outside air may still be required for the furnace to operate and vent properly. Outside air openings should be sized the same as for a confined space.

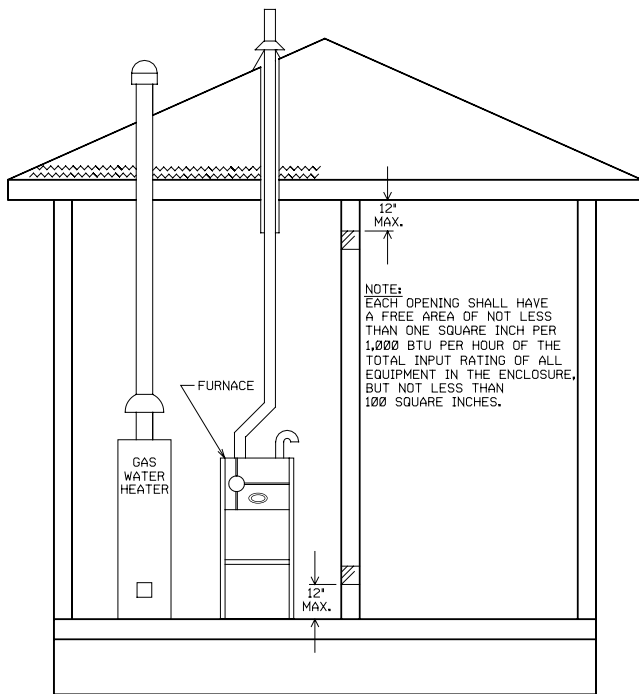
**FURNACE LOCATED IN A CONFINED SPACE.**

A confined space (any space smaller than shown before as “unconfined”) must have **openings into the space, which are located in accordance with the requirements set forth in the following subsections A and B.** The openings must be sized by how they connect to the heated area or to the outside, and by the input of all appliances in the space.

If the confined space is within a building with tight construction, combustion air must be taken from outdoors or areas freely communicating with the outdoors.

BTUH Input	Free Area Each Opening
60,000	100 square inches
75,000	100 square inches
90,000	100 square inches
105,000	105 square inches
120,000	120 square inches

**FIGURE 12  
AIR FROM HEATED SPACE**



**A. USING INDOOR AIR FOR COMBUSTION**

**IMPORTANT: DO NOT** take air from a heated space with a fireplace, exhaust fan or other device that may produce a negative pressure.

If combustion air is taken from the heated area (see Figure 12), the openings must each have at least **100 square inches of free area.** Each opening must have at least **one square inch of free area for each 1,000 BTUH of total input in the space.** See Table 2.

**B. USING OUTDOOR AIR FOR COMBUSTION**

**IMPORTANT:** Do not take air from an attic space that is equipped with power ventilation.

The confined space must communicate with the outdoors in accordance with Methods 1 or 2. The minimum dimension of air openings shall not be less than 3 inches. Where ducts are used, they shall be of the same cross-sectional area as the free area of the openings to which they connect.

**Method 1**

Two permanent openings, one located within 12 inches of the top and one located within 12 inches of the bottom of the enclosure, shall be provided. The openings shall communicate directly, or by ducts, with the outdoors or spaces (crawl or attic) that freely communicate with the outdoors.

- a. Where directly communicating with the outdoors or where communicating to the outdoors through vertical ducts as shown in Figure 13, each opening shall have a minimum free area of 1 square inch for each 4000 BTUH of total appliance input rating in the enclosure. See Table 3.

**TABLE 3  
VERTICAL OUTDOOR AIR OPENING DIMENSIONS**

BTUH Input	Free Area Each Opening	Round Pipe Size
60,000	15.00 square inches	5"
75,000	18.75 square inches	5"
90,000	22.50 square inches	6"
105,000	26.25 square inches	6"
120,000	30.00 square inches	7"

- b. Where communicating with outdoors through horizontal ducts, each opening shall have a minimum free area of 1 square inch for each 2000 BTUH of total input rating of all equipment in the enclosure. See Table 4 and Figure 14.

TABLE 4 HORIZONTAL OUTDOOR AIR OPENING DIMENSIONS		
BTUH Input	Free Area Each Opening	Round Pipe Size
60,000	30.00 square inches	7"
75,000	37.50 square inches	7"
90,000	45.00 square inches	8"
105,000	52.50 square inches	9"
120,000	60.00 square inches	9"

**Method 2**

One permanent opening, located within 12 inches of the top of the enclosure, shall be permitted where the equipment has clearances of at least 1 inch from the sides and back and 6 inches from the front of the appliance. The opening shall directly communicate with the outdoors or communicate through a vertical or horizontal duct to the outdoors or spaces (crawl or attic) that freely communicate with the outdoors, and shall have a minimum free area of:

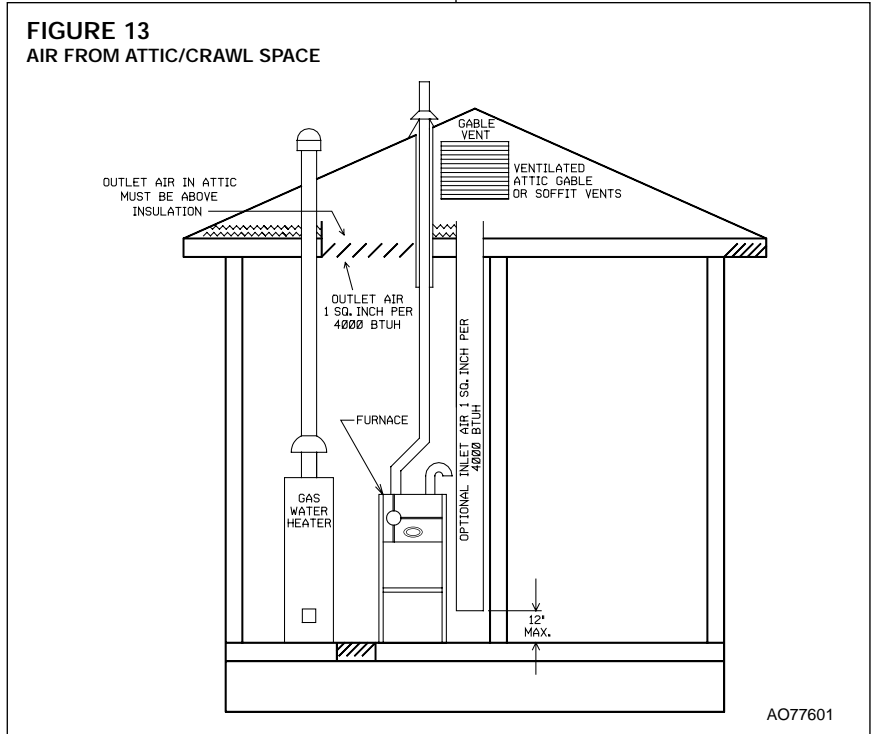
- a. One square inch for each 3000 BTUH of the total input rating of all equipment located in the enclosure (see Table 5), and
- b. Not less than the sum of the areas of all vent connectors in the confined space.

If the unit is installed where there is an exhaust fan, sufficient ventilation must be provided to prevent the exhaust fan from creating a negative pressure.

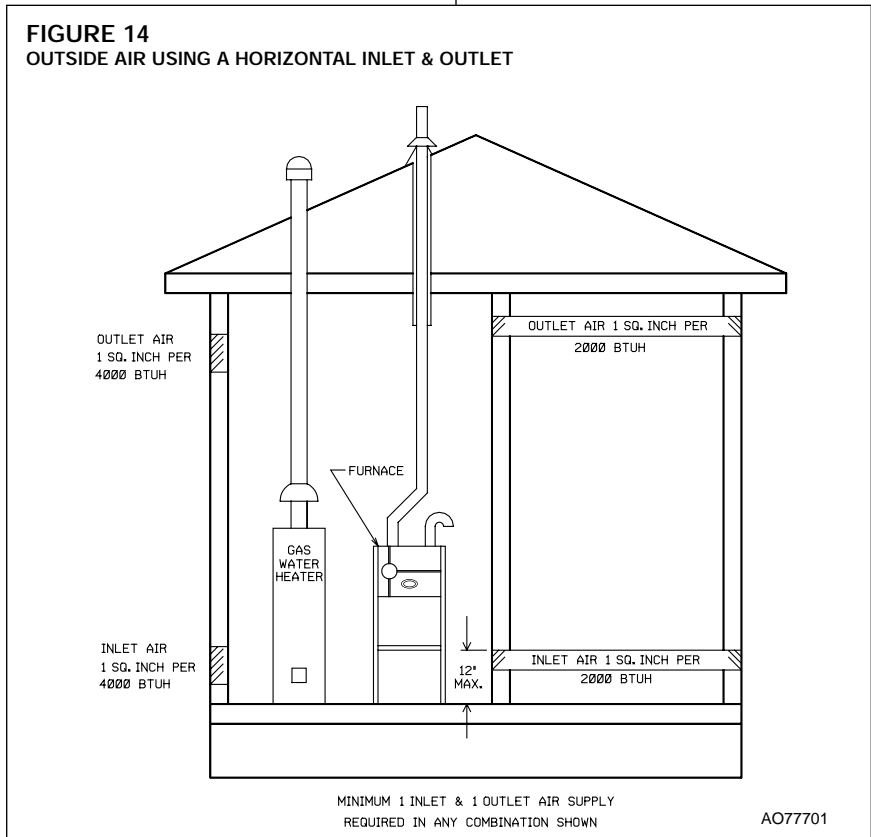
TABLE 5 VERTICAL OR HORIZONTAL OUTDOOR AIR OPENING DIMENSIONS		
BTUH Input	Free Area Each Opening	Round Pipe Size
60,000	20.00 square inches	6"
75,000	25.00 square inches	6"
90,000	30.00 square inches	7"
105,000	35.00 square inches	7"
120,000	40.00 square inches	8"

Combustion air openings must not be restricted in any manner.  
**CONSULT LOCAL CODES FOR SPECIAL REQUIREMENTS.**

**FIGURE 13  
AIR FROM ATTIC/CRAWL SPACE**



**FIGURE 14  
OUTSIDE AIR USING A HORIZONTAL INLET & OUTLET**



## INSTALLATION GUIDELINES

**IMPORTANT:** When installed as a non-direct furnace, only vertical terminations are allowed. Do not use horizontal terminations when the furnace is installed with a non-direct vent.

All exhaust vent piping must be installed in compliance with Part 7, Venting of Equipment, of the latest edition of the National Fuel Gas Code NFPA 54/ANSI A223.1, or CAN/CGA-B149.1 and .2, local codes or ordinances and these instructions.

### VENTING GUIDELINES - Non-Direct Vent

1. **IMPORTANT:** Do not common vent with any other appliance. Do not install in the same chase or chimney with a metal or high temperature plastic pipe from another gas or fuel-burning appliance unless the required minimum clearances to combustibles are maintained between the PVC pipe and other pipes.
2. Use only medium or long radius sweep elbows.
 

**NOTE:** For upflow and downflow installations, extend the exhaust pipe a minimum of 18" vertically above the furnace cabinet before turning the vent.
3. Vertical vent piping is preferred.
4. Install all horizontal piping as follows:
  - Slope horizontal vent piping upward a minimum of 1/4" per foot of run so that condensate drains toward the furnace.
  - Support horizontal vent piping at least every four feet. No sags or dips are permitted.
5. Insulate all vent runs through unconditioned spaces where below-freezing temperatures are expected, with 1" thick medium density, foil faced fiber glass or equivalent

Rubatex/Armaflex insulation. For horizontal runs where water may collect and freeze, wrap the vent pipe with self-regulating, 3 or 5 Watt heat tape. The heat tape must be U.L. listed and installed per the manufacturer's instructions.

6. All piping between the furnace and the roof penetration is 2" or 3" as specified in Table 6. Table 6 lists the maximum allowable exhaust vent pipe length for the number of elbows used, based on the furnace size.

**IMPORTANT:** Use Only standard vertical terminations when installing the modulating furnace as a non-direct vent appliance.

7. The minimum vent length is 5 feet.
8. All piping through the roof is 2". **When using 3" pipe, reduce to 2" within 18" of the inside of the roof.**
9. Vertical through-the-roof installations do not require any special vent termination. **Use 2" PVC pipe extending a minimum of 12 inches above the anticipated level of snow accumulation.**

**► TABLE 6  
NON-DIRECT VENT APPLICATIONS  
MAXIMUM ALLOWABLE LENGTH IN FEET OF EXHAUST PIPE**

UPFLOW FURNACES					
FURNACE INPUT	PIPE SIZE	TERMINATION (VERTICAL VENT TERMINATIONS ONLY)	NUMBER OF ELBOWS 45° OR 90° MEDIUM / LONG RADIUS ONLY		
			1 - 2	3 - 4	5 - 6
60,000	2"	STANDARD	40'	35'	30'
	3"	STANDARD	120'	120'	120'
75,000	2"	STANDARD	20'	15'	10'
	3"	STANDARD	120'	120'	120'
90,000	3"	STANDARD	110'	105'	95'
105,000	3"	STANDARD	110'	105'	95'
120,000	3"	STANDARD	45'	35'	30'
DOWNFLOW/HORIZONTAL FURNACES					
60,000	2"	STANDARD	30'	25'	20'
	3"	STANDARD	120'	120'	120'
75,000	2"	STANDARD	20'	15'	10'
	3"	STANDARD	120'	120'	120'
90,000	3"	STANDARD	90'	80'	75'
105,000	3"	STANDARD	45'	40'	35'
120,000	3"	STANDARD	40'	35'	30'

# DIRECT VENT PIPE INSTALLATION

## ▲ WARNING

READ AND FOLLOW ALL INSTRUCTIONS IN THIS SECTION. FAILURE TO PROPERLY VENT THIS FURNACE CAN CAUSE CARBON MONOXIDE POISONING OR AN EXPLOSION OR FIRE, RESULTING IN PROPERTY DAMAGE, PERSONAL INJURY OR DEATH.

Direct vent installations require a dedicated combustion air and venting system. All air for combustion is taken from outside and all combustion products are discharged to the outdoors. Therefore, no ventilation or combustion air openings are required.

## INSTALLATION GUIDELINES

All exhaust piping must be installed in compliance with Part 7, "Venting of Equipment," of the latest edition of the National Fuel Gas Code NFPA 54, 90A and 90B ANSI Z223.1-, local codes or ordinances and these instructions.

- IMPORTANT:** Do not common vent with any other appliance. Do not install in the same chase or chimney with a metal or high temperature plastic pipe from another gas or fuel-burning appliance unless the required minimum clearances to combustibles are maintained between the PVC pipe and other pipes.

- Use only medium or long radius sweep elbows.

**NOTE:** For upflow and downflow installations, extend the combustion air exhaust pipe a minimum of 18" vertically above the furnace cabinet before turning the vent.

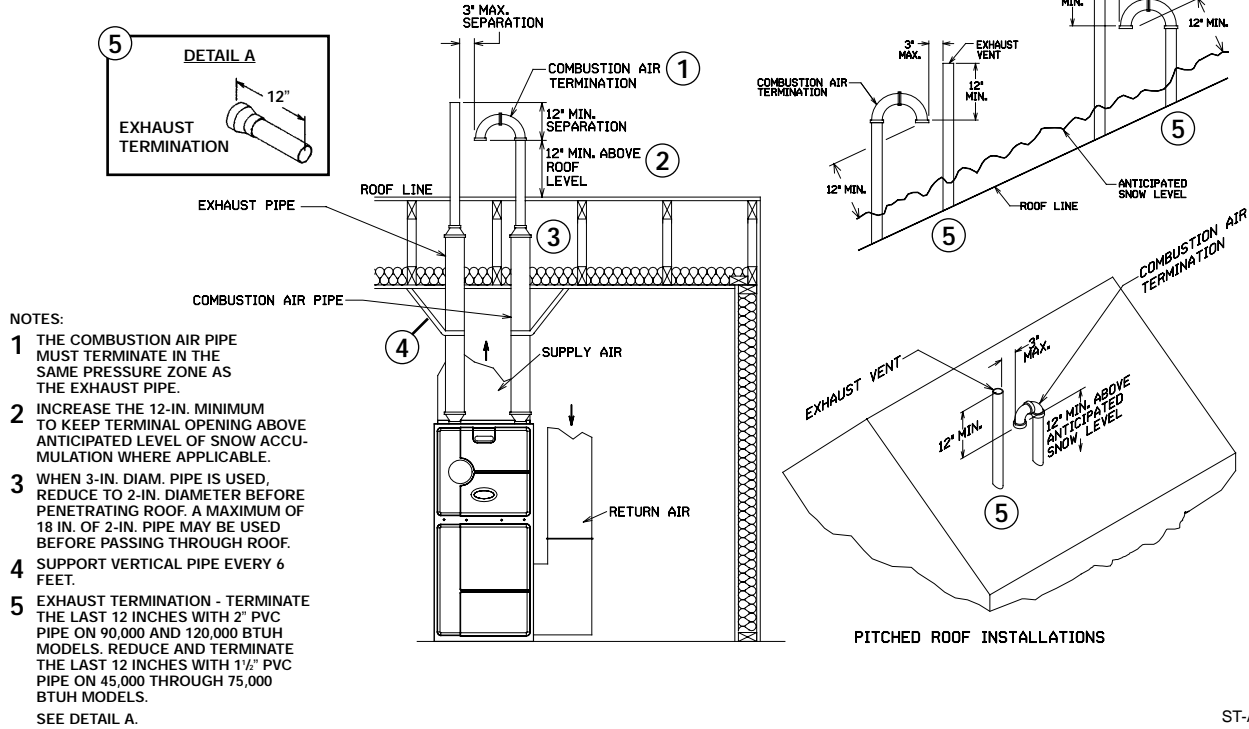
- Vertical piping is preferred.
- Install all horizontal piping as follows:
  - Slope horizontal vent piping upward a minimum of 1/4" per foot of run so that condensate drains toward the furnace.
  - Support horizontal vent piping at least every four feet. No sags or dips are permitted.

► **TABLE 7**  
**DIRECT VENT APPLICATIONS**  
 MAXIMUM ALLOWABLE LENGTH IN FEET OF EACH EXHAUST PIPE AND INTAKE PIPE

UPFLOW FURNACES						
FURNACE INPUT	PIPE SIZE	TERMINATION	VENT TERMINATION KIT RECOMMENDED	NUMBER OF ELBOWS 22½°, 45° OR 90° MEDIUM / LONG RADIUS ONLY		
				1 - 2	3 - 4	5 - 6
60,000	2"	STANDARD	RXGY-D02	40'	35'	30'
		CONCENTRIC	RXGY-E03			
		ALTERNATE	RXGY-D02	30'	25'	20'
	3"	STANDARD	RXGY-D03	120'	120'	120'
		CONCENTRIC	RXGY-E03			
		ALTERNATE	RXGY-D03	110'	105'	100'
75,000	2"	STANDARD	RXGY-D02	20'	15'	10'
	3"	STANDARD	RXGY-D03	120'	120'	120'
		CONCENTRIC	RXGY-E03			
		ALTERNATE	RXGY-D03	100'	95'	85'
90,000	3"	STANDARD	RXGY-D03	110'	105'	95'
		CONCENTRIC	RXGY-E03			
		ALTERNATE	RXGY-D03	50'	40'	35'
105,000	3"	STANDARD	RXGY-D03	110'	105'	95'
		CONCENTRIC	RXGY-E03			
		ALTERNATE	RXGY-D03	50'	40'	35'
120,000	3"	STANDARD	RXGY-D03	45'	35'	30'
		CONCENTRIC	RXGY-E03			
		ALTERNATE	RXGY-D03	45'	35'	30'
		ALTERNATE	RXGY-D04	105'	95'	90'
DOWNFLOW/HORIZONTAL FURNACES						
60,000	2"	STANDARD	RXGY-D02	30'	25'	20'
		CONCENTRIC	RXGY-E03	30'	25'	20'
	3"	STANDARD	RXGY-D03	120'	120'	120'
		CONCENTRIC	RXGY-E03			
75,000	2"	STANDARD	RXGY-D02	20'	15'	10'
		CONCENTRIC	RXGY-E03	20'	15'	10'
	3"	STANDARD	RXGY-D03	120'	120'	120'
		CONCENTRIC	RXGY-E03			
90,000	3"	STANDARD	RXGY-D03	70'	60'	55'
		CONCENTRIC	RXGY-E03	70'	60'	55'
105,000	3"	STANDARD	RXGY-D03	45'	40'	35'
		CONCENTRIC	RXGY-E03	45'	40'	35'
120,000	3"	STANDARD	RXGY-D03	40'	35'	30'
		CONCENTRIC	RXGY-E03	40'	35'	30'



**FIGURE 15**  
**STANDARD VERTICAL DIRECT VENTING**  
**UPFLOW MODEL SHOWN (TYPICAL FOR DOWNFLOW/HORIZONTAL MODELS)**



ST-A0407-00

5. Insulate all vent runs through unconditioned spaces where below-freezing temperatures are expected with 1" thick medium density, foil faced fiber glass or equivalent Rubatex/Armaflex insulation. For horizontal runs where water may collect, wrap the vent pipe with self-regulating, 3 or 5 Watt heat tape. The heat tape must be U.L. listed and installed per the manufacturer's instructions.
6. All piping between the furnace and the roof or outside wall penetration is 2" or 3" as specified in Table 7. Table 7 lists the maximum allowable length for the exhaust vent pipe and intake air pipe for the number of elbows used, based on the type of termination and furnace size.
7. The minimum vent length is 5 feet.
8. All piping through the roof or outside wall is 2". **When using 3" pipe, reduce to 2" within 18" of the inside of the roof or outside wall (except 120,000 BTUH model using the RXGY-D04 Horizontal Vent Kit).**
9. Terminate the vent using one of the following termination options.

**VERTICAL TERMINATIONS**  
**STANDARD VERTICAL TERMINATIONS (See Figure 15)**

**Combustion Air Piping:** Use two medium-radius sweep elbows to keep the inlet downward and prevent the entry of rain. The inlet opening of the combustion air termination must be a minimum of 12" above the anticipated level of snow accumulation.

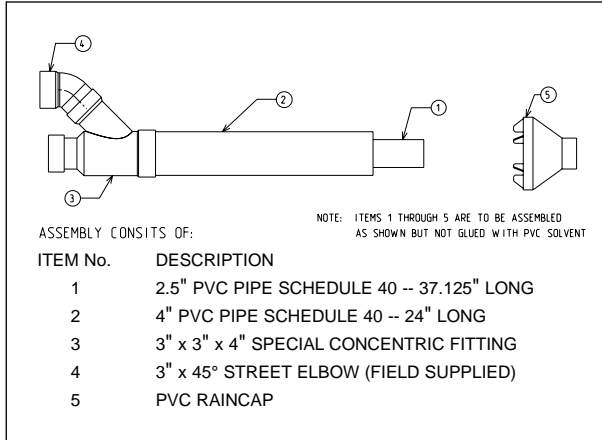
**Exhaust Vent Piping:** The exhaust vent must terminate at least 12 inches above the combustion air termination inlet. The 2" vent pipe used to penetrate the roof must be reduced to 1 1/2" PVC for the last 12" for the 60,000 and 75,000 BTUH furnace models. No reduction of the 2" pipe is necessary for the 90,000 through 120,000 BTUH models. The maximum length of the exposed vent pipe above the roof is 30".

**CONCENTRIC TERMINATIONS**

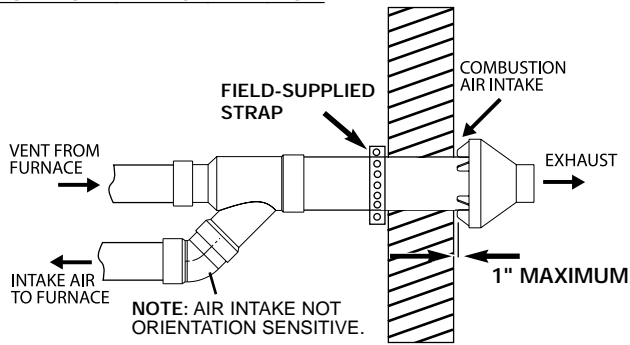
**CONCENTRIC VENT KIT  
NO. RXGY-E03 (SEE FIGURE 16)**

This kit is for vertical and horizontal intake air/vent runs. One 5-in. diameter hole is required for installation. See Figure 13 for the general layout. Complete installation instructions are included with the kit.

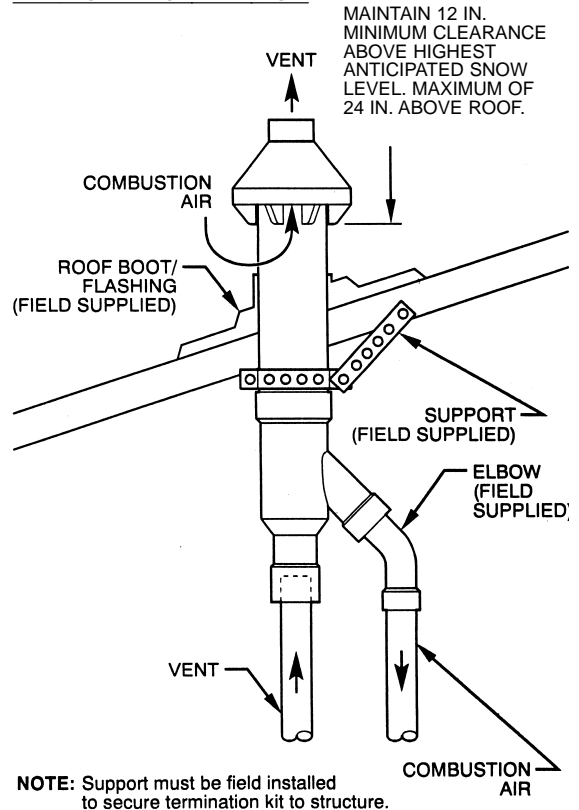
**FIGURE 16  
CONCENTRIC VENT KIT NO. RXGY-E03  
(DIRECT VENT INSTALLATIONS)**



**HORIZONTAL INSTALLATION**



**VERTICAL INSTALLATION**



## HORIZONTAL TERMINATIONS

### STANDARD HORIZONTAL TERMINATIONS (SEE FIGURE 17)

**NOTE:** All furnaces with horizontal air intakes (except those using horizontal concentric vent kit RXGY-E03) must have a drain tee assembly and trap installed in the combustion air pipe as close to the furnace as possible. This is to drain any water that may enter the combustion air pipe to prevent it from entering the furnace vestibule area. These parts are included in horizontal vent kits RXGY-D02, RXGY-D03 and RXGY-D04.

**NOTE:** The combustion air and exhaust terminations must be at least 12 inches above grade or anticipated snow levels. Use alternate horizontal terminations when termination locations are limited and higher snow levels are anticipated.

**NOTE:** Ensure the location of the combustion air inlet with respect to the exhaust vent terminal complies with Figure 17, detail C.

**Combustion Air Piping:** Use a 2" PVC coupling with a wind deflector vane (provided) installed as follows:

1. Install a 2" coupling to the combustion air pipe at the outside wall to prevent the termination from being pushed inward.
2. Cut a 2 1/4" length of 2" PVC pipe and connect this to the coupling.
3. Connect another 2" coupling to the end of the 2 1/4" length of pipe. Terminate this outer coupling 4 inches from the wall.
4. Attach the vane in the final 2" coupling in the vertical position with PVC cement.

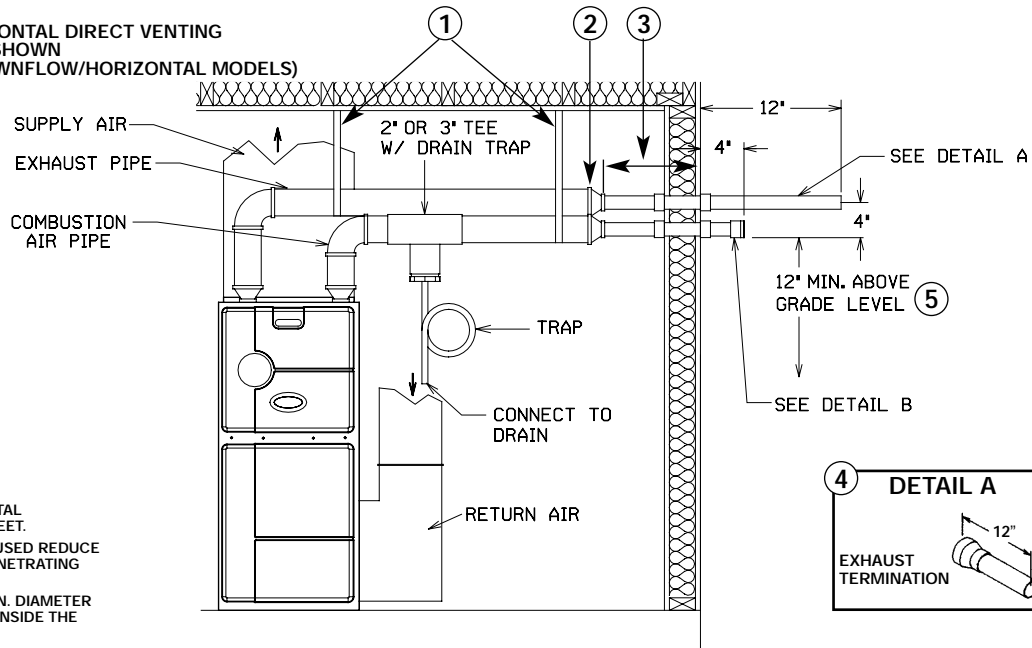
**IMPORTANT:** To insure proper furnace operation, install the vane in the vertical position as shown in Figure 17, Detail B. Failure to install the vane properly can result in nuisance tripping of the pressure switch.

### Exhaust Vent Piping:

**60,000 and 75,000 BTUH models:** Install a 2" to 1 1/2" reducer coupling at the outside wall to prevent the termination from being pushed inward. Reduce the 2" vent pipe used to penetrate the wall to 1 1/2" PVC for the last 12" of the run. Terminate the 1 1/2" PVC exhaust vent at least 12 inches from the outside wall.

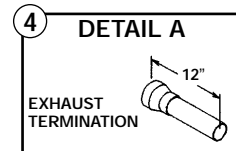
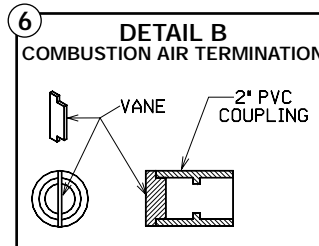
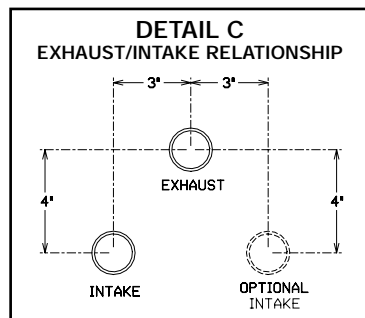
**90,000 through 120,000 BTUH models:** Install a 2" coupling at the outside wall to prevent the termination from being pushed inward. No reduction of the 2" pipe used to penetrate the wall is necessary. Terminate the 2" PVC exhaust vent at least 12 inches from the outside wall.

**FIGURE 17**  
STANDARD HORIZONTAL DIRECT VENTING  
UPFLOW MODEL SHOWN  
(TYPICAL FOR DOWNFLOW/HORIZONTAL MODELS)



#### NOTES:

- 1 SUPPORT HORIZONTAL PIPE EVERY FOUR FEET.
- 2 WHEN 3 IN. PIPE IS USED REDUCE TO 2 IN. BEFORE PENETRATING OUTSIDE WALL.
- 3 18 IN. MAXIMUM. 2 IN. DIAMETER PIPE MAY BE USED INSIDE THE WALL.
- 4 DETAIL "A" - EXHAUST TERMINATION TERMINATE THE LAST 12 INCHES WITH 2" PVC PIPE ON 90,000 AND 120,000 BTUH MODELS. REDUCE AND TERMINATE THE LAST 12 INCHES WITH 1 1/2" PVC PIPE ON 45,000 THROUGH 75,000 BTUH MODELS.
- 5 INCREASE THE 12 IN. MINIMUM ABOVE GRADE TO KEEP TERMINAL OPENINGS ABOVE ANTICIPATED LEVEL OF SNOW ACCUMULATION WHERE APPLICABLE.
- 6 DETAIL "B", INSTALL WIND DEFLECTOR VANE IN 2 IN. PVC COUPLING IN VERTICAL POSITION USING PVC SOLVENT. THE COMBUSTION AIR TERMINATION MUST BE IN THE SAME PRESSURE ZONE AS THE EXHAUST TERMINATION.



ST-A0407-00

**ALTERNATE HORIZONTAL TERMINATIONS** (See Figure 18)

**NOTE:** This method is NOT ALLOWED on downflow furnaces.

**NOTE:** The combustion air and exhaust terminations must be at least 12 inches above grade or anticipated snow levels. Alternate horizontal terminations allow the combustion air and exhaust terminations to be raised a maximum of 60 inches above the wall penetrations to maintain the required clearance.

**NOTE:** If combustion air vent pipe is extended more than 24 inches, insulate the vent pipe between the two outside 90° elbows with closed cell insulation such as rubatex, armaflex or equivalent.

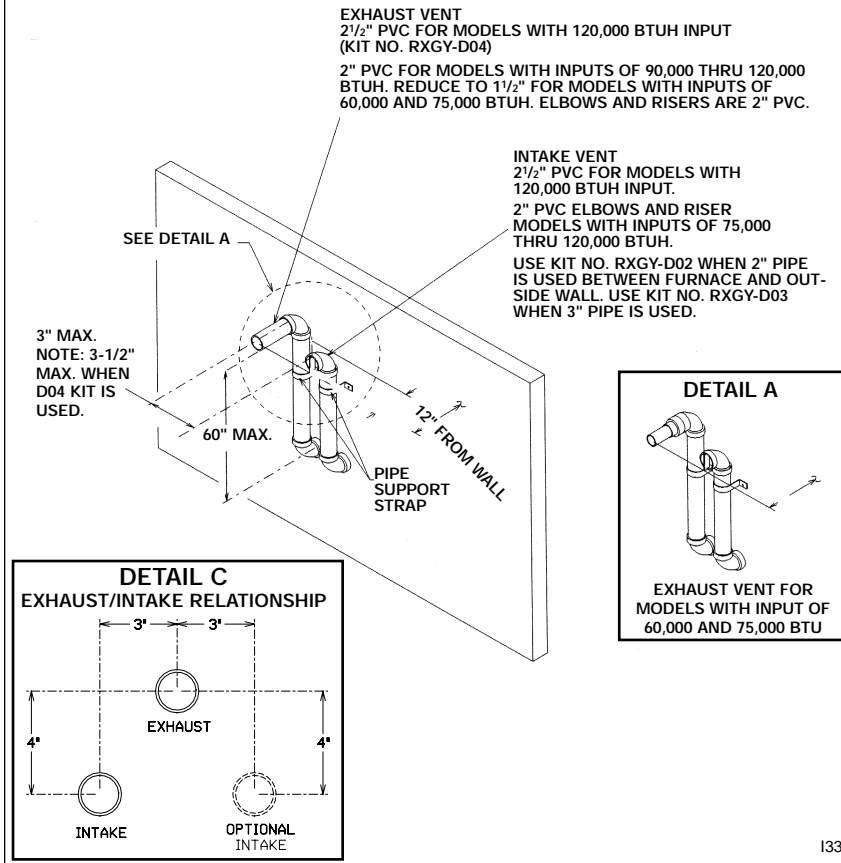
**NOTE:** Ensure the location of the combustion air inlet with respect to the exhaust vent terminal complies with Figure 18.

**Combustion Air Piping:** Use a 2" PVC elbow with a wind deflector vane (provided) installed as follows:

1. Install a 2" elbow to the combustion air pipe at the outside wall to prevent the termination from being pushed inward.
2. Cut an adequate length of 2" PVC pipe as needed to clear the anticipated snow level and connect this to the elbow.
3. Connect another 2" elbow to the end of the pipe such that the inlet is facing away from the wall. This outer coupling must terminate 4 inches from the wall.
4. Attach the vane in the final 2" elbow in the vertical position with PVC solvent.

**IMPORTANT:** To insure proper furnace operation, the supplied vane must be installed in the vertical position as shown in Figure 18, Detail A.

**FIGURE 18**  
ALTERNATE HORIZONTAL DIRECT VENT TERMINATION



1339

**Exhaust Vent Piping:**

1. Install a 2" elbow to the exhaust vent pipe at the outside wall to prevent the termination from being pushed inward.
2. Cut an adequate length of 2" PVC pipe as needed to insure proper location of the exhaust vent termination with respect to the combustion air inlet and connect this to the elbow.
3. Connect another 2" elbow to the end of the pipe such that the inlet is facing away from the wall.

**Exhaust Vent Termination:**

**60,000 and 75,000 BTUH models:** Reduce the 2" vent pipe used to penetrate the wall and extend the terminations to 1 1/2" PVC for the last 12" of the run. Install a 2" to 1 1/2" reducer bushing in the last 2" elbow. Connect a length of 1 1/2" PVC pipe such that the exhaust vent terminates at least 12 inches from the outside wall. See Figure 18, Detail A.

**90,000 through 120,000 BTUH models:** No reduction of the 2" pipe used to penetrate the wall is necessary. Terminate the 2" PVC exhaust vent at least 12 inches from the outside wall.

**120,000 BTUH model with the RXGY-D04 Horizontal Vent Kit:** Venting and terminations install the same as above except the 2" pipe and connectors are replaced with 2 1/2" pipe and connectors.

## LOCATION REQUIREMENTS HORIZONTAL DIRECT VENTS

### ▲ CAUTION

THE COMBUSTION PRODUCTS AND MOISTURE IN THE FLUE GASES WILL CONDENSE AS THEY LEAVE THE TERMINATION. THE CONDENSATE CAN FREEZE ON THE EXTERIOR WALL, UNDER THE EAVES AND ON SURROUNDING OBJECTS. SOME DISCOLORATION TO THE EXTERIOR OF THE BUILDING IS TO BE EXPECTED. HOWEVER, IMPROPER LOCATION OR INSTALLATION CAN RESULT IN STRUCTURAL OR EXTERIOR FINISH DAMAGE TO THE BUILDING AND MAY RECIRCULATE PRODUCTS OF COMBUSTION INTO THE COMBUSTION AIR TERMINAL AND FREEZE.

**NOTE:** In Canada vent terminations must be in accordance with the current CSA-B149 Gas Installation Code and/or local codes.

The vent must be installed with the following minimum clearances. See Figures 19 and 20.

1. Locate the bottom of the vent terminal and the air inlet at least 12 inches above grade. Increase the 12-in. minimum to keep the terminal openings above the level of snow accumulation, where applicable.
2. Do not terminate the vent over public walkways or over an area where condensate or vapor could create a nuisance or hazard.
3. Locate the vent terminal at least one foot from any opening through which flue gases could enter a building.
4. Locate the vent terminal at least 3 feet above any forced air inlet located within 10 feet, except the combustion air inlet of a direct vent appliance.
5. Allow the vent terminal minimum horizontal clearance of 4 feet from electric meters, gas meters, regulators and relief equipment.
6. Locate the furnace combustion air inlet a sufficient distance from the vent of any other gas or fuel burning appliance or electric clothes dryer to prevent recirculation of the flue gases into the furnace combustion air inlet. The only exception to this requirement is the case of multiventing two or more furnaces, which is covered in the section on multiventing in these instructions.

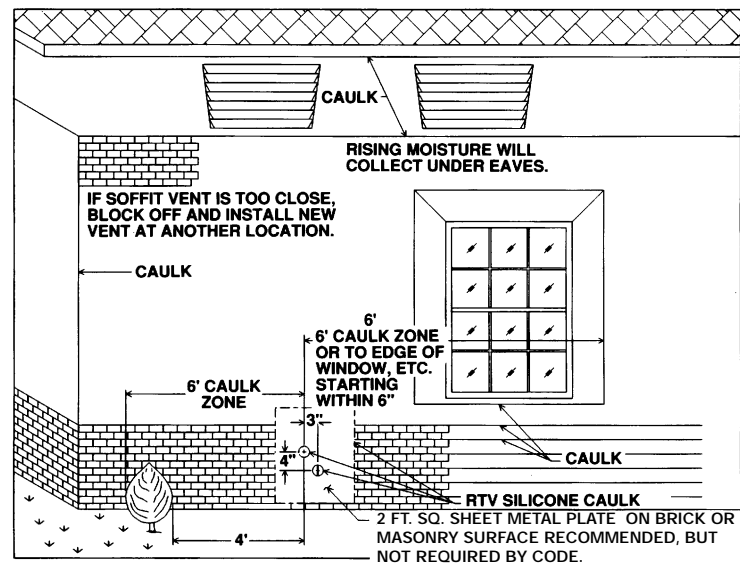
In addition to the minimum clearances listed above, the vent location should be governed by the following guidelines.

1. Do not terminate under any kind of patio or deck. If running the vent under a deck, insulate it to insure no condensate freezes and blocks the pipe.
2. Do not terminate behind any area that may allow the flue products to become stagnant and recirculate.
3. Do not locate on the side of a building with prevailing winter winds. This will help prevent moisture from freezing on walls and overhangs (under eaves).
4. Do not extend vent directly through brick or masonry sur-

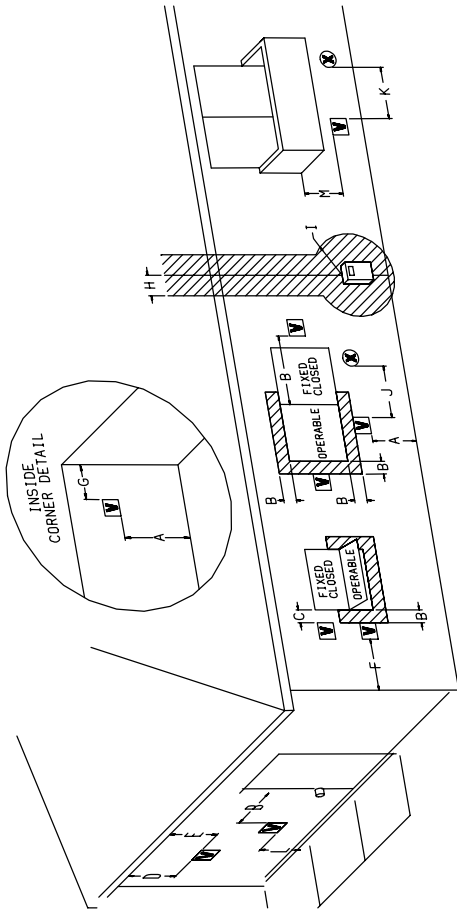
faces. Use a rust-resistant sheet metal or plastic backing plate behind vent. See Figure 16.

5. Do not locate too close to shrubs as condensate may stunt or kill them.
6. Minimum vertical clearances of 1 foot are recommended for overhangs up to 1 foot horizontal. The vertical clearance should be increased equally for each additional increase in horizontal overhang to a maximum vertical clearance of 6 feet.
7. Caulk all cracks, seams and joints within 6 feet horizontally as well as 6 feet above and below vent. See Figure 16.

**FIGURE 19  
MOISTURE ZONES**



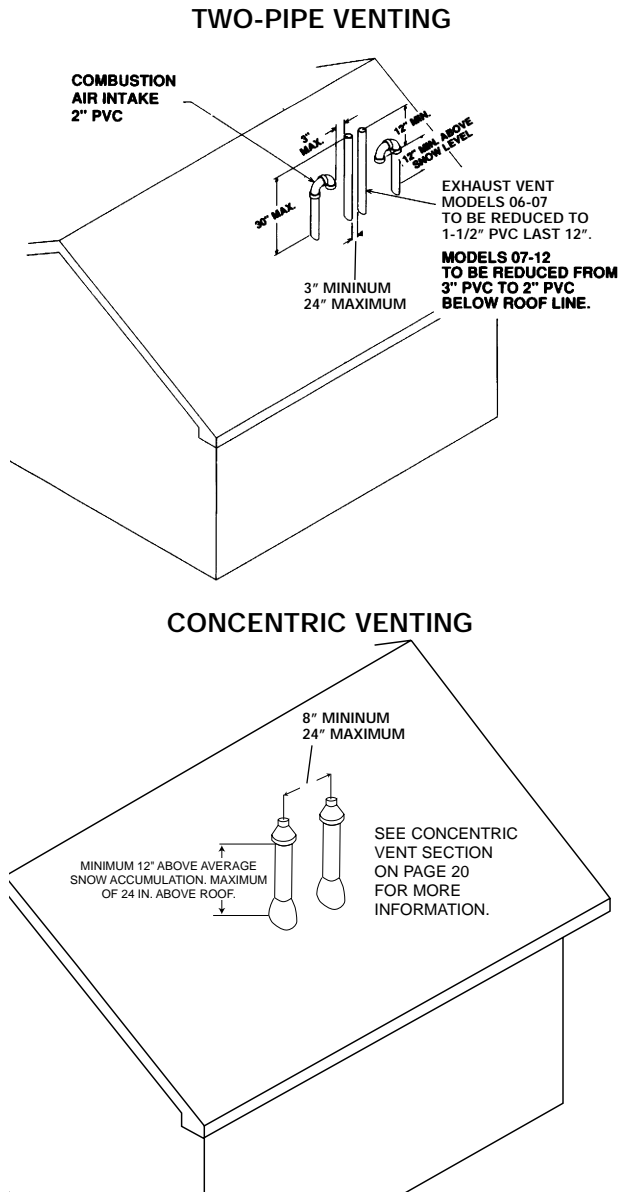
**FIGURE 20**  
**DIRECT VENT TERMINAL CLEARANCES**



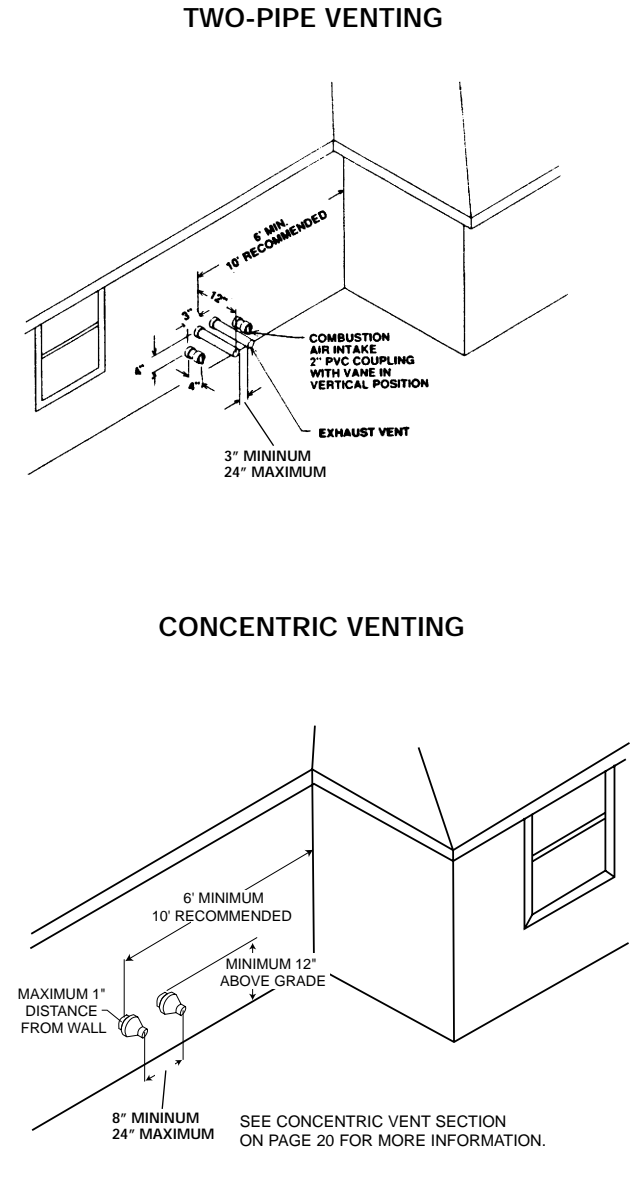
	Canadian Installations <sup>1</sup>	US Installations <sup>2</sup>	Canadian Installations <sup>1</sup>	US Installations <sup>2</sup>
A=	Clearance above grade, veranda, porch, deck, or balcony	12 inches (30 cm)	Clearance to nonmechanical air supply inlet to building or the combustion air inlet to any other appliance	6 inches (15 cm) for appliances ≤10,000 BTUH (3 kW), 9 inches (23 cm) for appliances >10,000 BTUH (3 kW) and ≤50,000 BTUH (15 kW), 36 inches (91 cm) for appliances >50,000 BTUH (15 kW)
B=	Clearance to window or door that may be opened	6 inches (15 cm) for appliances ≤10,000 BTUH (3 kW), 12 inches (30 cm) for appliances >10,000 BTUH (3 kW) and ≤50,000 BTUH (15 kW), 36 inches (91 cm) for appliances >50,000 BTUH (15 kW)	Clearance to nonmechanical air supply inlet to building or the combustion air inlet to any other appliance	6 inches (15 cm) for appliances ≤10,000 BTUH (3 kW), 12 inches (30 cm) for appliances >10,000 BTUH (3 kW) and ≤50,000 BTUH (15 kW), 36 inches (91 cm) for appliances >50,000 BTUH (15 kW)
C=	Clearance to permanently closed window	*	Clearance to a mechanical air supply inlet	6 feet (1.83 m)
D=	Vertical clearance to ventilated soffit located above the terminal within a horizontal distance of 2 feet (61 cm) from the center line of the terminal	*	Clearance above paved sidewalk or paved driveway located on public property	7 feet (2.13 m) †
E=	Clearance to unventilated soffit	*	Clearance under veranda, porch, deck, or balcony	12 inches (30 cm) ‡
F=	Clearance to outside corner	*		
G=	Clearance to inside corner	*		
H=	Clearance to each side of center line extended above meter/regulator assembly	3 feet (91 cm) within a height 15 feet above the meter/regulator assembly		
I=	Clearance to service regulator vent outlet	3 feet (1.83 m)		

<sup>1</sup> In accordance with the current CSA B149.1 Natural Gas and Propane Installation Code  
<sup>2</sup> In accordance with the current ANSI Z223.1 / NFPA 54 National Fuel Gas Code  
 † A vent shall not terminate directly above a sidewalk or paved driveway that is located between two single family dwellings and serves both dwellings.  
 ‡ Permitted only if veranda, porch, deck, or balcony is fully open on a minimum of two sides beneath the floor.  
 \* For clearances not specified in ANSI Z223.1 / NFPA 54 or CAN/CGA-B149, one of the following shall be indicated:  
 a) A reference to the following footnote:  
 "Clearance in accordance with local installation codes, the requirements of the gas supplier and the manufacturer's installation instructions."

**FIGURE 21**  
TWO FURNACE VENTING THROUGH ROOF



**FIGURE 22**  
TWO FURNACE VENTING THROUGH WALL



8. Painted surfaces must be sound and in good condition with no cracking, peeling, etc. Painted surfaces will require maintenance.
9. Do not expose 3" x 2" reducer/bushing to outdoor ambient temperatures.

**MULTIVENTING**

**IF VENTING TWO OR MORE FURNACES NEAR EACH OTHER IS REQUIRED, EACH FURNACE MUST BE INDIVIDUALLY VENTED – NO COMMON VENTING IS PERMITTED.** See Figures 18 and 19 for positioning of the terminations. When more than two furnaces are to be vented, there must be at least 4 feet between the first two furnaces and the third, etc.

**CONNECTING TO FURNACE**

**IMPORTANT:** Clean and deburr all pipe cuts. The shavings must not be allowed to block the exhaust, inlet or condensate drain pipes.

**IMPORTANT:** When indoor combustion air is used, the inlet air opening at the furnace must be protected from accidental blockage. On down-flow models, install a double elbow in the top inlet air opening. See Figure 25.

## UPFLOW MODELS

The exhaust air pipe connection is a 2-in. female PVC pipe fitting extending through the left side of the furnace top plate. See Figure 23. This opening has a protective cap which should be removed just prior to installing the exhaust pipe. When 2-in. pipe is used, connect it directly to this fitting. When 3-in. pipe is used, connect a 2 to 3-in. coupling to this fitting with a short piece of 2-in. PVC pipe.

The inlet combustion air connection is at the right side of the top plate. An alternate combustion inlet air connection may be made on the right side of the jacket. The alternate connection opening has a plastic cap. A combustion inlet air connection fitting is supplied with the furnace and it must be installed in the furnace by screwing it into the opening. Make sure the rubber "O-ring" supplied with the furnace is used with this fitting. See Figures 23 and 24.

**IMPORTANT:** When using indoor combustion air, the furnace air opening must be protected from accidental blockage. Install a 2-inch 90° elbow pointing downward on the side or a double elbow pointing downward in the top opening. See Figure 24.

### ►DOWNFLOW/HORIZONTAL MODELS

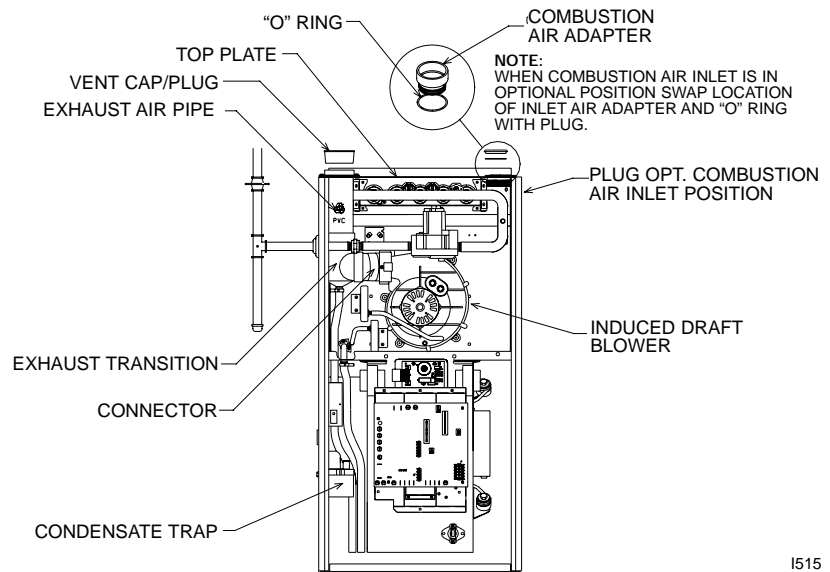
**NOTE:** Combustion air inlet and exhaust outlet air pipes are reversed for downflow from that of upflow.

The exhaust pipe connection is a 2-in. PVC pipe fitting extending through the right side of the furnace top cover. This opening has a protective cap which should be removed just prior to installing the exhaust pipe. When 2-in. pipe is used, connect it directly to this fitting. When 3-in. pipe is used, connect with a 2- to 3-in. coupling directly to the 2-in. pipe.

The combustion inlet air connection is a 2-in. extruded hole on the left side of the top plate. When a 2-in. pipe is used, attach a 2-in. PVC coupling over this hole with RTV sealant and also add two sheet metal screws through the coupling into the extrusion to secure it in place, and add the required piping. When 3-in. pipe is required, use a 2- to 3-in. coupling and add the required piping. See Figure 25

**IMPORTANT:** Always pre-drill holes before securing with screws. Using self-tapping screws without first pre-drilling causes the PVC fitting to crack.

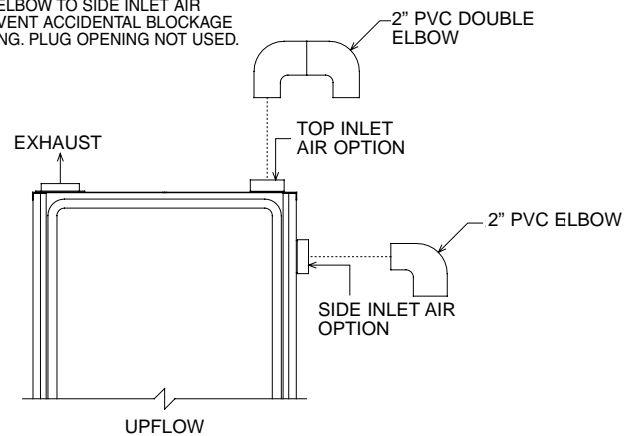
**FIGURE 23**  
UPFLOW MODELS -- COMBUSTION AIR AND VENT PIPE CONNECTION



1515

**FIGURE 24**  
UPFLOW MODELS -- COMBUSTION AIR FITTING

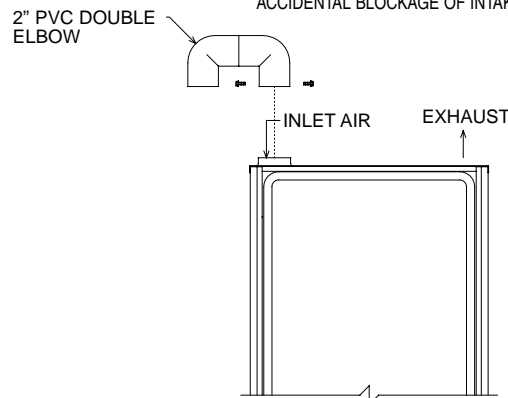
ATTACH DOUBLE ELBOW TO TOP INLET AIR OPENING OR 90° ELBOW TO SIDE INLET AIR OPENING TO PREVENT ACCIDENTAL BLOCKAGE OF INTAKE OPENING. PLUG OPENING NOT USED.



1337

**► FIGURE 25**  
DOWNFLOW/HORIZONTAL MODELS -- COMBUSTION AIR AND VENT PIPE CONNECTION

ATTACH DOUBLE ELBOW TO INTAKE AIR COLLAR AND SECURE WITH TWO SHEET METAL SCREWS TO PREVENT ACCIDENTAL BLOCKAGE OF INTAKE AIR OPENING.





# CONDENSATE DRAIN/OPTIONAL NEUTRALIZER

## GENERAL INFORMATION

### ▲ CAUTION

**DO NOT RUN DRAIN OUTDOORS. FREEZING OF CONDENSATE CAN CAUSE PROPERTY DAMAGE.**

**IMPORTANT:** Do not connect to a common drain line with an air conditioner evaporator coil drain located below the furnace. A blocked or restricted drain line can result in overflow of the coil pan and negate the furnace blocked-drain shutoff control.

► **IMPORTANT:** If installing the unit over a finished ceiling or living area, be certain to install an auxiliary condensate drain pan under the entire unit extending out under the condensate tee. With the minimum 5/2" riser for upflow models or 13/4" for downflow models installed above the tee, a blocked drain will result in overflow from the riser. If the furnace is installed in an attic, crawlspace or other area where freezing temperatures may occur, the furnace drain can freeze while shut off for long periods of time.

If required by local codes, install a condensate neutralizer cartridge in the drain line. Install cartridge in horizontal position only. Also install an overflow line if routing to a floor drain (see Figure 23). If available, install a condensate pump that is resistant to acidic water. Pumps are available from your local distributor. If pump used is not resistant to acidic water, a condensate neutralizer must be used ahead of the pump. The condensate pump must have an auxiliary safety switch to prevent operation of the furnace and resulting overflow of condensate in the event of pump failure. The safety switch must be wired through the "R" circuit only (low voltage) to provide operation in either heating or cooling modes.

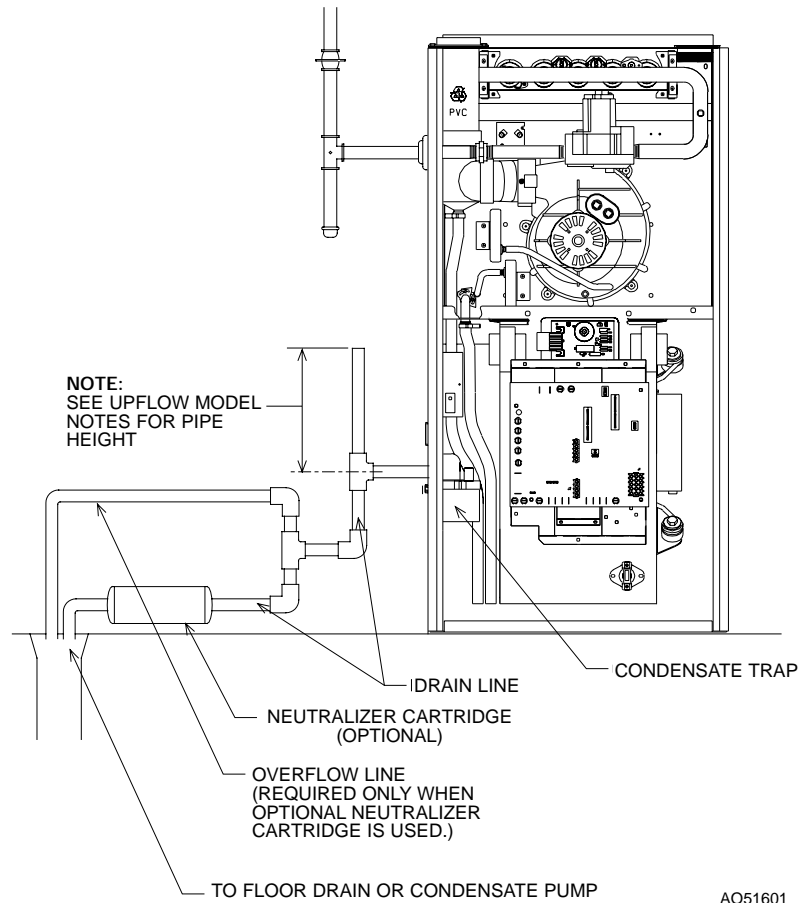
### UPFLOW MODELS

The condensate drain trap is located in the blower compartment on the left-hand side of the jacket. A short piece of 1/2-in. PVC pipe and a 1/2-in. tee are provided. Connect the 1/2-in. pipe to the elbow on the trap and the tee to this pipe so that the open end is upward. Run a drain tube from the bottom of the tee to a floor drain or condensate pump.

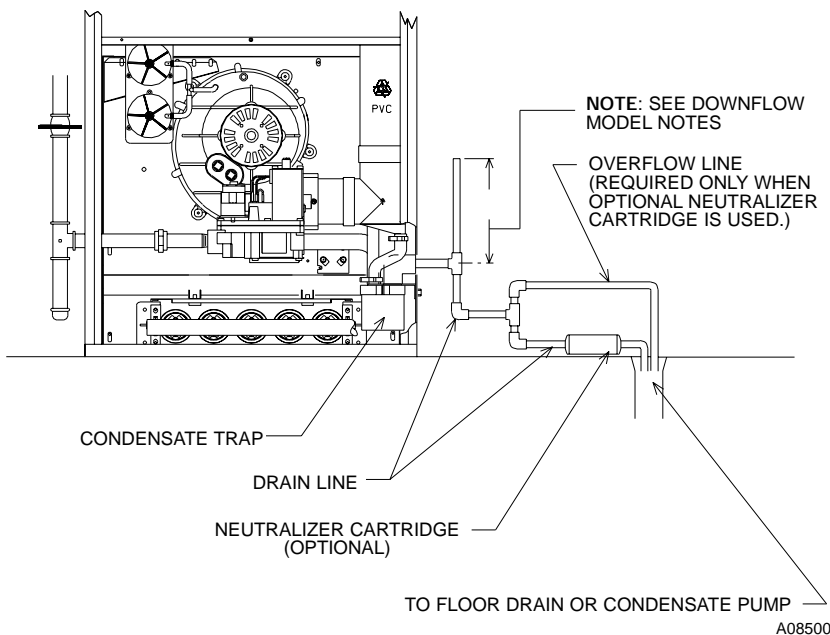
**IMPORTANT:** If installing the unit over a finished ceiling or living area, be certain to install an auxiliary condensate drain pan under the entire unit extending out under the condensate tee.

**IMPORTANT:** There are two options when choosing a height for the condensate riser:

**FIGURE 26**  
UPFLOW CONDENSATE DRAIN



► **FIGURE 27**  
DOWNFLOW CONNECTION



**CONDENSATE OVERFLOW:** With a 5½ inch riser installed above the tee, a blocked drain will result in overflow from the riser.

**FURNACE SHUTDOWN:** To cause the furnace to shut down when a blocked drain is present, install a riser which is a minimum of 10⅜". If the furnace is installed in an attic, crawlspace or other area where freezing temperatures may occur, the furnace drain can freeze while shut off for long periods of time.

Use a solvent cement that is compatible with PVC material. Cut the drain hoses to the appropriate length and connect to the trap with hose clamps. Tighten the clamps with pliers and check for leaks after attaching.

### DOWNFLOW MODELS

**IMPORTANT:** There are two options when choosing a height for the condensate riser:

**CONDENSATE OVERFLOW:** With a 1¾ inch riser installed above the tee, a blocked drain will result in overflow from the riser.

**FURNACE SHUTDOWN:** To cause the furnace to shut down when a blocked drain is present, install a riser which is a minimum of 5½". If the furnace is installed in an attic, crawlspace or other area where freezing temperatures may occur, the furnace drain can freeze while shut off for long periods of time.

Use a solvent cement that is compatible with PVC material.

### REVERSING THE TRAP UPFLOW MODELS

The trap may be moved to the right side for right side drainage. Open the knockout for the drain on the right side of the cabinet. Remove the bracket holding the trap from the left side. Seal the left side drain hole with a plug provided in the cloth bag with the furnace. Position the mounting bracket and trap so that the drain elbow is centered in the hole on the right. See Figure 28.

Drill two holes in the cabinet to mount the bracket. Mount the trap and bracket to the right side with the drain elbow pointing through the knockout. Connect the ½" pipe and tee as noted above. Route the drain hoses behind the top of the electric box, cut to the appropriate length, and connect to the trap with hose clamps.

**IMPORTANT:** Do not connect into a common drain line with an air conditioner evaporator coil drain located above the furnace. A blocked or restricted drain line can result in overflow of the coil pan and negate the furnace blocked drain shutoff control.

### ► DOWNFLOW MODELS

To convert to left side drainage, first remove the drainage hoses from the trap. Remove the trap from its mounting bracket, rotate it 180°, and mount in place with the drainage elbow pointing to the left. Reattach the drain hoses. Remove the plastic drainage knockout from the left side. See Figure 29.

**IMPORTANT:** When changing to the left side, interchange the rubber grommet on the right side with the hole plug on the left side. The hole plug must be in place to assure that the control compartment is sealed.

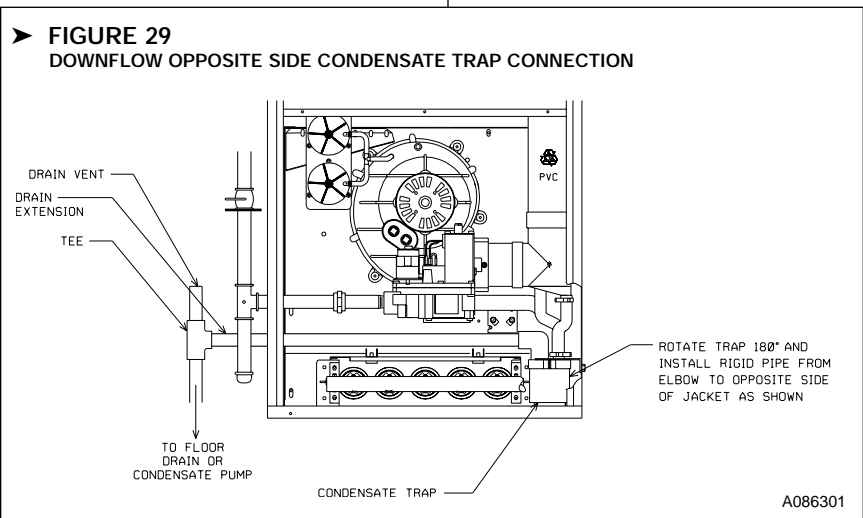
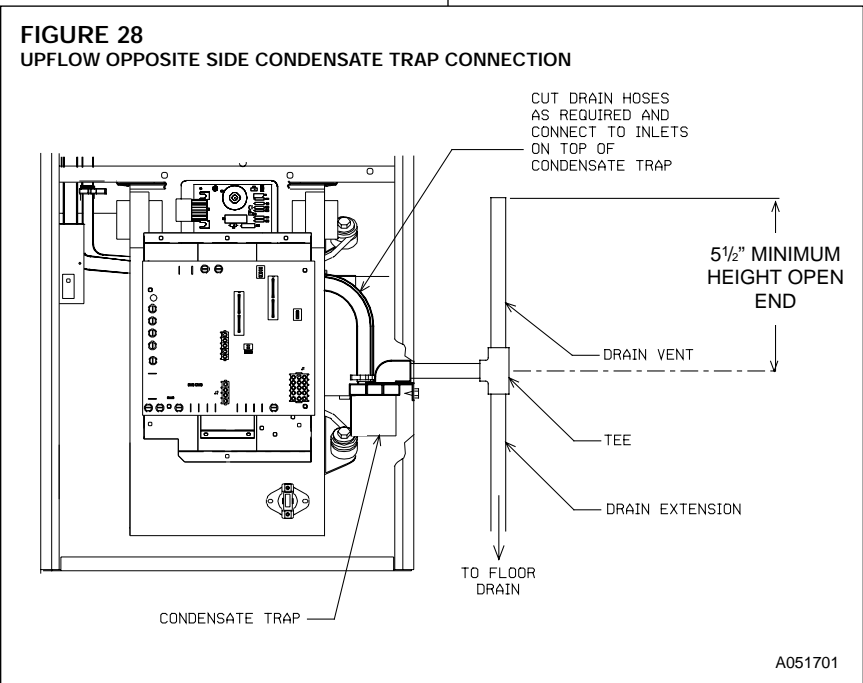
A length of ½" PVC pipe is provided for left hand drainage. Glue one end of the pipe to the elbow in the trap. Cut the pipe so that it extends through the left cabinet side one inch. Connect the ½" tee to the pipe with a 1¾" riser and drain tube as listed above. Use

the plastic plug from the left side drainage knockout to seal the right side drainage knockout.

**IMPORTANT:** Do not connect into a common drain line with an air conditioner evaporator coil drain located above the furnace. A blocked or restricted drain line can result in overflow of the coil pan and negate the furnace blocked drain shutoff control.

### FILLING THE TRAP

**FILL THE TRAP ASSEMBLY WITH WATER BEFORE OPERATING THE FURNACE.** Do this by removing the drain hose from the trap or from the connection to the secondary coil. Pour about a cup of water into the vent trap. Any excess water flows into the house drain when the trap is full.



# CONDENSATE DRAIN FOR HORIZONTAL INSTALLATION

**IMPORTANT:** When installing the -GGD furnace in the horizontal configuration, a special kit must be used to convert the furnace for horizontal installation. The necessary kits are listed here.

FURNACE MODEL	HORIZONTAL CONVERSION KIT
(-)GGD-06	RXGY-G01
(-)GGD-07	RXGY-G02
(-)GGD-09	RXGY-G03
(-)GGD-10	RXGY-G04
(-)GGD-12	RXGY-G05

Refer to Figure 31 for Steps 1-5.

1. This unit is shipped factory ready for downflow installation. The condensate trap assembly and drain hoses require conversion for horizontal installation.

Remove the existing condensate trap with the unit in the upright position.

2. Remove the burner compartment door from the unit.
3. Remove the two screws from the right side of the furnace jacket which support the trap mounting bracket ②. Remove the two plastic plugs on either side of the trap outlet hole and discard.

4. Remove the (L-shaped) clear, ribbed vinyl drain tube (3) from the top of the existing trap (1).

Do not disconnect the short end from the furnace collector box.

5. Remove the clear ribbed drain tube (4) from the existing trap (3) and the exhaust transition (5). Discard this tube. Retain the clamps for future use. Additional clamps are provided in the parts bag if any clamps are damaged during conversion process.

**NOTE:** The following steps should take place with the furnace in the horizontal position.

Refer to Figure 32 for Steps 6-11.

6. Locate the parts bag in the burner compartment. Install two plastic plugs (6) in the side of the jacket from bottom side up.

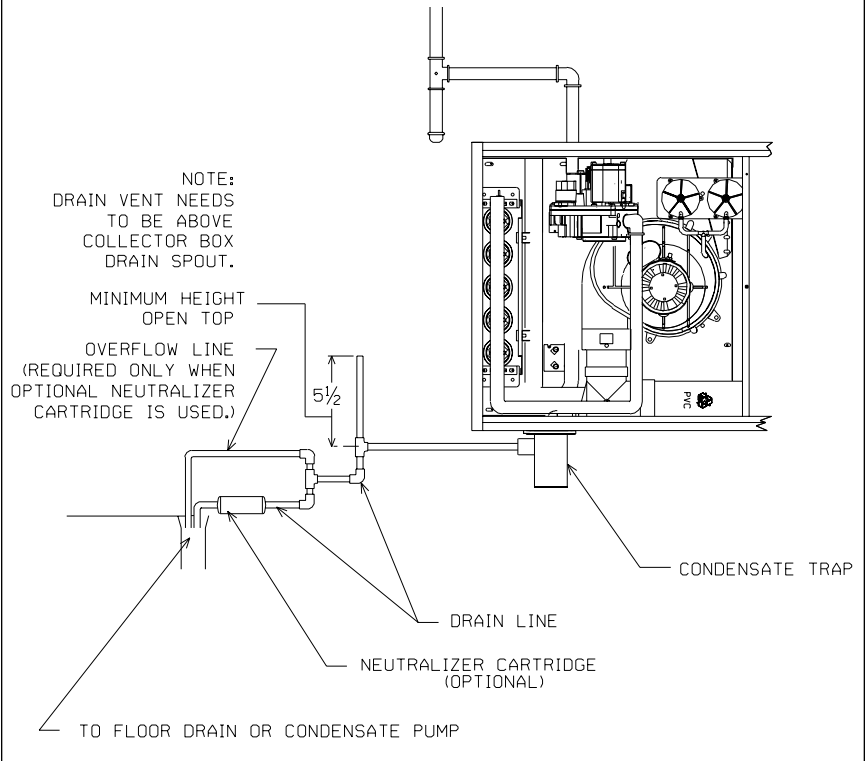
7. Fill the replacement trap assembly (7) with 1/2 cup of water.
8. Attach the self-adhesive gasket (8) onto the trap assembly so that the gasket holes on the gasket line up with the holes on the trap assembly.
9. Remove plastic plugs from the two screw holes to be used in the horizontal position (see Figure 32). Insert the trap assembly with gasket up through the existing hole in the jacket and secure from inside the jacket. Use two screws provided. Screw down into the two "ears" molded into either side of the trap. Snug the trap assembly against the furnace jacket compressing the gasket slightly to eliminate any air leaks. Do not overtighten!
10. Attach the black molded rubber 90° elbow (9) to the straight spout on the trap top using a black nylon clamp (10). Attach the other end of the rubber elbow to the spout (1) located on the exhaust transition (5) using a black nylon clamp

11. Attach the end of the ribbed tube (3) to the 45° elbow molded into the top of the trap assembly using a black nylon clamp.

**IMPORTANT:** Tighten all clamp connections with a pair of pliers and check for leaks after conversion is complete.

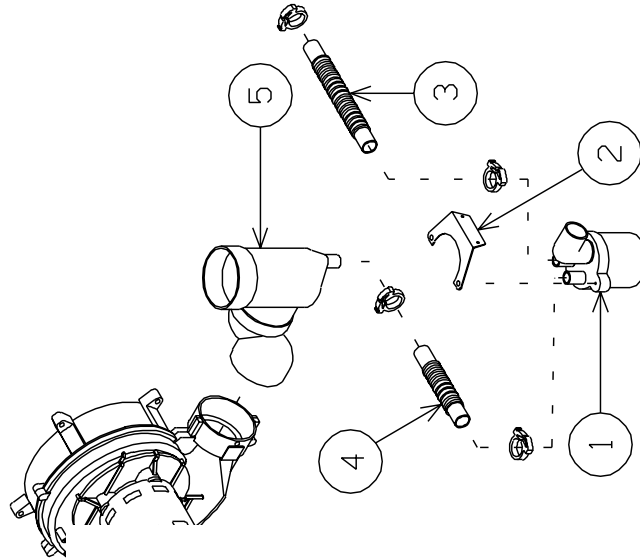
12. Connect a 5/2" riser to the top of the tee and run a drain tube from the bottom of the tee to a floor drain or condensate pump. Use a solvent cement that is compatible with PVC material.

**FIGURE 30**  
HORIZONTAL CONDENSATE DRAIN



# CONDENSATE TRAP CONVERSION FROM DOWNFLOW TO HORIZONTAL INSTALLATION

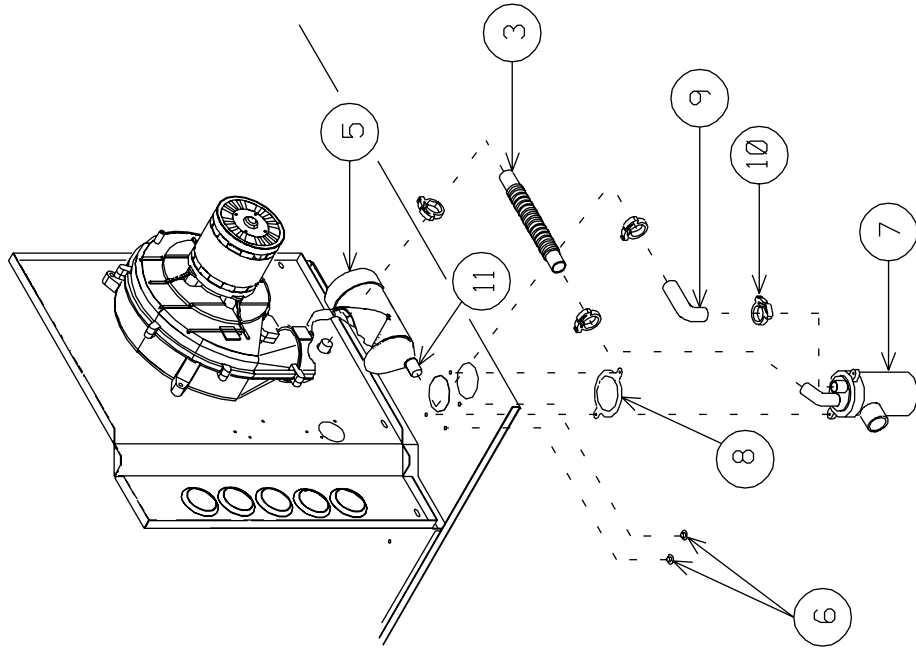
**FIGURE 31**  
UPRIGHT POSITION: REMOVAL OF EXISTING DOWNFLOW CONDENSATE TRAP



ST-A0872-01

I534.DGN

**FIGURE 32**  
HORIZONTAL POSITION: CONDENSATE TRAP INSTALLATION FOR HORIZONTAL OPERATION



# GAS SUPPLY AND PIPING

## GAS SUPPLY

### ⚠ WARNING

THIS FURNACE IS EQUIPPED AT THE FACTORY FOR USE ON NATURAL GAS ONLY. CONVERSION TO LP GAS REQUIRES A SPECIAL KIT SUPPLIED BY THE DISTRIBUTOR OR MANUFACTURER. MAILING ADDRESSES ARE LISTED ON THE FURNACE RATING PLATE, PARTS LIST AND WARRANTY. FAILURE TO USE THE PROPER CONVERSION KIT CAN CAUSE FIRE, CARBON MONOXIDE POISONING, EXPLOSION, PROPERTY DAMAGE, PERSONAL INJURY OR DEATH.

See the conversion kit index supplied with the furnace. This index identifies the proper LP Gas Conversion Kit required for each particular furnace.

**IMPORTANT:** Any additions, changes or conversions required for the furnace to satisfactorily meet the application should be made by a qualified installer, service agency or the gas supplier, using factory-specified or approved parts.

**IMPORTANT:** Connect this furnace only to gas supplied by a commercial utility.

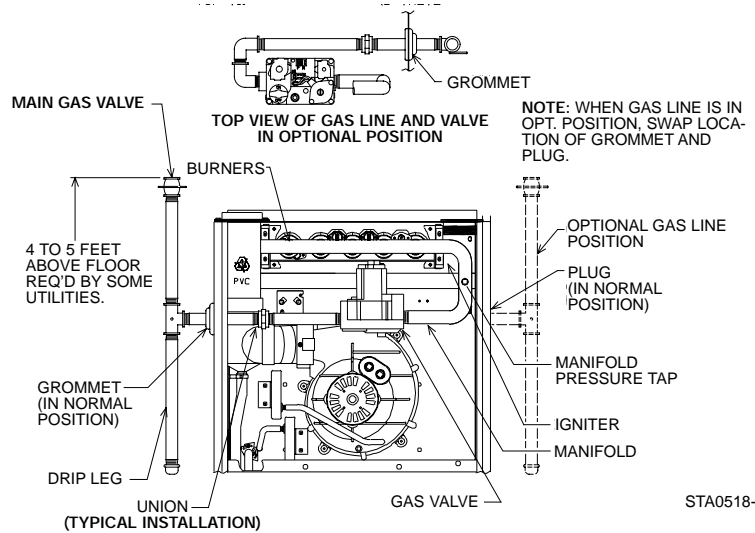
**IMPORTANT:** A U.L. recognized fuel gas and CO detector(s) are recommended in all applications, and their installation should be in accordance with the manufacturer's recommendations and/or local laws, rules, regulations or customs.

## GAS PIPING

Install the gas piping according to all local codes and regulations of the utility company.

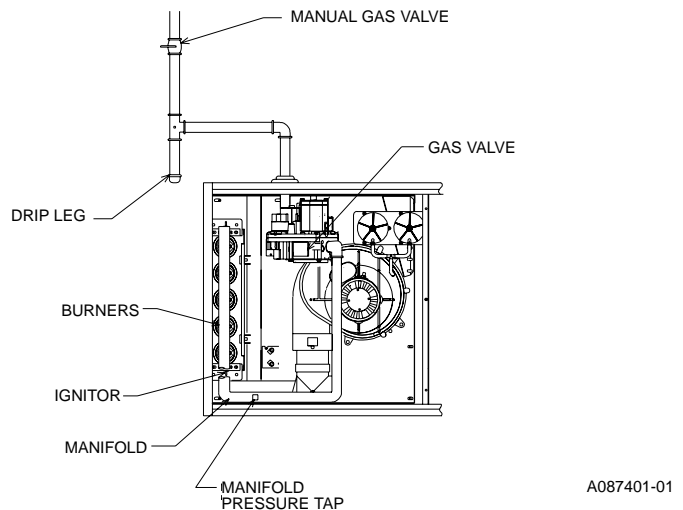
If possible, run a separate gas supply line directly from the meter to the furnace. Consult the local gas company for the location of the manual main shut-off valve. The gas line and manual gas valve must be adequate in size to prevent undue pressure drop and never smaller than the pipe size

**FIGURE 33**  
GAS PIPING -- UPFLOW INSTALLATION

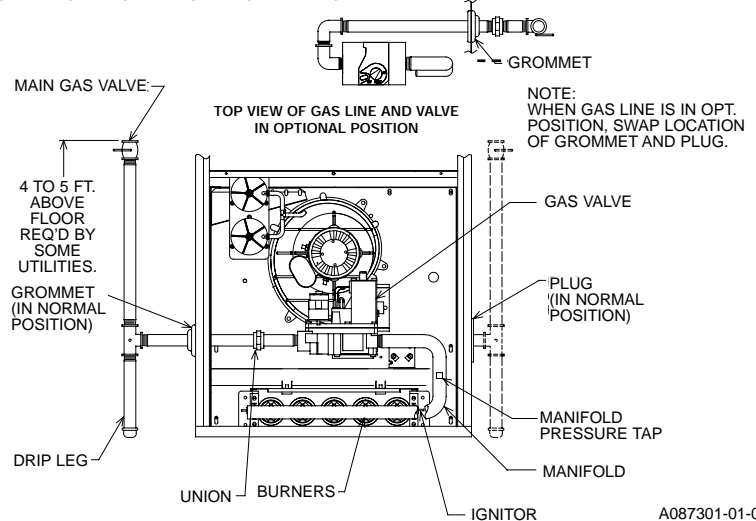


**IMPORTANT:** Do not run a flexible gas connector inside the unit.

➤ **FIGURE 34**  
GAS PIPING -- HORIZONTAL INSTALLATION



➤ **FIGURE 35**  
GAS PIPING -- DOWNFLOW INSTALLATION



to the combination gas valve on the furnace. Refer to Table 8 for the recommended gas pipe size for natural gas and Table 9 for L.P. See Figures 27 & 28 for typical gas pipe connections.

**Install a ground joint union inside the cabinet to easily remove the control valve assembly. Install a manual shut-off valve in the gas line outside the furnace casing.** The valve should be readily accessible to turn the gas supply on or off. Install a drip leg in the gas supply line as close to the furnace as possible. Always use a pipe compound resistant to the action of liquefied petroleum gases on all threaded connections.

**IMPORTANT:** When making gas pipe connections, use a back-up wrench to prevent any twisting of the control assembly and gas valve.

Any strains on the gas valve can change the position of the gas orifices in the burners. This can cause erratic furnace operation.

**IMPORTANT:** Do not run a flexible gas connector inside the unit. If local codes allow the use of a flexible gas appliance connector, always use a new listed connector. Do not use a connector which has previously serviced another gas appliance. Massachusetts law requires that all flexible gas connectors be less than 36".

The gas pipe grommet in the cabinet does not seal around a flexible gas connector. **It is important to have all openings in the cabinet burner compartment sealed for proper furnace operation.**

**IMPORTANT:** Ensure that the furnace gas control valve is not subjected to high gas line supply pressures (13.5" w.c. or above).

**DISCONNECT** the furnace and its individual shut-off valve from the gas supply piping during any pressure testing that exceeds 1/2 PSIG (3.23 kPa or 13" w.c.).

## GAS PRESSURE

**Natural gas supply pressure should be 5" to 10.5" w.c. LP gas supply pressure should be 11" to 13" w.c. This pressure must be maintained with all other gas-fired appliances in operation.**

The minimum supply pressure to the gas valve for proper furnace input adjustments is 5" w.c. for natural gas, however 6" to 7" is recommended. The minimum supply pressure is 10.5" w.c. for LP gas.

### **▲ WARNING**

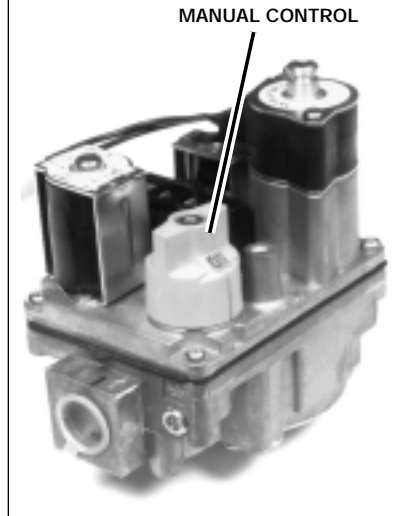
**NEVER PURGE A GAS LINE INTO THE COMBUSTION CHAMBER. NEVER USE MATCHES, FLAME OR ANY IGNITION SOURCE FOR CHECKING LEAKAGE. FAILURE TO ADHERE TO THIS WARNING CAN CAUSE A FIRE OR EXPLOSION RESULTING IN PROPERTY DAMAGE, PERSONAL INJURY OR DEATH.**

To check for gas leakage, use an approved chloride-free soap and water solution, an electronic combustible gas detector, or other approved method.

## GAS VALVE

This furnace has a 24-volt operated valve. It has ports for measuring supply pressure and manifold pressure. A manual control is on the valve body. It can be set to only the "ON" or "OFF" positions. See Figure 36.

**FIGURE 36**  
GAS VALVE



**TABLE 8****NATURAL GAS PIPE CAPACITY TABLE (CU. FT./HR.)**

Capacity of gas pipe of different diameters and lengths in cu. ft. per hr. with pressure drop of 0.3 in. and specific gravity of 0.60 (natural gas).

Nominal Iron Pipe Size, Inches	Length of Pipe, Feet							
	10	20	30	40	50	60	70	80
1/2	132	92	73	63	56	50	46	43
3/4	278	190	152	130	115	105	96	90
1	520	350	285	245	215	195	180	170
1-1/4	1,050	730	590	500	440	400	370	350
1-1/2	1,600	1,100	890	760	670	610	560	530

After the length of pipe has been determined, select the pipe size which will provide the minimum cubic feet per hour required for the gas input rating of the furnace. By formula:

$$\text{Cu. Ft. Per Hr. Required} = \frac{\text{Gas Input of Furnace (BTU/HR)}}{\text{Heating Value of Gas (BTU/FT}^3\text{)}}$$

The gas input of the furnace is marked on the furnace rating plate. The heating value of the gas (BTU/FT<sup>3</sup>) may be determined by consulting the local natural gas utility or the LP gas supplier.

**TABLE 9****LP GAS PIPE CAPACITY TABLE (CU. FT./HR.)**

Maximum capacity of pipe in thousands of BTU per hour of undiluted liquefied petroleum gases (at 11 inches water column inlet pressure).

(Based on a Pressure Drop of 0.5 Inch Water Column)

Nominal Iron Pipe Size, Inches	Length of Pipe, Feet											
	10	20	30	40	50	60	70	80	90	100	125	150
1/2	275	189	152	129	114	103	96	89	83	78	69	63
3/4	567	393	315	267	237	217	196	182	173	162	146	132
1	1,071	732	590	504	448	409	378	346	322	307	275	252
1-1/4	2,205	1,496	1,212	1,039	913	834	771	724	677	630	567	511
1-1/2	3,307	2,299	1,858	1,559	1,417	1,275	1,181	1,086	1,023	976	866	787
2	6,221	4,331	3,465	2,992	2,646	2,394	2,205	2,047	1,921	1,811	1,606	1,496

Example (LP): Input BTU requirement of unit, 150,000  
Equivalent length of pipe, 60 ft. = 3/4" IPS required.

**LP COPPER TUBE SIZING TABLE**

Sizing between single or second stage (low pressure) regulator and appliance. Maximum capacity of pipe in thousands of BTU per hour of undiluted propane gases (at 11" w.c. setting).

Outside Diameter Copper Tubing, Type L	Length of Pipe, Feet									
	10	20	30	40	50	60	80	100	125	150
3/8"	49	34	27	23	20	19	16	14	11	10
1/2"	110	76	61	52	46	42	36	32	28	26
5/8"	206	141	114	97	86	78	67	59	52	48
3/4"	348	239	192	164	146	132	113	100	89	80
7/8"	536	368	296	253	224	203	174	154	137	124

## LP CONVERSION

**IMPORTANT:** LP gas from trucks used to transport liquid-based fertilizers can contain chemicals that will damage the furnace. Verify that your gas supplier does not use the same truck to transport materials other than LP.

This furnace is shipped from the factory for use on natural gas only. For use on LP gas, a proper conversion is required.

Conversion of this furnace for use on LP gas requires conversion kit **RXGJ-FP07** for U.S. and **RXGJ-FP08** for Canada. This kit includes an LP gas valve.

### **▲ CAUTION**

**ELEVATIONS ABOVE 2000 FT REQUIRE THAT THE FURNACE INPUT RATING BE ADJUSTED AND THAT THE SIZE OF THE BURNER ORIFICES BE RE-CALCULATED BASED ON ELEVATION AND GAS HEATING VALUE. THE BURNER ORIFICES MAY (OR MAY NOT) NEED TO BE CHANGED. SEE THE SECTION TITLED "HIGH ALTITUDE INSTALLATIONS" OF THIS BOOK FOR INSTRUCTIONS.**

**NOTE:** Order the correct LP conversion kit from the furnace manufacturer. *Furnace conversion to LP gas must be performed by a qualified installer, service agency, or the gas supplier.*

To change orifice spuds for either conversion to LP or for elevation:

1. Shut off the manual gas valve and disconnect the gas line at the union ahead of the unit gas valve.

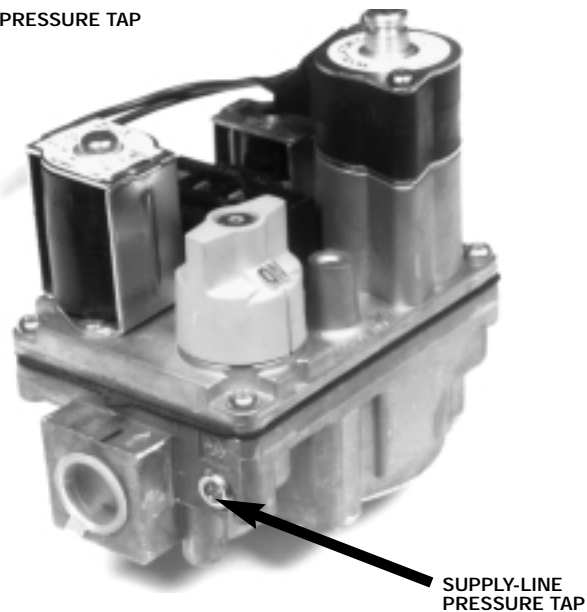
2. Remove the gas valve and manifold assembly.
3. Replace the orifice spuds.
4. Remove the natural gas valve from the manifold assembly and replace with the LP valve included in the kit.
5. Re-attach the manifold assembly to the unit and connect the gas line to the gas valve.
6. Place the conversion label, included in the kit, adjacent to the CSA rating plate.

7. Check unit for leaks
8. Follow lighting instructions to put the furnace into operation.

Consult Table 11, if there is any question concerning orifice sizing.

**NOTE:** No LP orifices are included in the kit. LP orifices must be selected based on the altitude of the installation. See orifice chart.

**FIGURE 37**  
SUPPLY-LINE PRESSURE TAP





## SETTING GAS PRESSURE

A properly calibrated pressure gauge or U-Tube manometer is required for accurate gas pressure measurements.

### ▲ CAUTION

ELEVATIONS ABOVE 2000 FT REQUIRE THAT THE FURNACE INPUT RATING BE ADJUSTED AND THAT THE SIZE OF THE BURNER ORIFICES BE RE-CALCULATED BASED ON ELEVATION AND GAS HEATING VALUE. THE BURNER ORIFICES MAY (OR MAY NOT) NEED TO BE CHANGED. SEE THE SECTION TITLED "HIGH ALTITUDE INSTALLATIONS" OF THIS BOOK FOR INSTRUCTIONS.

Supply Gas Pressure Measurement.

1. With gas shut off to the furnace at the manual gas valve outside the unit, remove the line pressure tap plug on the gas valve. See Figure 30.

2. Connect a U-Tube manometer to the pressure tap.
3. Turn on the gas supply and operate the furnace at 100% and all other gas-fired units on the same gas line as the furnace.
4. Note or adjust the supply-line pressure to give:
  - A. 5" - 10.5" w.c. for natural gas.
  - B. 11" - 13" w.c. for LP gas.
5. Shut off the gas at the manual gas valve and remove the U-Tube manometer.
6. Replace the supply-line pressure tap plug before turning on the gas.

If the supply-line pressure is above these ranges, install an in-line gas regulator to the furnace for natural gas units. With LP gas, have the LP supplier reduce the supply-line pressure at the regulator.

If supply-line pressure is below these ranges, either remove any restrictions

in the gas supply piping or enlarge the gas pipe. See Tables 8 and 9. With LP gas, have the LP supplier adjust the supply-line pressure at the regulator.

### ▲ CAUTION

ELEVATIONS ABOVE 2000 FT REQUIRE THAT THE FURNACE INPUT RATING BE ADJUSTED AND THAT THE SIZE OF THE BURNER ORIFICES BE RE-CALCULATED BASED ON ELEVATION AND GAS HEATING VALUE. THE BURNER ORIFICES MAY (OR MAY NOT) NEED TO BE CHANGED. SEE THE SECTION TITLED "HIGH ALTITUDE INSTALLATIONS" OF THIS BOOK FOR INSTRUCTIONS.

### ► MANIFOLD GAS PRESSURE MEASUREMENT.

1. With the gas to the unit shut off at the manual gas valve, remove the outlet pressure tap plug in the gas valve. See Figure 31.
2. Connect the positive pressure hose to the pressure tap.
3. Note the manifold gas pressure to be:
  - A. 3.5" w.c. ( $\pm$ .3) for natural gas .
  - B. 10.0" w.c. ( $\pm$ .5) for LP gas.

4. To adjust the pressure regulator, remove the regulator cap.

**NOTE:** Only small variations in gas pressure should be made by adjusting the pressure regulator.

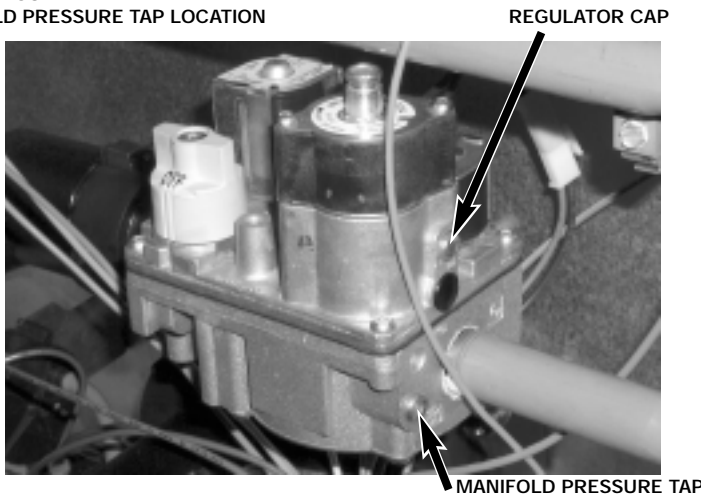
5. Turn the adjustment screw, using a  $\frac{3}{32}$ " allen wrench, clockwise to increase pressure, or counter-clockwise to decrease pressure. See Figure 32.
6. Check manifold gas pressure.
7. Repeat step 5 & 6 if needed.
8. Securely replace the regulator cap.

**NOTE:** Shut off gas at the manual gas valve and remove the U-Tube manometer.

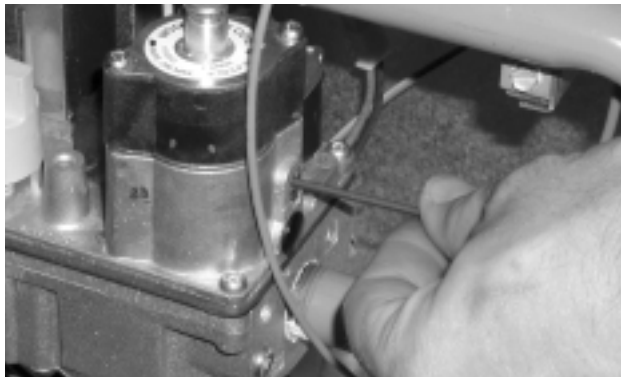
9. Replace the manifold pressure tap plug before turning on the gas.

**NOTE:** Do not use gas valve pressure adjustment as a means to adjust temperature rise. The blower motor will change speed to maintain a reasonably constant temperature rise.

**FIGURE 38**  
MANIFOLD PRESSURE TAP LOCATION



**FIGURE 39**  
GAS VALVE PRESSURE ADJUSTMENT (3/32" ALLEN WRENCH)



# ELECTRICAL WIRING

## ▲ WARNING

**TURN OFF ELECTRIC POWER AT FUSE BOX OR SERVICE PANEL BEFORE MAKING ANY ELECTRICAL CONNECTIONS. FAILURE TO DO SO CAN CAUSE ELECTRICAL SHOCK RESULTING IN PERSONAL INJURY OR DEATH.**

## ▲ WARNING

**THE CABINET MUST HAVE AN UNINTERRUPTED GROUND ACCORDING TO THE LATEST EDITION OF THE NATIONAL ELECTRICAL CODE, ANSI/NFPA70-, OR IN CANADA, THE CANADIAN ELECTRICAL CODE, CSA-C22.1 OR LOCAL CODES THAT APPLY. A GROUND SCREW IS PROVIDED IN THE JUNCTION BOX. FAILURE TO PROPERLY CONNECT THE GROUND WIRE CAN CAUSE ELECTRICAL SHOCK RESULTING IN PERSONAL INJURY OR DEATH.**

## ▲ WARNING

**THIS FURNACE IS EQUIPPED WITH A BLOWER DOOR SAFETY SWITCH. DO NOT DISABLE THIS SWITCH. FAILURE TO FOLLOW THIS WARNING CAN RESULT IN ELECTRICAL SHOCK, PERSONAL INJURY OR DEATH.**

**IMPORTANT:** The furnace must be installed so that the electrical components are protected from water (condensate).

A grounding wire is provided to connect to the incoming grounding wire from line power. The furnace must be permanently grounded in accordance with all national and local codes.

Before proceeding with the electrical connections, be certain that the service panel voltage, frequency and phase corresponds to that specified on the furnace rating plate. Maximum over-current protection is 15 amperes.

Use a separate, fused branch electrical circuit containing a properly sized fuse or circuit breaker. Run this circuit directly from the main switch box to an electrical disconnect that is readily accessible and located near the furnace. Connect from

the electrical disconnect to the junction box on the left side of the furnace, inside the blower compartment. See Figure 33. For the proper connection, refer to the appropriate wiring diagram located on the inside cover of the furnace control box and in these instructions.

**NOTE:** The electrical junction box may be moved to the right side if necessary. A knockout is provided. Seal the opposite hole with plug provided.

**IMPORTANT:** 120 vac terminal and neutral terminal polarity must be observed when making field connections to the furnace. The ignition control WILL not sense flame if 120 vac and neutral terminals reversed.

Make all electrical connections in accordance with the latest edition of the National Electrical Code ANSI/NFPA70 – or in Canada, the Canadian Electrical Code Part 1- CSA Standard C22.1 and local codes having jurisdiction.

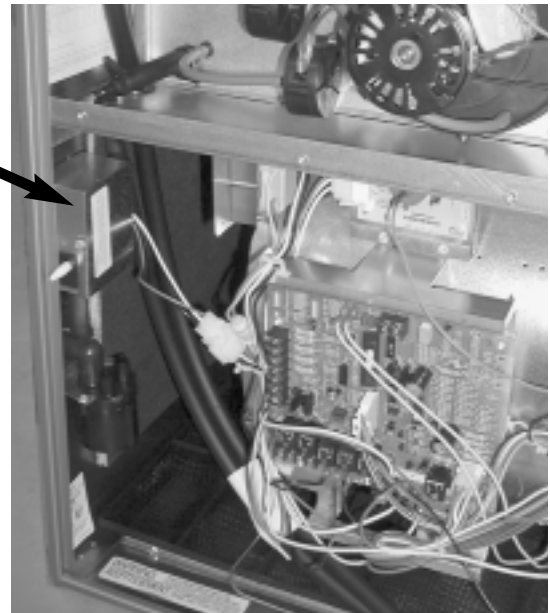
These may be obtained from:

National Fire Protection  
Association, Inc.  
Batterymarch Park  
Quincy, MA 02269

Canadian Standards Association  
178 Rexdale Boulevard  
Rexdale, Ontario, Canada M9W 1R3

**FIGURE 40**  
JUNCTION BOX LOCATION

UPFLOW  
MODELS



▶ DOWNFLOW/  
HORIZONTAL  
MODELS



## ELECTRICAL CHECKS

### Line Power Check

The furnace must have a nominal 115 volt power supply for proper operation. If there is not a consistent power supply, contact a licensed electrician to correct the problem.

1. With the blower compartment door off, manually hold the push button door switch in.
2. Call for heat at the thermostat.
3. With the unit operating, use a voltmeter to measure the voltage from any 120 VAC terminal to any neutral connection.
4. The voltage should be a nominal 115 volts (acceptable 105-120VAC).

This test should be made with the unit in full operation.

### Polarity Check

Proper line voltage polarity, or phasing, is a must for this furnace to operate. Use a volt meter to make this check.

1. With the blower compartment door off, manually hold the push button door switch in.
2. Use a voltmeter to measure the voltage from any 120 VAC terminal to any bare metal ground on the furnace.
3. The voltage should be a nominal 115 volts (acceptable 105-120VAC).
4. Use a voltmeter to measure the voltage from any neutral terminal to the bare metal ground on the furnace.
5. The voltage should be approximately (0) volts.
6. If the voltage from any 120 VAC terminal to ground is approximately zero (0) volts and the voltage from a neutral to ground is a nominal 115 volts, the polarity is reversed.
7. To correct the problem, either reverse the hot and neutral wires to the furnace or have a licensed electrician check the building wiring.

### Control Voltage Check

1. With the blower compartment door off, manually hold the push button door switch in.
2. Call for heat at the thermostat.
3. With the unit operating, use a voltmeter to measure the voltage from control voltage terminal "W" to terminal "C" on the furnace control board.
4. The voltage should be a nominal 24 volts (Acceptable 105-120VAC).

This test should be made with the unit in full operation.

## THERMOSTAT WIRING

**NOTE:** Do not use 24 volt control wire smaller than No. 18 AWG.

Wire all thermostats to the 24V connections on the integrated furnace control. See Figures 34, 35, and 36.

**NOTE:** A larger wire gage may be required for longer lengths of thermostat wire.

For proper installation of the Variable Output Thermostat, follow the "Thermostat Installation, Programming and Troubleshooting Manual" included as section II of this manual. For proper installation of a Single-Stage or Two-Stage Thermostat, see the Installation Instructions included with the thermostat.

### ► FURNACE OPERATION USING MODULATING, SINGLE-STAGE, AND TWO-STAGE THERMOSTATS

The modulating furnace with the UT Electronic Controls IFC is also capable of operating with a single-stage or a two-stage thermostat as well as the modulating thermostat. Furnaces equipped with part # 62-24174-01 (rev -02 or newer) or 62-24174-02 (all revisions) will operate with either single-stage or two-stage thermostats as a modulating system using an algorithm that utilizes three distinct firing rates; 40%, 65% and 100% of the furnace heating capacity (See below for operation of each).

Figures 42, 43, and 44 detail how to wire the modulating furnace for operation with a modulating thermostat, a single-stage thermostat and a two-stage thermostat respectively.

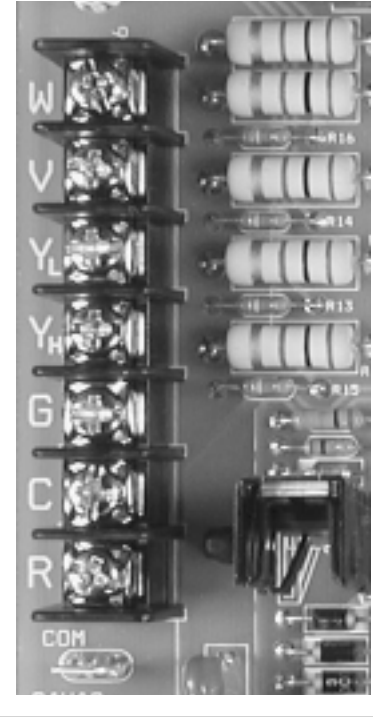
### ► FURNACE OPERATION WITH A MODULATING THERMOSTAT

As described previously in this manual, operation with a modulating thermostat when installed as shown in Figure 42 is fully modulating between 40% and 100% of furnace capacity. The firing rate is first determined by the thermostat and then sent to the furnace. This is the optimum mode of operation and will give the best temperature control with minimal temperature variation from the desired set point.

### ► FURNACE OPERATION WITH A SINGLE STAGE THERMOSTAT

To operate the furnace with a single-stage thermostat, set switches 1 & 2 of SW2 (See Figure 47) to the "OFF" position. Note that these switches should be in the "OFF" position from the factory. The lack of the modulating "V" signal will automatically be sensed as a single-stage thermostat and the furnace will operate accordingly.

**FIGURE 41**  
24-VOLT TERMINALS



With a single stage thermostat (installed as shown in Figure 43), during a call for heat, the furnace will operate as follows:

**Phase 1:** 0 to 5 minutes = 40% of furnace capacity

**Phase 2:** 5 to 12 minutes = 65% of furnace capacity

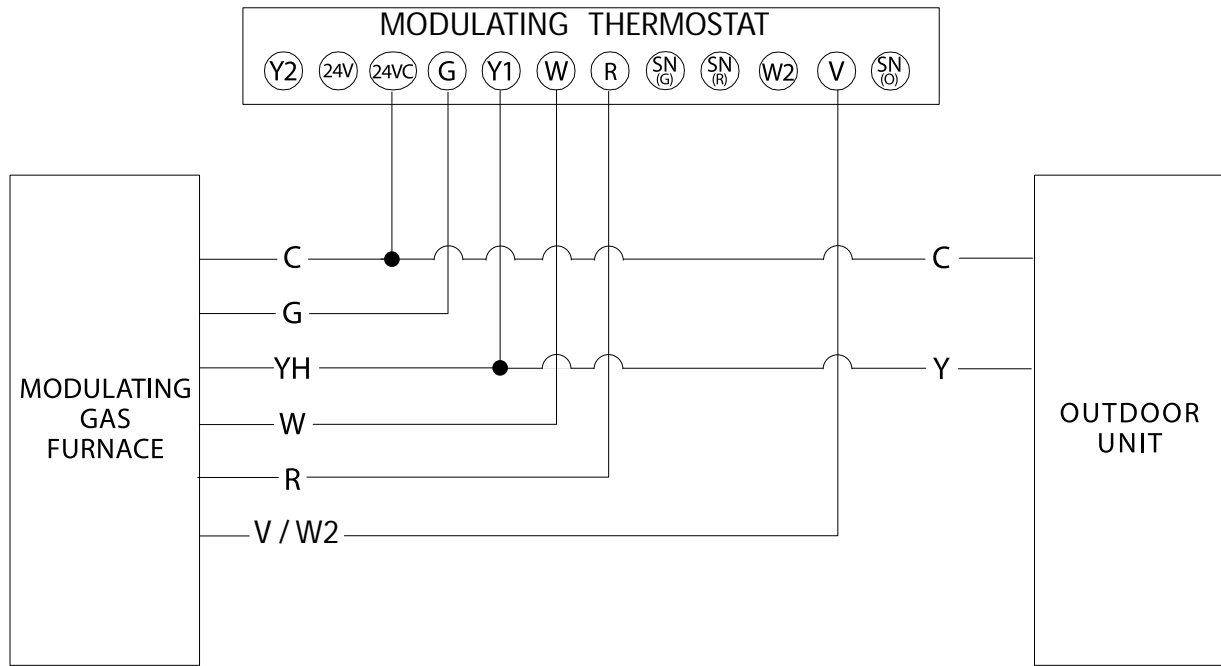
**Phase 3:** After 12 minutes = 100 % of furnace capacity

**NOTE:** If the call for heat ends during any phase, the furnace will terminate immediately at the firing rate of that phase.

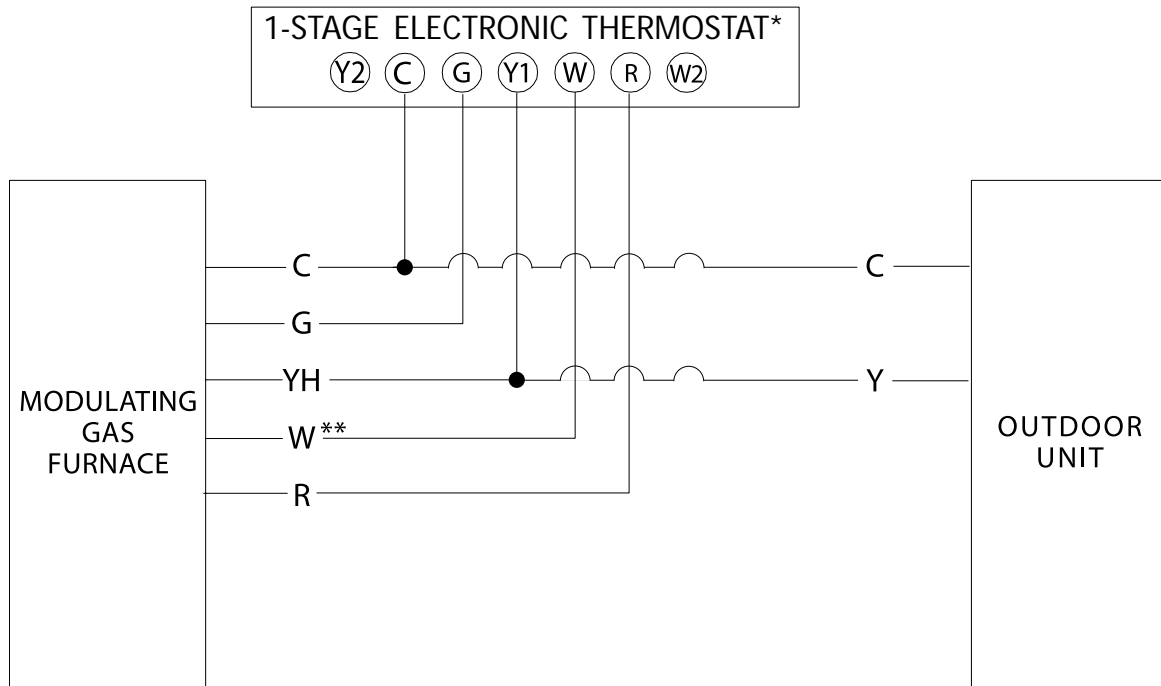
If switches 1 & 2 of SW2 are in the "ON" position (See Figure 47), the furnace will always operate at 40% with a single stage thermostat installed as shown in Figure 36.

**THIS CONFIGURATION IS NEITHER RECOMMENDED NOR APPROVED.**

**FIGURE 42**  
WIRING DIAGRAM FOR MODULATING HEAT



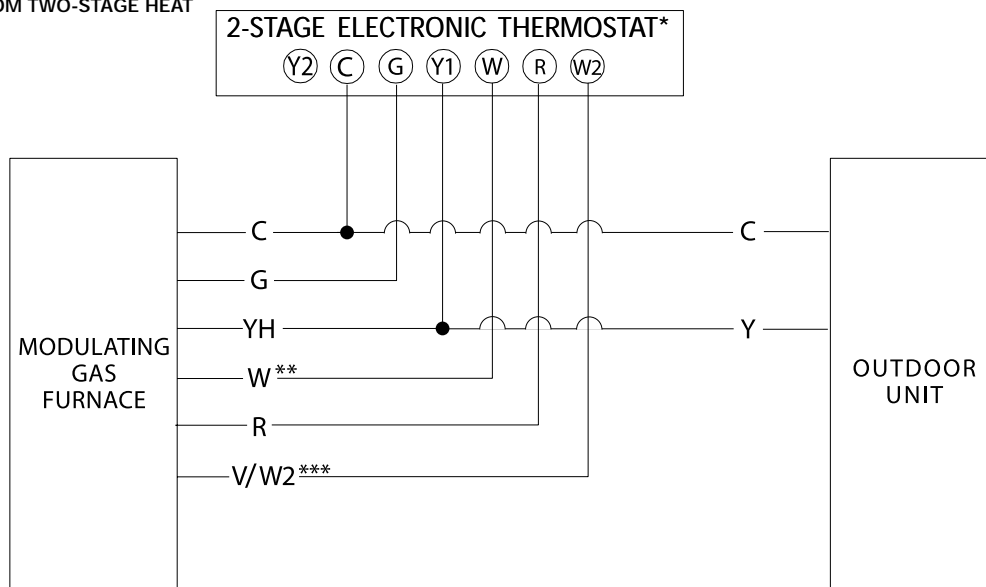
**FIGURE 43**  
WIRING DIAGRAM FOR SINGLE-STAGE HEAT



\* NO MECHANICAL THERMOSTATS.

\*\* 40%, 65%, and 100% FIRING RATE IN SINGLE-STAGE OPERATION. 40% FIRING RATE IN TWO-STAGE OPERATION (DIP SWITCH SET SW2 — SWITCHES 1 & 2 ON).

**FIGURE 44**  
WIRING DIAGRAM FROM TWO-STAGE HEAT



- \* NO MECHANICAL THERMOSTATS.
- \*\* 40%, 60%, and 100% FIRING RATE IN SINGLE-STAGE OPERATION. 40% FIRING RATE IN TWO-STAGE OPERATION (DIP SWITCH SET SW2 — SWITCHES 1 & 2 ON).
- \*\*\* 65% and 100% FIRING RATE IN TWO-STAGE OPERATION (W & W2 ENERGIZED).

### FURNACE OPERATION WITH A TWO-STAGE THERMOSTAT

To set the furnace for operation with two-stage thermostats, set switches 1 & 2 of SW2 to the "ON" position (See Figure 47). Note that these switches should be in the "OFF" position from the factory. With both switches in the "ON" position, the furnace can still recognize a "V" signal present and will still operate with a modulating thermostat. However, with both switches of SW2 in the "ON" position, the furnace is set to operate with a two-stage thermostat as well.

With a two-stage thermostat (installed as shown in Figure 44) and switch settings configured as described above, during a call for heat, the furnace will operate as follows:

#### First Stage

("W"=ON and "W2"=OFF)

40% of furnace capacity always

#### Second Stage

("W"=ON and "W2"=ON)

**Phase 1:** 0 to 5 minutes = 65% of furnace capacity

**Phase 2:** After 5 minutes = 100% of furnace capacity

**NOTE:** If the call for heat ends during any phase and/or stage, the furnace will terminate immediately at the firing rate of that phase and/or stage.

## ACCESSORIES

### FIELD-INSTALLED OPTION ACCESSORIES

#### ELECTRONIC AIR CLEANER

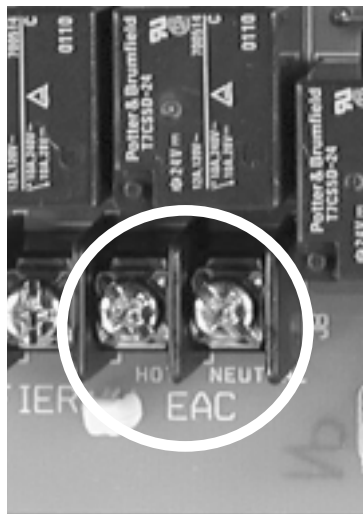
Line voltage power can be supplied from the screw terminal "EAC", see Figure 45, and a line voltage neutral screw terminal on the control board. This will power the electronic air cleaner whenever the ECM2+ blower is operating and delivering the recommended minimum CFM. The 60 and 75 KBTU models, which are capable of a maximum delivery of 1200

CFM, will operate the electronic air cleaner at 500 CFM and above. The 90, 105 and 120 KBTU models, which are capable of a maximum delivery of 2000 CFM, will operate the electronic air cleaner at 800 CFM and above. These limits are set to prevent excessive production of ozone at the lower airflows of the modulating furnace and are based on average requirements of commercially available electronic air cleaners. The continuous fan speeds are set to always provide adequate airflow for electronic air cleaner operation.

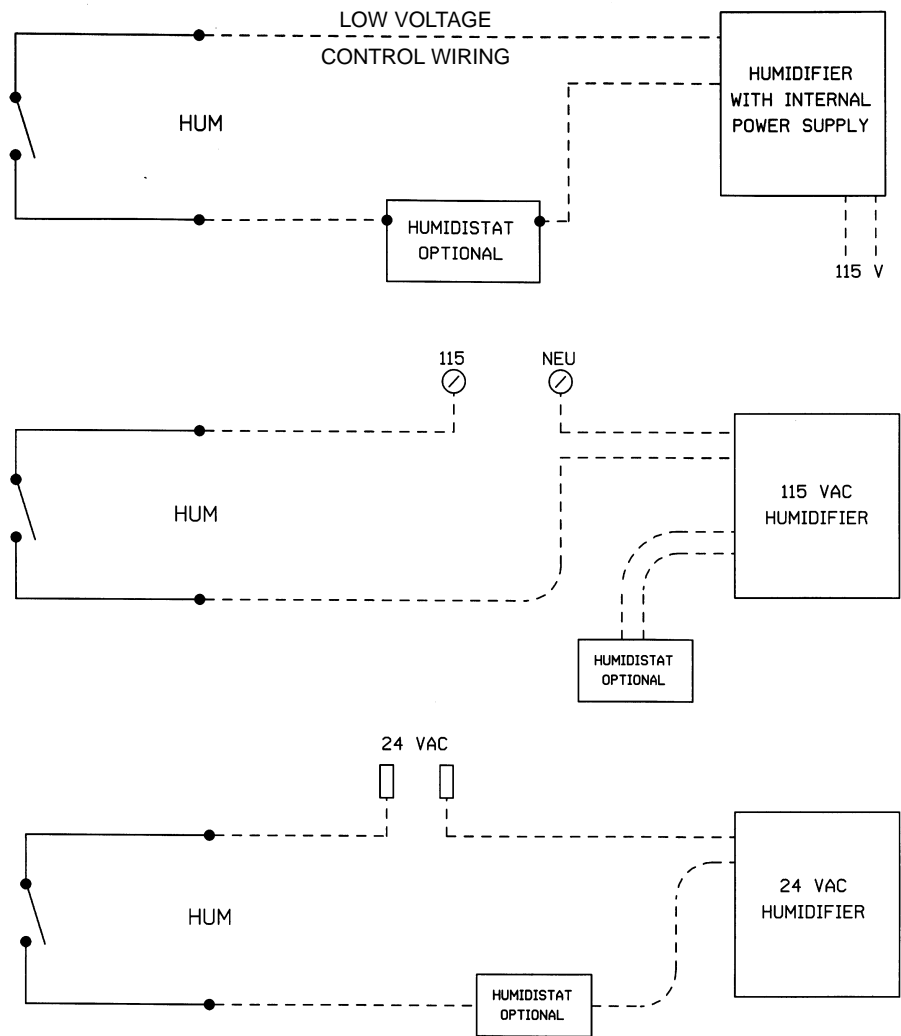
#### HUMIDIFIER

The humidifier contacts (labeled HUMIDIFIER on the IFC) are "dry" contacts on the IFC. This means that the terminals are connected directly to the contacts of a board-mounted relay. The coil of the relay is controlled by the microprocessor of the IFC. The coil is engaged roughly any time the heat speed blower is engaged so that humidification is active any time the heat blower is running. In addition to this control, on 24 VAC humidifiers or humidifiers controlled by a 24 VAC control circuit, an optional 24 VAC humidistat can be installed (see Figure 46). With the optional humidistat, two separate conditions must be met before humidification of the conditioned space can begin: 1) There must be a heat call and the heat speed blower must be running and 2) The humidistat must determine that there is a need for humidification.

**FIGURE 45**  
EAC TERMINAL



**FIGURE 46**  
WIRING FOR OPTIONAL HUMIDIFIER



1681

## DEHUMIDIFICATION IN COOLING OPERATION

Dehumidification in the cooling mode can be accomplished by two different methods. Both methods will reduce the amount of airflow in cooling by 15%. This reduced airflow will cause more water to condense on the evaporator coil thus reducing the humidity in the conditioned space.

**IMPORTANT:** The manufacturer requires that all cooling systems installed with either dehumidification feature enabled **MUST** have a coil of the type with an expansion valve. RCBA coils can be used with the feature(s) enabled provided that there is an expansion valve kit installed with the coil. In addition to these requirements, RCGA, RCBA and RCHA coils must have a freeze-stat (part #RXX-AM01) installed to prevent possible coil freeze-up. Note that the RCBA coils must have **BOTH** an expansion valve kit and a freeze-stat installed.

### Method A: THERMOSTAT DEMAND DE-HUMIDIFICATION

This method for dehumidification relies on an algorithm in the modulating thermostat (part #41-24312-04) to calculate a need for dehumidification based on the number and frequency of cooling calls over a specified period of time. The feature is enabled on the thermostat interface panel. Please read and follow the instructions for the modulating thermostat to enable this feature.

Please note that the thermostat can only estimate when there is a need for dehumidification by looking at the recent history of cooling calls. This is not a true measurement of humidity. For true humidity measurement, a humidistat must be installed per the instructions in method B below.

### Method B: ON-DEMAND DE-HUMIDIFICATION-REFERENCE FIGURES 40A THRU C

On UTECH IFC Revision -03 (62-24174-01 rev 03) or newer (After May 12, 2004) or all revisions of 62-24174-02, an additional method for dehumidification was added to the function of the IFC. This method is not available on units constructed before this date.

The following methods for dehumidification utilize the most accurate means for sensing humidity. A humidistat should be installed to the control board "YL" or "DEHUM" and "R" terminals.

### ON DEMAND DEHUMIDIFICATION ON UTECH IFC #62-24174-01

#### REVISION 03 (62-24174-01 Rev -03)

A humidistat should be installed to the control board "YL" and "R" terminals. PLEASE NOTE THAT TWO-STAGE COOLING AND ON-DEMAND DEHUMIDIFICATION CANNOT BE USED AT THE SAME TIME (IFC REV. 03 ONLY). The dip switch position #6 of bank SW-1 is used to select between either two-stage cooling or on-demand de-humidification, both features can not be used at the same time because

there is only one input used for both. Also, if neither feature is to be used, it does not matter if the dip switch is in the "ON" or "OFF" position. Any humidistat can be used provided it is of the type that can handle 24 volts and opens the contacts when there is a need for de-humidification.

For proper installation of On-Demand De-Humidification, ensure the following:

- Install one wire from one humidistat contact terminal to the IFC "YL" terminal and another wire from the remaining humidistat contact terminal to the IFC "R" terminal.
- When installing, be sure to use a humidistat and NOT a de-humidistat.
- Position dip switch #6 of bank SW-1 to the "ON" position.
- It is not possible to use two-stage cooling and de-humidification feature at the same time.

**NOTE:** When the dip switch position #6 of bank SW-1 is in the on position, a 24 volt signal from the humidistat must be supplied at all times to keep the blower running at the correct cooling speed. When the 24 VAC signal is absent, the IFC assumes there is a need for dehumidification and operates the blower at the reduced rate. This is what is known as "reverse-logic". In other words, when a 24 VAC signal is present, normal operation occurs (100% cooling CFM), however, when there is no signal present, the IFC goes into the dehumidification mode and reduces the airflow by 15%. This could be confusing and will cause the cooling speed to be reduced by 15% if the dip-switch is in the "on" position but no humidistat is connected.

### ON DEMAND DEHUMIDIFICATION IFC #62-24174-02

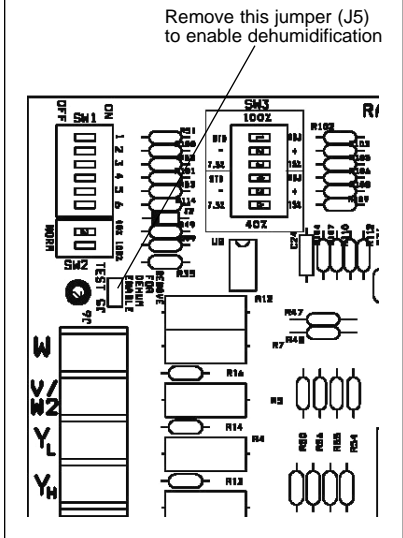
For IFC Revision #62-24174-02 (AVAILABLE 2ND QUARTER 2005) or later, a new dehumidification terminal has been added to the thermostat terminal block. This terminal will permit the user to install dehumidification without the need to manipulate any dip-switches. However, to activate the ODD feature, a jumper located at position J5 (between the thermostat terminal block and dip switch bank SW-2 on the IFC - see Figure 47) must be removed and discarded. This jumper applies 24 volts to the "dehum" terminal at all times in order to prevent the control from reverting to the lower (dehumidification) speed when no voltage is applied.

**IMPORTANT:** Do not remove the jumper at J5 unless a humidistat is installed to the "DEHUM" terminal of the IFC. In addition, the control allows the use of two-stage cooling and dehumidification at the same time and separate cooling airflows for high efficiency (up to 16 SEER) cooling. (see section labeled "FURNACE INSTALLATION WITH HIGH EFFICIENCY PREMIUM COOLING SYSTEMS").

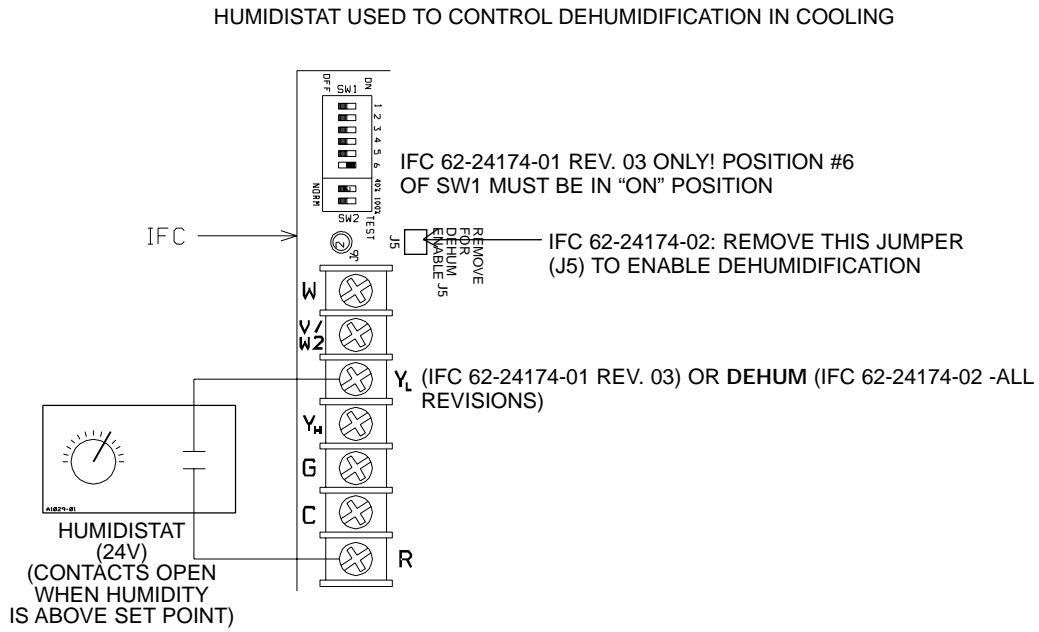
For proper installation of On-Demand De-Humidification, ensure the following:

- Install one wire from one humidistat contact terminal to the IFC "DEHUM" terminal and another wire from the remaining humidistat contact terminal to the IFC "R" terminal.
- When installing, be sure to use a humidistat and NOT a de-humidistat.
- The jumper at position J5 on the control (see Figure 47) has been removed.

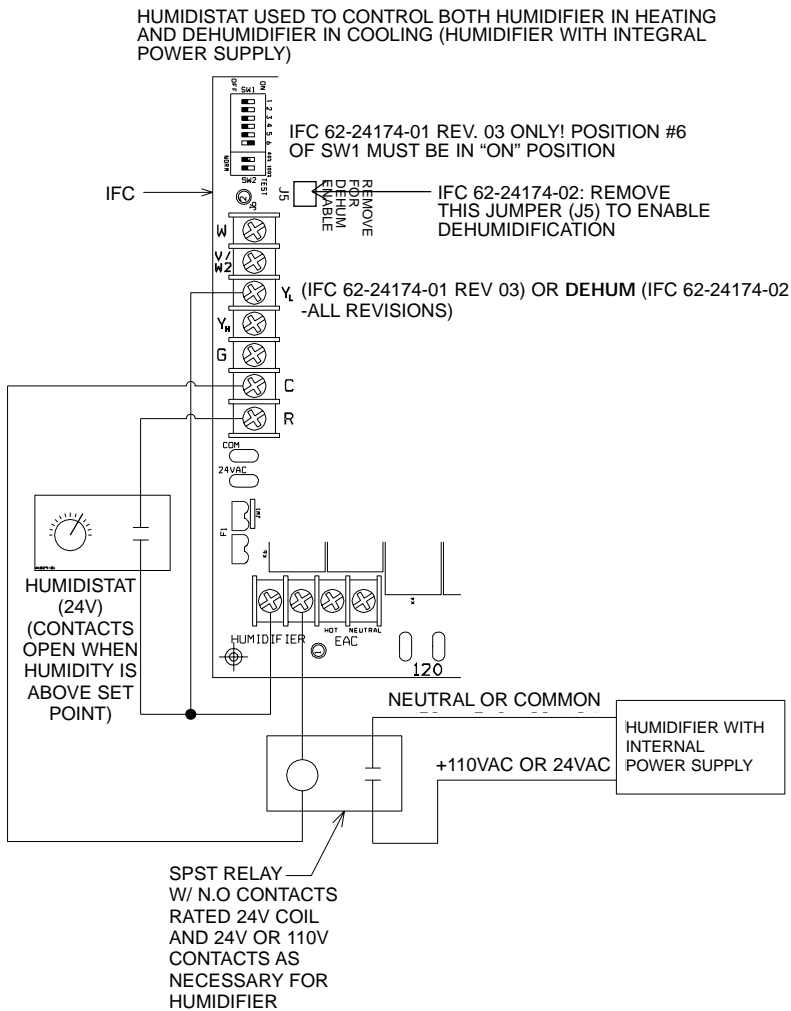
**FIGURE 47**  
UT Electronic Controls IFC. 62-24174-02  
Shown with Nec. Jumper location shown  
to activate dehumidification.



**FIGURE 48**  
WIRING FOR OPTIONAL DEHUMIDIFIER

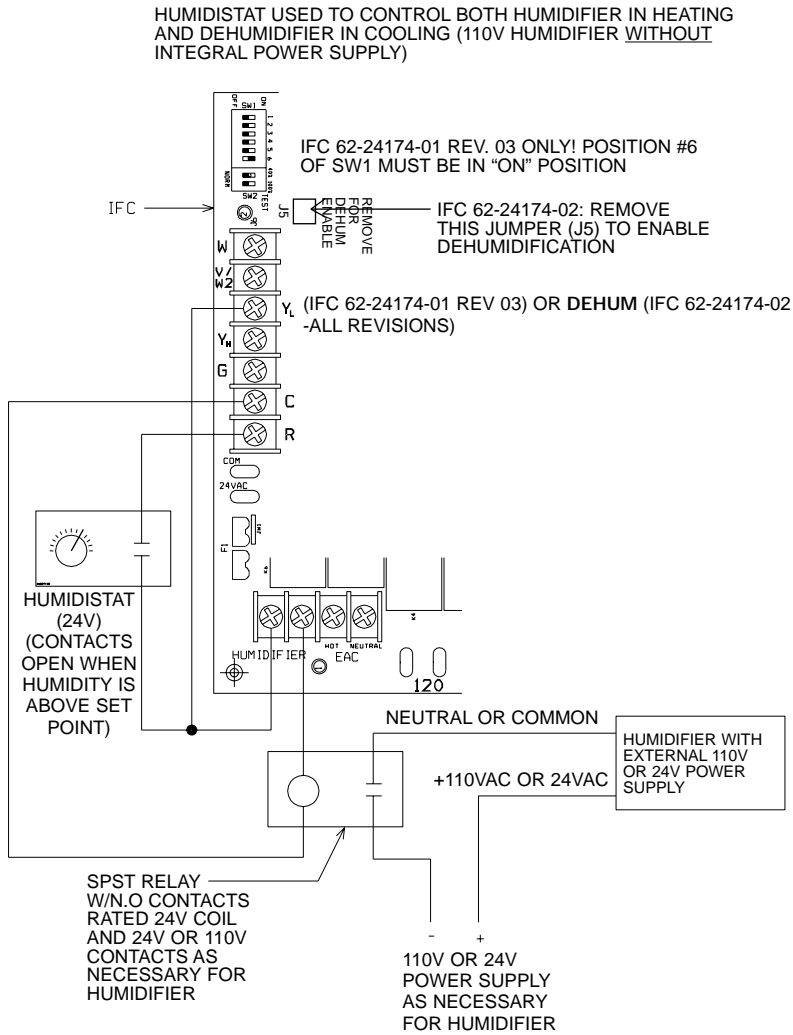


**FIGURE 49**  
WIRING FOR OPTIONAL DEHUMIDIFIER WITH HUMIDIFIER





**FIGURE 50**  
**WIRING FOR OPTIONAL DEHUMIDIFICATION WITH HUMIDIFIER AND SEPARATE POWER SUPPLY.**



### RXPFF-F02 SYSTEM INSTALLATION WITH HEAT PUMPS (REFER TO WIRING DIAGRAMS OF FIGS 51 THRU 53)

As of May 12, 2004, the modulating furnace systems can be installed with heat pump systems provided that the IFC is part number 62-24174-01 REV -03 or greater or 62-24174-02 and that an RXPFF-F02 fossil fuel kit is used to install the system.

Refer to Figures 51 thru 53 for various installation wiring diagrams covering different defrost controls, refrigerant types and optional heat-pump monitor installations. For further instructions, refer to the instructions delivered with the fossil fuel kit.

#### System Operation with Modulating Gas Furnace with RXPFF-F02

**NOTE:** Modulating control must be part number 62-24174-01 Rev. -03 or newer or 62-24174-02.

**NOTE:** Both dip switches of SW-2 of the modulating control (IFC) must be in the "ON" position (timed two-stage heat operation).

**NOTE:** Thermostat must have a "W2" connection for second-stage heat when configured for a modulating furnace.

(continued on next page)

**A. First-Stage Heat Call (Thermostat "Y" + "B")**

- (1) The system receives a demand for heat from the indoor thermostat ("Y" and "B")  
"B" is energized when the indoor thermostat is set to "HEAT"  
"Y" is energized when the indoor thermostat calls for heat.
- (2) "B" is routed directly to the outdoor unit for the heat pump heating control system. (Usually a reversing valve).
- (3) "Y" is routed to the outdoor thermostat:  
Condition 1: When the outdoor air temperature is *above* the setpoint of the outdoor thermostat *and* the indoor thermostat only senses a need for first-stage heat, the operation is normal heat pump. Both the cooling contactor on the condenser and cooling speed fan on the control board (IFC) (via "Y") are energized at this point.  
Condition 2: When the outdoor air temperature is *below* the setpoint of the outdoor thermostat *and* the indoor thermostat only senses a need for first-stage heat, heating control is switched directly to the modulating gas furnace by energizing "W" on the modulating control (IFC) alone. This will give 40% (low fire) gas heat until either a second-stage heat call is present or the thermostat heat call is satisfied. At this point, the thermostat has energized both "Y" and "B", but the fossil fuel kit changes the "Y" signal into a "W" call to the modulating control. The cooling contactor is de-energized during this mode and the compressor and condenser fan are turned off.

The reversing valve (via "B") is energized throughout Condition 1 or 2, but is ignored and has no consequence in Condition 2 since the compressor and condensing fan are not running in Condition 2.

**B. Second-Stage Heat Call (Thermostat "W2" + "Y" + "B")**

- (1) When the system thermostat determines that the indoor air temperature is significantly below the setpoint of the thermostat, it will call for second-stage heat. Second-Stage heat with a modulating furnace as installed and wired per this document will be gas heat starting at 65% of full fire.  
"W2", "Y" and "B" are simultaneously energized by the thermostat.  
"W2" is routed to the modulating furnace control to energize both "W" and "V/W2" on the modulating control board (IFC) (through the relay provided with the RXPF-F02). This turns on gas heat at 65% for seven minutes followed by 100% gas heat until the Second-Stage heat call is satisfied.

"Y" is turned off by the FFK IWB (Fossil Fuel Kit Interface Wiring Board) so that the cooling contactor is NOT energized. **NOTE:** At this point, "Y" from the thermostat to the FFK IWB will be energized, however, neither "Y" between the FFK IWB and the cooling contactor nor "Y" between the FFK IWB and the modulating control (IFC) will be energized.

The reversing valve (via "B") is energized during the Second-Stage heat call, but is ignored and has no consequence on the system since the compressor and condensing fan will not be running during Second-Stage Heat.

**C. Defrost (Thermostat "Y" + "B") (Defrost Control "W2" or "D")**

- (1) The system receives a backup heat demand from the outdoor unit defrost control (Defrost Control "W2" or "D")
- (2) When the defrost control determines there is a need to defrost the coil, the heating call is re-routed by the defrost control back to the FFK IWB. The Defrost control also forces the reversing valve to run the AC system in cooling.
- (3) The Defrost mode heat call from the outdoor unit is routed to the FFK IWB, through the Plenum Sensor and finally to "W" and "V/W2" on the modulating control (IFC). The modulating furnace begins heating at 65% of full fire for seven minutes followed by 100% until the heat/defrost call is satisfied.
- (4) A plenum switch is provided to control heat in the defrost mode. This switch prevents the evaporator coil from overheating when gas heat is running in the defrost mode.
- (5) The "Y" (Cooling) circuit remains energized on the modulating control (IFC). This means that the furnace is running at either 65% or 100% of full fire heat with cooling speed blower.
- (6) The compressor and condensing fan of the cooling system will be running in the cooling direction during the Defrost mode to transfer heat to the condensing coil to melt away any frost or ice build-up on the condenser.

The reversing valve (via B) is de-energized during the defrost cycle. During defrost mode, "B" from the thermostat through the FFK IWB and out to the defrost control will be energized, but the circuit from the defrost control to the reversing valve will NOT be energized as the defrost control forces the reversing valve into cooling.

**D. Call for Emergency Heat (Thermostat "E")**

- (1) In the Emergency Heat mode, the indoor thermostat routes all heat demands (first- and sec-

ond-stage) to the modulating furnace so that, with an Emergency heat call from the thermostat, gas heat will turn on at 65% of full fire for seven minutes followed by 100% until the Emergency Heat call is satisfied.

The reversing valve (via "B") is energized during the Emergency Heat call, but is ignored and has no consequence on the system since the compressor and condensing fan will not be running during Emergency Heat.

**E. Call for Cooling (Thermostat "O", "Y" & "G" or "Y" & "G")**

- (1) In the cooling mode, the system receives a demand for cooling from the indoor thermostat.  
When the thermostat recognizes a need for cooling, "Y" is energized by the thermostat and the FFK IWB uses this signal to energize "Y" to the modulating control (IFC) and to the cooling contactor. In cooling, "B" is de-energized and "O" is energized. This sets the reversing valve for the cooling mode.
- (2) "O" is routed to the outdoor unit for the heat pump cooling control system (usually the "Low-Ambient" relay or alternate reversing valve control system.)

**F. Call for Continuous Fan (Thermostat "G")**

- (1) The system receives a demand from the indoor thermostat "G".
- (2) The fan call is routed directly to the "G" terminal on the modulating control (IFC).

**OTHER ACCESSORIES AVAILABLE**

These kits are available through the finished goods department.

**CONCENTRIC VENT TERMINATION KIT = RXGY-E03**

**HORIZONTAL, TWO-PIPE TERMINATION KIT = RXGY-D02, RXGY-D03, OR RXGY-D04**

**CONDENSATE PUMP KIT: RXGY-B01**

**NEUTRALIZER KIT: RXGY-A01**

**EXTERNAL BOTTOM FILTER RACK: RXGF-CB**

**EXTERNAL SIDE FILTER RACK: RXGF-CA**

These parts are available through ProStock parts department.

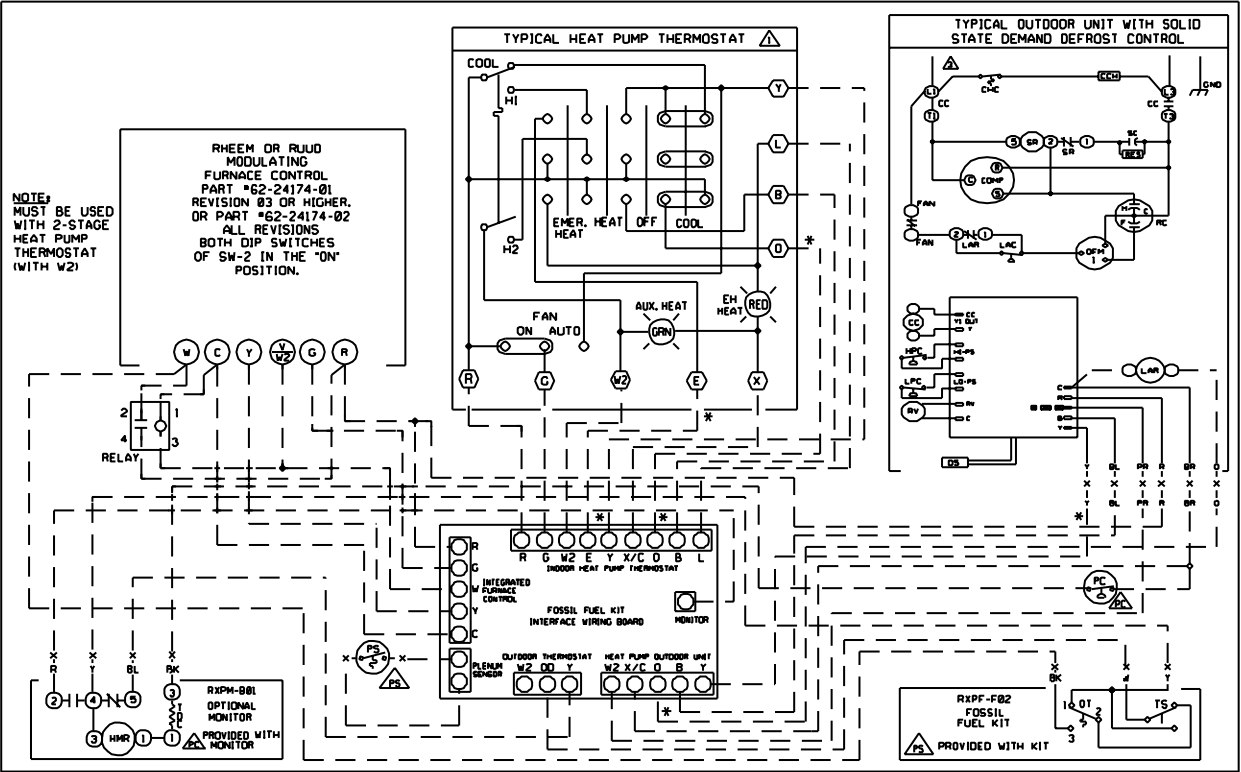
**PROGRAMMABLE MODULATING THERMOSTAT: 41-24312-04**

**NON-PROGRAMMABLE MODULATING THERMOSTAT: 41-25347-01**

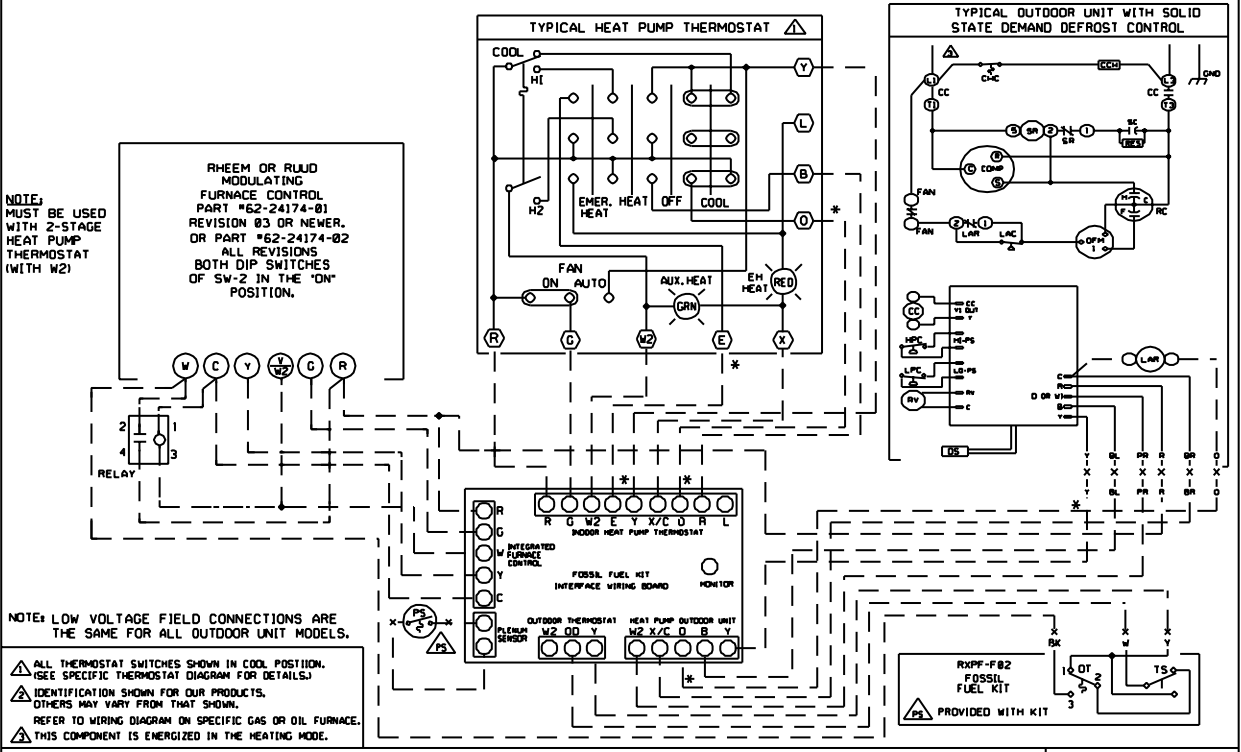
**FIGURE 51**

RXPF-F02 WITH DEMAND-BASED DEFROST CONTROL, SINGLE-PHASE CONDENSOR, R410A REFRIGERANT WITH RHEEM/RUUD MODULATING GAS FURNACE (TVA COMPLIANT)

RXPF-F02 W/ OPTIONAL 2nd STAGE HEAT, SINGLE PHASE CONDENSOR, INTEGRATED DEMAND DEFROST CONTROL, R410A REFRIGERANT, AND RHEEM OR RUUD MODULATING 1-GPD OF -GOD GAS FURNACE WITH OPTIONAL HEAT PUMP MONITOR (RXPM-B01)



RXPF-F02 W/ OPTIONAL 2nd STAGE HEAT, SINGLE PHASE CONDENSOR, INTEGRATED DEMAND DEFROST CONTROL, R410A REFRIGERANT, AND RHEEM OR RUUD MODULATING 1-GPD OF -GOD GAS FURNACE.



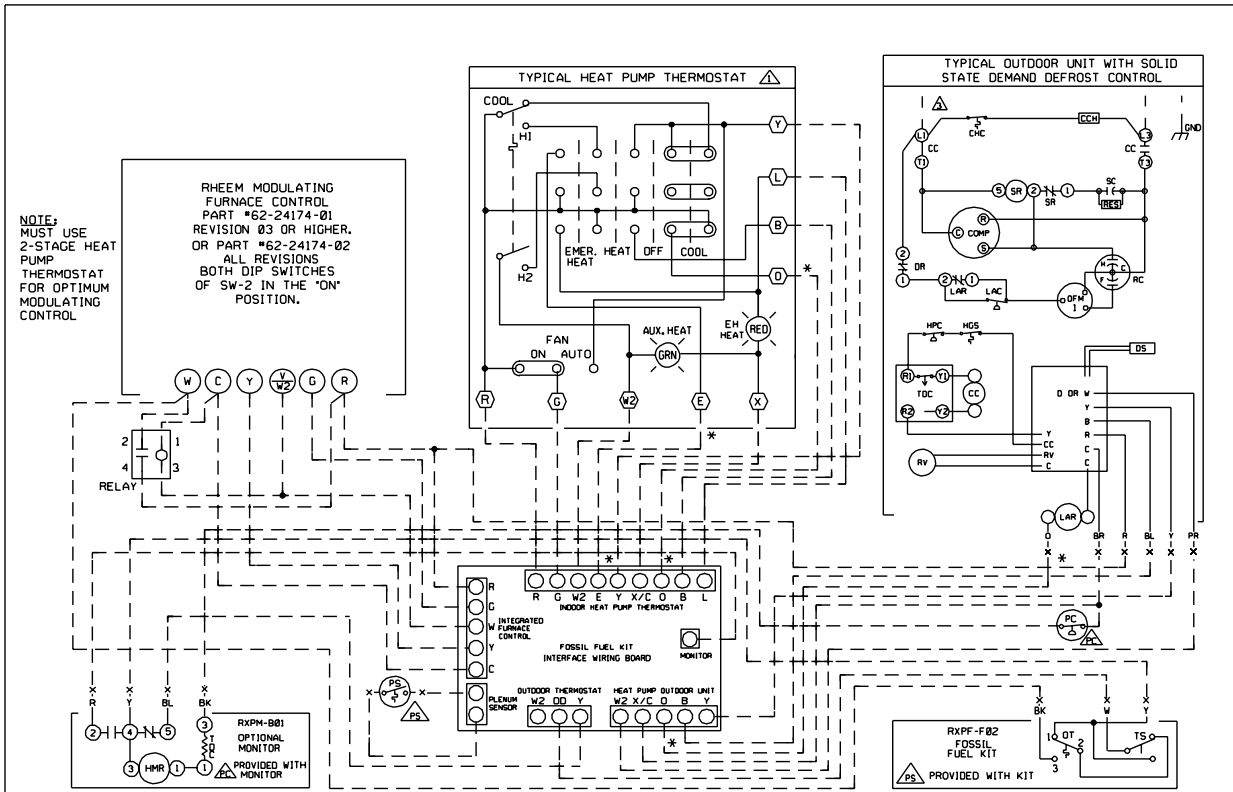
BR	BLOWER RELAY	DR	DEFROST RELAY	LAC	LOW AMB. COOLING CONTROL (OPT)	SC	START CAPACITOR (OPT)
CC	COMPRESSOR CONTACTOR	DS	DEFROST COIL SENSOR	LAR	LOW AMBIENT RELAY (OPT)	SR	START RELAY (OPT)
CH	CRANKCASE HEATER (OPT)	FU	FUSE	OFM	OUTDOOR FAN MOTOR	TDC	TIME DELAY CONTROL (OPT)
CHC	CRANKCASE HEATER CONTROL (OPT)	GV	GAS VALVE	OT	OUTDOOR THERMOSTAT (OPT)	TS	TOGGLE SWITCH
COMP	COMPRESSOR	HGS	HOT GAS SENSOR (OPT)	PC	PRESSURE CONTROL (OPT)	X	OPTIONAL - EMERGENCY HEAT MAY NOT BE CONNECTED IN TVA JURISDICTION.
CT	CONTROL TRANSFORMER	HMR	HEAT MONITOR RELAY (OPT)	PS	PLENUM SENSOR	*	
DAS	DEFROST AMBIENT SENSOR	HPC	HIGH PRESSURE CONTROL	RV	REVERSING VALVE		
DFC	DEFROST CONTROL	IBM	INDOOR BLOWER MOTOR				

WIRE CODE			
FACTORY WIRING	---		
FIELD WIRING	---		
WIRE COLOR CODE			
BK	BLACK	PR	PURPLE
BL	BLUE	R	RED
BR	BROWN	W	WHITE
G	GREEN	Y	YELLOW
O	ORANGE		

90-26255-04-02

**FIGURE 52**  
**RXPFF-F02 WITH DEMAND-BASED DEFROST CONTROL, SINGLE-PHASE CONDENSOR, R22 REFRIGERANT WITH RHEEM/RUUD MODULATING GAS FURNACE (TVA COMPLIANT)**

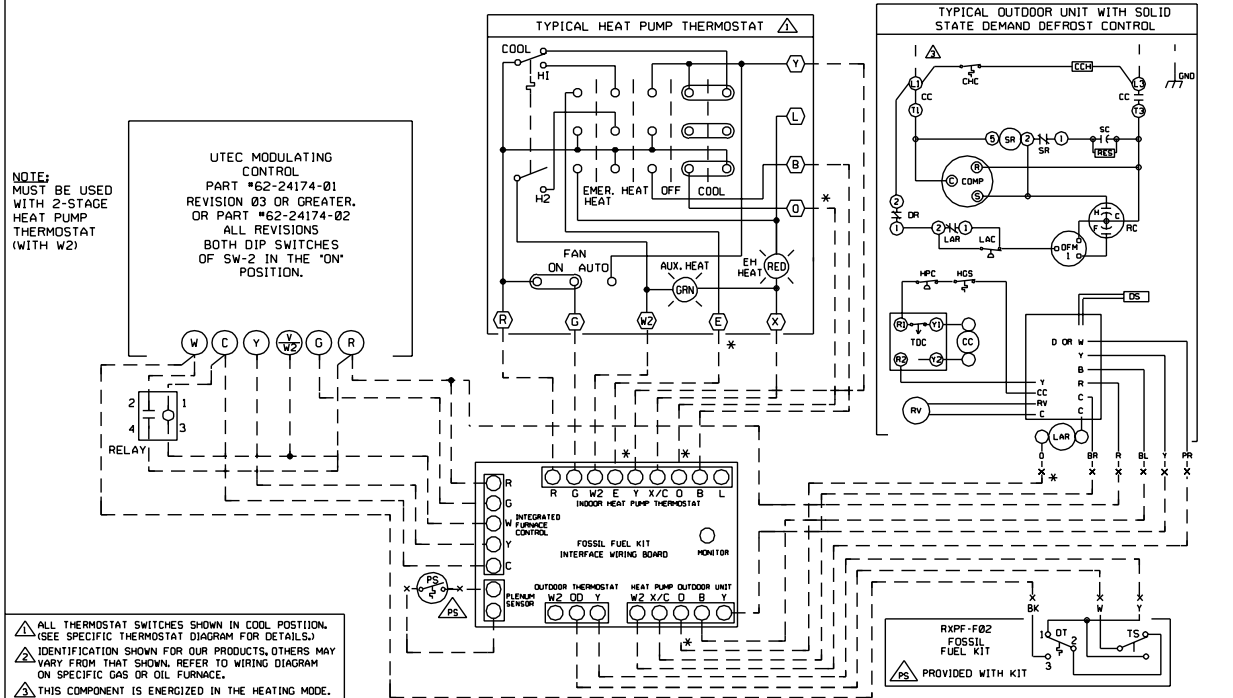
RXPFF-F02 W/ OPTIONAL 2nd STAGE HEAT PUMP, SINGLE PHASE CONDENSOR, INTEGRATE DEMAND DEFROST CONTROL, R22 REFRIGERANT, AND RHEEM OR RUUD MODULATING (GFD, OR -GGDI) GAS FURNACE WITH OPTIONAL MONITOR (RXPFF-B01), TVA COMPLIANT.



**NOTE:**  
 MUST USE  
 2-STAGE HEAT  
 PUMP  
 THERMOSTAT  
 FOR OPTIMUM  
 MODULATING  
 CONTROL

RHEEM MODULATING  
 FURNACE CONTROL  
 PART #62-24174-01  
 REVISION 03 OR HIGHER,  
 OR PART #62-24174-02  
 ALL REVISIONS  
 BOTH DIP SWITCHES  
 OF SW-2 IN THE "ON"  
 POSITION.

RXPFF-F02 W/ OPTIONAL 2nd STAGE HEAT PUMP, SINGLE PHASE CONDENSOR, INTEGRATE DEMAND DEFROST CONTROL, R22 REFRIGERANT, AND RHEEM OR RUUD MODULATING (GFD, OR -GGDI) GAS FURNACE, TVA COMPLIANT.



**NOTE:**  
 MUST BE USED  
 WITH 2-STAGE  
 HEAT PUMP  
 THERMOSTAT  
 (WITH W2)

UTEC MODULATING  
 CONTROL  
 PART #62-24174-01  
 REVISION 03 OR GREATER,  
 OR PART #62-24174-02  
 ALL REVISIONS  
 BOTH DIP SWITCHES  
 OF SW-2 IN THE "ON"  
 POSITION.

- ⚠ ALL THERMOSTAT SWITCHES SHOWN IN COOL POSITION. (SEE SPECIFIC THERMOSTAT DIAGRAM FOR DETAILS.)
- ⚠ IDENTIFICATION SHOWN FOR OUR PRODUCTS, OTHERS MAY VARY FROM THAT SHOWN, REFER TO WIRING DIAGRAM ON SPECIFIC GAS OR OIL FURNACE.
- ⚠ THIS COMPONENT IS ENERGIZED IN THE HEATING MODE.

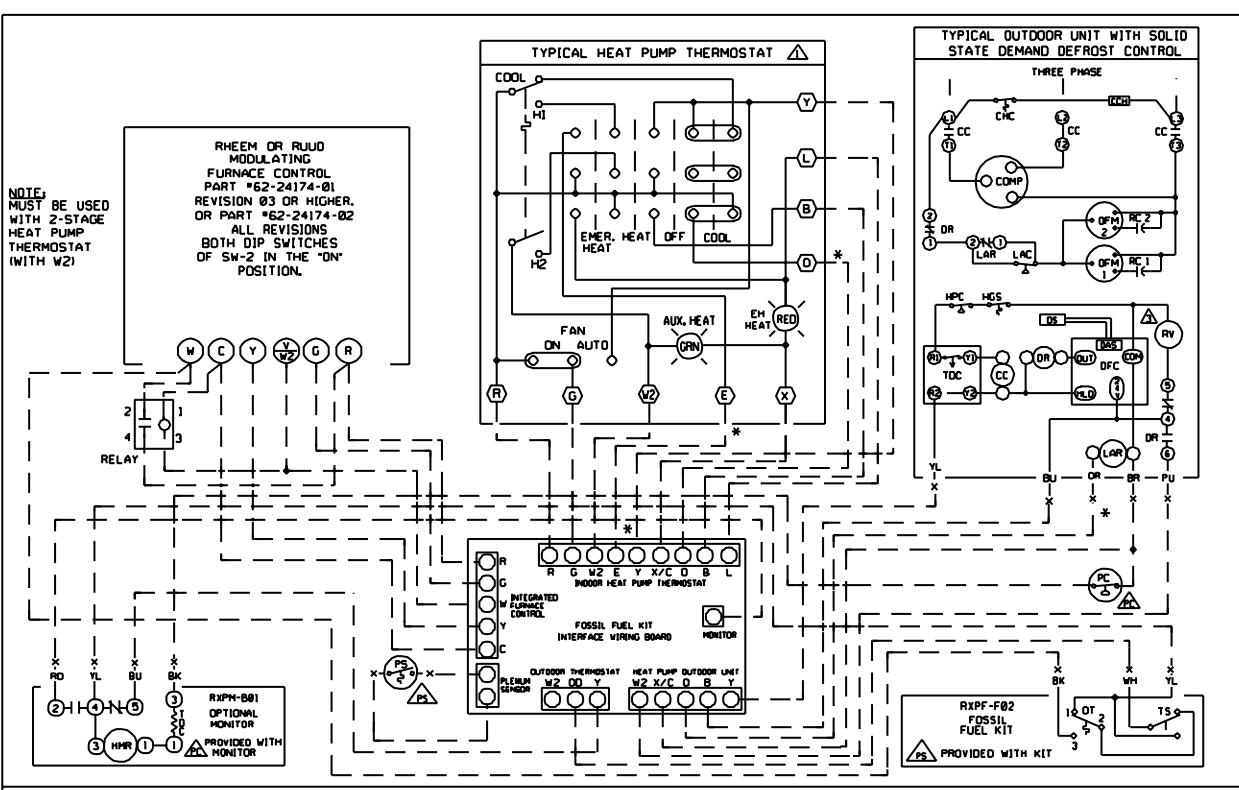
BR	BLOWER RELAY	DR	DEFROST RELAY	LAC	LOW AMB. COOLING CONTROL (OPT)	RV	REVERSING VALVE
CC	COMPRESSOR CONTACTOR	DS	DEFROST COIL SENSOR	LAR	LOW AMBIENT RELAY (OPT)	SC	START CAPACITOR (OPT)
CCH	CRANKCASE HEATER (OPT)	FU	FUSE	OPM	OUTDOOR FAN MOTOR	SR	START RELAY (OPT)
CHC	CRANKCASE HEATER CONTROL (OPT)	GV	GAS VALVE	OT	OUTDOOR THERMOSTAT (OPT)	TDC	TIME DELAY CONTROL (OPT)
COMP	COMPRESSOR	HGS	HOT GAS SENSOR (OPT)	PC	PRESSURE CONTROL (OPT)	TS	TOGGLE SWITCH
CT	CONTROL TRANSFORMER	HMR	HEAT MONITOR RELAY (OPT)	PS	PLENUM SENSOR	X	WIRE NUT
DAS	DEFROST AMBIENT SENSOR	HPC	HIGH PRESSURE CONTROL	RC	RUN CAPACITOR	*	OPTIONAL - NOTE: EMERGENCY HEAT CAN NOT BE CONNECTED IN TVA JURISDICTION
DFC	DEFROST CONTROL	IBM	INDOOR BLOWER MOTOR				

WIRE CODE			
FACTORY WIRING	=====		
FIELD WIRING	-----		
WIRE COLOR CODE			
BK	BLACK	PU	PURPLE
BL	BLUE	RD	RED
BR	BROWN	WH	WHITE
GR	GREEN	YL	YELLOW
OR	ORANGE		

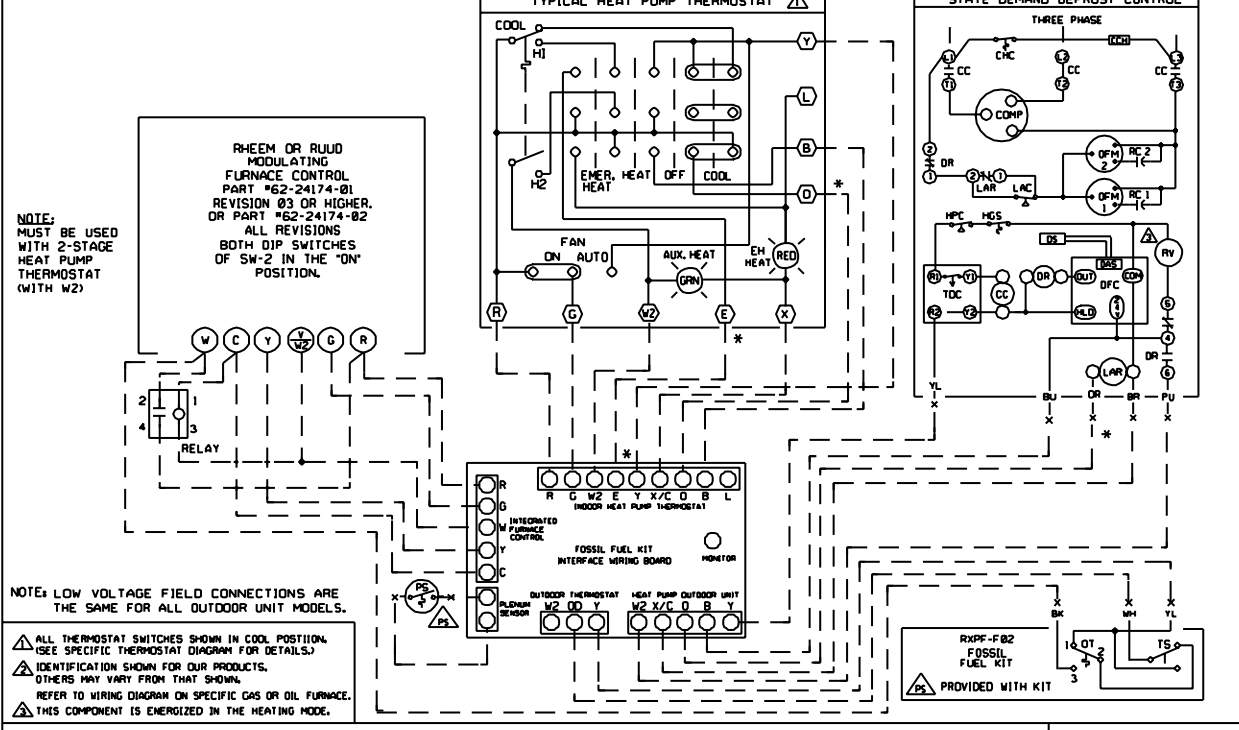
**FIGURE 53**

**RXPF-F02 WITH DEMAND-BASED DEFROST CONTROL, THREE PHASE CONDENSOR, R22 REFRIGERANT WITH RHEEM/RUUD MODULATING GAS FURNACE (TVA COMPLIANT)**

RXPF-F02 w/ OPTIONAL 2nd STAGE HEAT, THREE PHASE CONDENSOR, INTEGRATED DEMAND DEFROST CONTROL w/ R22 REFRIGERANT, AND RHEEM OR RUUD MODULATING (GPD OF -GGD) GAS FURNACE - (TVA COMPLIANT), WITH OPTIONAL HEAT PUMP MONITOR (GPPM-B01)



RXPF-F02 w/ OPTIONAL 2nd STAGE HEAT, THREE PHASE CONDENSOR, INTEGRATED DEMAND DEFROST CONTROL, R22 REFRIGERANT, AND RHEEM OR RUUD MODULATING (GPD OF -GGD) GAS FURNACE (WITHOUT HEAT PUMP MONITOR)



BR	BLOWER RELAY	DR	DEFROST RELAY	LAC	LOW AMB. COOLING CONTROL (OPT)	RV	REVERSING VALVE	WIRE CODE
CC	COMPRESSOR CONTACTOR	DS	DEFROST COIL SENSOR	LAR	LOW AMBIENT RELAY (OPT)	SC	START CAPACITOR (OPT)	FACTORY WIRING
CCM	CRANKCASE HEATER (OPT)	FU	FUSE	OFW	OUTDOOR FAN MOTOR	SR	START RELAY (OPT)	FIELD WIRING
CCH	CRANKCASE HEATER CONTROL (OPT)	GV	GAS VALVE	OT	OUTDOOR THERMOSTAT (OPT)	SD	TIME DELAY CONTROL (OPT)	WIRE COLOR CODE
COMP	COMPRESSOR	HGS	HOT GAS SENSOR (OPT)	PC	PRESSURE CONTROL (OPT)	TS	TOGGLE SWITCH	BK BLACK PU PURPLE
CT	CONTROL TRANSFORMER	HMR	HEAT MONITOR RELAY (OPT)	PS	PRESSURE SENSOR	X	WIRE NUT	BU BLUE RD RED
DAS	DEFROST AMBIENT SENSOR	HPC	HIGH PRESSURE CONTROL	RS	RUN CAPACITOR	*	OPTIONAL - NOTE: EMERGENCY HEAT CAN NOT BE CONNECTED IN TVA JURISDICTION	BR BROWN WH WHITE
DFC	DEFROST CONTROL	IBM	INDOOR BLOWER MOTOR					GR GREEN YL YELLOW
								OR ORANGE

# HIGH ALTITUDE INSTALLATIONS

## -GFD/-GGD -HIGH ALTITUDE OPTION #278

### ▲ WARNING

FOR -GGD-06 MODELS, A PRESSURE SWITCH CHANGE IS NOT NECESSARY AT ANY ELEVATION. FOR -GGD-07 MODELS, A PRESSURE SWITCH CHANGE IS REQUIRED AT ELEVATIONS ABOVE 8,000 FT. FOR ALL OTHER -GFD/-GGD FURNACES, A PRESSURE SWITCH CHANGE IS REQUIRED AT ELEVATIONS ABOVE 5,000 FT. OPTION CODE -278 OR THE APPROPRIATE HIGH-ELEVATION KIT WILL CONVERT THE FURNACE FOR USE ABOVE THE APPROPRIATE ELEVATION STATED HERE. DO NOT INSTALL THE -278 OPTION FURNACE OR THE HIGH ALTITUDE KIT BELOW THE STATED ELEVATION. DOING SO CAN CAUSE SERIOUS PERSONAL INJURY OR DEATH OR EQUIPMENT FAILURE.

Furnaces can be ordered from the factory already converted for high altitude elevations. The factory option for high altitude elevations would be ordered as a 278 option (example: a 105k BTU upflow furnace which is factory converted for high altitude elevations would have the model number -GFD-10EZCMS278). These factory converted furnaces come with pressure switches for high-altitude elevations already attached. Also, different burner orifices are installed at the factory which are one drill size smaller (#51 DMS) than standard -GFD/GGD gas furnaces (#50 DMS). The smaller orifice is installed to accommodate for average heating values expected in most high altitude areas and a required 4% per thousand feet reduction in input as specified by the *National Fuel Gas Code* (NFGC). Specific orifices should always be recalculated for all high altitude installations as outlined below. Orifices should be changed, if necessary, based on gas heating value and elevation.

## HIGH ALTITUDE CONVERSION KITS AND OPTIONS

### ▲ WARNING

FOR -GGD-06 MODELS, A PRESSURE SWITCH CHANGE IS NOT NECESSARY AT ANY ELEVATION. FOR -GGD-07 MODELS, A PRESSURE SWITCH CHANGE IS REQUIRED AT ELEVATIONS ABOVE 8,000 FT. FOR ALL OTHER -GFD/-GGD FURNACES, A PRESSURE SWITCH CHANGE IS REQUIRED AT ELEVATIONS ABOVE 5,000 FT. OPTION CODE -278 OR THE APPROPRIATE HIGH-ELEVATION KIT WILL CONVERT THE FURNACE FOR

USE ABOVE THE APPROPRIATE ELEVATION STATED HERE. DO NOT INSTALL THE -278 OPTION FURNACE OR THE HIGH ALTITUDE KIT BELOW THE STATED ELEVATION. DOING SO CAN CAUSE SERIOUS PERSONAL INJURY OR DEATH OR EQUIPMENT FAILURE.

### HIGH ALTITUDE FIELD CONVERSION KITS (GFD MODELS)

MODEL	INPUT(BTU)	KIT NO.
-GFD-06XXXXX	60,000	RXGY-F06
-GFD-07XXXXX	75,000	RXGY-F07
-GFD-09XXXXX	90,000	RXGY-F06
-GFD-10XXXXX	105,000	RXGY-F05
-GFD-12XXXXX	120,000	RXGY-F05

### HIGH ALTITUDE FIELD CONVERSION KITS (GGD MODELS)

MODEL	INPUT(BTU)	KIT NO.
-GGD-06XXXXX	60,000	No Kit Required
-GGD-07XXXXX	75,000	RXGY-F23 (8000 ft and above only)
-GGD-09XXXXX	90,000	RXGY-F24
-GGD-10XXXXX	105,000	RXGY-F25
-GGD-12XXXXX	120,000	RXGY-F26

### Orifice Selection for High Altitude Applications Natural Gas

### ▲ CAUTION

DO NOT ATTEMPT TO ADJUST MANIFOLD GAS PRESSURE FOR ELEVATION ON (-)GGD OR (-)GFD FURNACE MODELS. THIS METHOD IS NOT PERMITTED ON THESE MODELS!

**Caution.** The National Fuel Gas Code (NFGC) guidelines should be followed when converting these furnaces for high altitude operation.

34" 90 Plus furnaces (except for opt -278 models) installed at high elevations require the installation of a high altitude kit for proper operation. The high altitude kit consists of a high altitude pressure switch that replaces the pressure switch attached to the induced draft blower.

The pressure switch must be installed at elevations above those listed. Elevations above 2000 ft. require the furnace to be de-rated 4% per thousand feet. **NOTE:** Factory installed ori-

fices are calculated and sized based on a sea level Natural Gas heating value of 1075 BTU per cubic ft. Regional reduced heating values may nullify the need to change orifices except at extreme altitudes. Table 10 shows some quick conversions based on elevation and gas heating value. This table is combined and simplified from Tables F1 and F4 of the NFGC.

The following are examples of orifice sizing using the National Fuel Gas Code Appendix F. For a simplified estimation of orifice size based on heating value and elevation use Tables 10 and 11. However, calculations are the best method.

### Example: 900 BTU/ft<sup>3</sup> Regional Natural Gas Heating Value

$$I / H = Q$$

$$15000 / 900 = 16.68 \text{ ft}^3/\text{hr}$$

I = Sea Level input (per burner): 15000

H = Sea Level Heating Value: 900  
Q = 16.68 ft<sup>3</sup> Natural Gas per hour.

From Table F.1 of *National Fuel Gas Code Handbook, 2002* (3.5" w.c. column)

Orifice required at Sea Level: # 48

From Table F.4 of *National Fuel Gas Code Handbook, 2002*

Orifice required at 5000 ft. elevation (4% de-rate per thousand ft): # 50  
Orifice required at 8000 ft. elevation (4% de-rate per thousand ft): # 51

### Example: 1050 BTU/ft<sup>3</sup> Regional Natural Gas Heating Value

$$I / H = Q$$

$$15000 / 1050 = 14.63 \text{ ft}^3/\text{hr}$$

I = Sea Level input (per burner): 15000

H = Sea Level Heating Value: 1050  
Q = 14.28 ft<sup>3</sup> Natural Gas.

From Table F.1 of *National Fuel Gas Code Handbook, 2002* (3.5" w.c. column)

Orifice required at Sea Level: # 50

From Table F.4 of *National Fuel Gas Code Handbook, 2002*

Orifice required at 5000 ft. elevation (4% de-rate per thousand ft): # 51  
Orifice required at 8000 ft. elevation (4% de-rate per thousand ft): # 52

**TABLE 10**

Natural Gas Orifice Drill Size (4% per 1000 ft. De-Rate)

**IMPORTANT:** For 90+ Furnaces only. Do not use this chart for any 80+ Furnace.

Burner Input (per burner) 25,000 BTU @ Sea Level

Annual Avg. Heat Value (btu per ft <sup>3</sup> )	Sea level to 1999 ft	2000 to 2999 ft	3000 to 3999 ft	4000 to 4999 ft	5000 to 5999 ft	6000 to 6999 ft	7000 to 7999 ft	8000 to 8999 ft
850	47	48	48	49	49	49	50	50
900	48	49	49	49	50	50	50	51
1000	49	50	50	50	51	51	51	52
1075	50	51	51	51	51	52	52	52
1170	51	51	52	52	52	53	53	53

**TABLE 11**

**90 Plus ONLY models with 15,000 Btu's per Burner. DO NOT USE THIS CHART FOR ANY 80 PLUS MODEL.**

**NATURAL GAS QUICK REFERENCE CHART FOR ORIFICE SELECTION, AT 3.5" W.C. AND APPROXIMATE FINAL FIRING RATES**

Sea Level Orifice Size	Sea Level Cubic Foot at 3.5" W.C.	90 Plus Heat Value at 15,000 Btu's per Burner	ELEVATION CHART (NFG recommended orifice based on 4% derate for each 1000 foot of elevation, based on the intersection of the orifice required at Sea Level and the elevation required below)												
			0-999	1000-1999	2000-2999	3000-3999	4000-4999	5000-5999	6000-6999	7000-7999	8000-8999	9000-9999			
46	18.57	808	46	46	47	47	47	47	48	48	48	49	49	49	50
47	17.52	856	47	47	48	48	48	49	49	49	49	50	50	50	51
48	16.36	917	48	48	49	49	49	49	50	50	50	51	51	51	51
49	15.2	987	49	49	50	50	50	50	51	51	51	51	51	52	52
50	13.92	1078	50	50	51	51	51	51	51	51	52	52	52	52	53
51	12.77	1175	51	51	51	52	52	52	52	52	52	53	53	53	53
Final Firing Rate per Burner			15,000	14,400	13,800	13,200	12,600	12,000	11,400	10,800	10,200	9,600			

**All calculations are performed by using the first three columns of information only. Before beginning any calculations, determine the individual burner Btu size and heating value at Sea Level for the installation site. Each value shown in the Heat Value column is per burner at 3.5" W.C.**

**NOTE:**

Heat Value at Sea Level, for the location of the installation, is available from the Natural Gas Supplier to that site. Orifices for all altitudes are based on Sea Level values.

Divide the individual burner capacity (15,000 for 90 plus) by the Heat Value for the site to determine the Cubic Foot value at Sea Level, or divide burner capacity by the Cubic Foot value for the Heat Value. Once you have either the Cubic Foot Value or the Heat Value you can estimate the Sea Level orifice for the site. To select the corresponding high altitude orifice, locate the site elevation on the chart above and the orifice required at Sea Level from your calculation in the first column. The correct high altitude orifice that must be installed in each individual burner is the intersection of these two points on the chart above.

## LP GAS AT HIGH ALTITUDE ELEVATIONS

LP Gas is a manufactured gas that has consistent heating value across most regions.

The NFGC guidelines are used with the following exception:

The recommended LP Gas high altitude orifice selections differ slightly in that the NFGC LP orifice chart, as they are not accurate for the (-)GFD or (-)GGD gas furnace. The National Fuel Gas Code LP orifices are based on an 11" of water column pressure at the orifice, which differs from products that use 10" of water column at the orifice. This difference requires a deviation from the NFGC orifice size recommendations. The Sea Level input should still be reduced by 4% per thousand ft. and the orifice size must be selected based on the reduced input selection shown in Table 12.

### Orifice Ordering Information

Orifice sizes are selected by adding the 2-digit drill size required in the orifice part number. Drill sizes available are 39 through 64; metric sizes available 1.10mm (-90) and 1.15mm (-91):

Orifice Part Number 62-22175-(drill size)

Example 1:  
#60 drill size orifice required  
Part #62-22175-60

Example 2:  
1.15mm drill size orifice required  
Part #62-22175-91

**TABLE 12**

LP Gas Orifice Drill Size and per burner de-rate by elevation based on 15,000 btu 90+ burners.

**IMPORTANT:** For 90+ Furnaces only. Do not use this chart for any 80+ Furnace.

Altitude	Input (per burner) 15000	Orifice Size
0 to 2000 ft.	15000	1.15 mm (factory)
2001' to 3000'	13200	1.15 mm
3001' to 4000'	12600	1.10 mm
4001' to 5000'	12000	#58
5001' to 6000'	11400	#59
6001' to 7000'	1080	#60
7001' to 8000'	10200	#62
8001' to 9000'	9600	#63
9001' to 10000'	9000	#64



## ZONING SYSTEMS

The manufacturer does not currently provide or support zoning with modulating furnace. However, zoning systems can be installed with the system as long as the zoning equipment manufacturers specifications and installation instructions are met and followed.

The preferred zoning method is to use a “bypass” system which is properly installed for maximum efficiency. In these systems, excess air is routed back through the system to be used again – this is opposed to a “dump” system in which excess air is routed to a zone where it is expected that the extra heat or cooling would be least noticed.

If installed as a “bypass” system, the installation must have an optional freeze stat installed to prevent the coil from icing with excess bypass cooling. Also, if the zoning equipment manufacturer provides a limit switch (usually provided by the zoning manufacturer), this limit must be installed in the system to prevent the furnace from overheating.

## FURNACE INSTALLATION WITH HIGH-EFFICIENCY PREMIUM COOLING SYSTEMS

Furnace installation with Rheem/Ruud -ARA or -ARL outdoor condensing units can provide high efficiency (up to 16 SEER) cooling operation when combined with proper evaporator coil. For listed cooling equipment combinations, see the -ARA or -ARL specification sheets. Using Tables 13 and 14 and literature provided with the cooling equipment, the installer needs to make sure that the proper evaporator coil, condensing coil and airflow is configured to achieve rated efficiency.

### UP TO 16 SEER COOLING OPERATION

Check the revision number of the integrated furnace control (IFC) to determine how best to configure your furnace for high SEER operation.

#### IFC #62-24174-02

To achieve high SEER operation, turn dip switch #6 of bank SW1 to the “on” position. This will enable the furnace operation for 16 SEER. Actual SEER values will vary and depend on the equipment combination. Consult the specifications sheets and installation instructions of the cooling equipment purchased for a listing of the SEER ratings for a specific combination.

## ALL OTHER INTEGRATED FURNACE CONTROLS

High SEER operation with IFC's other than 62-24174-02 may not achieve rated performance or desired comfort levels. For these older models, there are no additional adjustments necessary to the furnace. For optimum performance, replace with IFC #62-24174-02.

### A NOTE ABOUT DEHUMIDIFICATION:

High SEER systems may require the use of the onboard dehumidification feature of this system. Be sure to consult the section titled “ON DEMAND DEHUMIDIFICATION” on page 42 of this document.

## HORIZONTAL CONVERSION KITS RXGY-G02, RXGY-G03, RXGY-G04 & RXGY-G05

Horizontal installation of the (-)GGD modulating gas furnace is permitted with the use of special kits available from the manufacturer. The gas valve must be mounted upright. This is accomplished with a special manifold supplied with the conversion kit. Assembly requires the removal of the existing gas manifold and replacing it with the one supplied in the kit.

**TABLE 13**  
AIRFLOW AND CONDENSER SELECTION – PREMIUM COOLING SYSTEMS (1 STAGE COOL ONLY)

TONS	FURNACE		APPROX. AIRFLOW (CFM)	CONDENSING UNIT	MOD. FURNACE IFC DIP-SWITCH SETTINGS			
	MODEL	WIDTH			SW-1,#1	SW-1,#2	SW-1,#3	SW-1,#4
2	-GFD/GGD-06 & -07	17.5"	800	-ARA-24	OFF	ON	OFF	OFF
2-1/2	-GFD/GGD-06 & -07*	17.5"	1000	-ARA-30	ON	OFF	OFF	OFF
3	-GFD/GGD-09 & -10*	21"	1200	-ARA-36	ON	ON	OFF	OFF
3-1/2	-GFD/GGD-09 & -10*	21"	1400	-ARA-42	ON	ON	OFF	OFF
3	-GFD/GGD-12	24.5"	1200	-ARA-36	ON	ON	OFF	OFF
3-1/2	-GFD/GGD-12	24.5"	1400	-ARA-42	ON	ON	OFF	OFF

Evaporator coil must be the same width as the furnace OR one size larger in width than the gas furnace.  
(See condenser spec. sheet, I&O and other literature for evaporator selection)

**TABLE 14**  
AIRFLOW AND CONDENSER SELECTION – PREMIUM COOLING SYSTEMS (2 STAGE COOL ONLY)

TONS	FURNACE		APPROX. AIRFLOW (CFM)	CONDENSING UNIT	MOD. FURNACE IFC DIP-SWITCH SETTINGS			
	MODEL	WIDTH			SW-1,#1	SW-1,#2	SW-1,#3	SW-1,#4
2	-GFD/-GGD-06 & -07	17.5"	800	-ARL-24	OFF	ON	OFF	OFF
3	-GFD/-GGD-06 & -07	17.5"	1200	-ARL-36	OFF	OFF	OFF	OFF
3	-GFD/-GGD-09 & -10	21"	1200	-ARL-36	ON	ON	OFF	OFF
3	-GFD/-GGD-12	24.5"	1200	-ARL-36	ON	ON	OFF	OFF
4	-GFD/-GGD-09 & -10	21"	1600	-ARL-48	ON	OFF	OFF	OFF
4	-GFD/-GGD-12	24.5"	1600	-ARL-48	ON	OFF	OFF	OFF
5	-GFD/-GGD-12	24.5"	1800	-ARL-60	OFF	OFF	OFF	OFF

Evaporator coil must be the same width as the furnace OR one size larger in width than the gas furnace.  
(See condenser spec. sheet, I&O and other literature for evaporator selection)

# INTEGRATED FURNACE CONTROL

## GENERAL

The UT Electronic Controls IFC board (see Figure 41) is a recent addition to the furnace and will be a direct replacement for all Johnson Controls IFC boards. New features have been added to the IFC board to improve airflow performance in the heating mode. The new board also adds two-stage capability in addition to the existing modulating and single-stage operation. Also, the locations of the original dip switches (SW1 & SW2), and the location of the seven segment display are different than the previous Johnson Controls IFC board. The function of these components has not changed.

► **IMPORTANT:** The dip switches on SW2 (used for test mode and for operation with two-stage thermostats) must be in the "OFF" position for modulating or single-stage operation. If both switches are in the "ON" position, a missing "V" signal with a call on "W" will cause the furnace to run only at 40%. However, with both switches in the "ON" position, the furnace will function with a two-stage thermostat when connected as shown in Figure 44.

## DIP SWITCH SET SW1

For proper setting of the airflow switches to meet requirements, see Figures 55 and 56.

**IMPORTANT:** Do not attempt to install a (-)GFD or (-)GGD modulating furnace with a conventional, add-on zone system. System performance and occupant comfort may be compromised.

## ► DIP SWITCH SET SW2

The UT Electronic Controls IFC board has added two-stage capabilities. This feature is activated by changing the switches 1 & 2 of SW2 to the "ON" position and installing a two-stage thermostat as shown in Figure 44. This feature allows the furnace to be used with a standard two-stage thermostat. With switches 1 & 2 of SW2 set to the "ON" position, the furnace will go to 40% of capacity when "W" is energized alone. In this configuration, when "W" and "W2"

**TABLE 15**  
SW2 MODE SELECTION SETTINGS

Mode	Switch 1 Position	Switch 2 Position
Modulating/Single-Stage	OFF	OFF
Test 40%	ON	OFF
Test 100%	OFF	ON
Two-Stage	ON	ON

are energized, the furnace runs at 65% for five minutes and then changes to 100%. If the call for heat ends at any time the furnace terminates immediately at the present firing rate.

## DIP SWITCH SET SW3

The UT Electronic Controls IFC board has an added set of dip switches labeled SW3 (see Figure 53). The function of these dip switches is to fine-tune airflow in the heating mode. The dip switches will be set to either the 40% or 100% (or both) firing rate, and will adjust every point in between accordingly.

SW3 will allow for airflow adjustments at high altitude, improper temperature probe locations, or no temperature probe applications. If temperature rise range is a problem, the technician must use temperature probes to determine the rise range and adjust the airflow using SW3's dip switches until the temperature rise is within the specified range.

## ADJUSTING AIRFLOW

All airflow adjustments on SW3 should be made with the main power OFF. Dip switches 1 through 3 will adjust airflow at the 100% firing rate and dip switches 4 through 6 will adjust the airflow at the 40% firing rate.

### 100% Firing Rate

To use SW3 to change the airflow at the 100% rate:

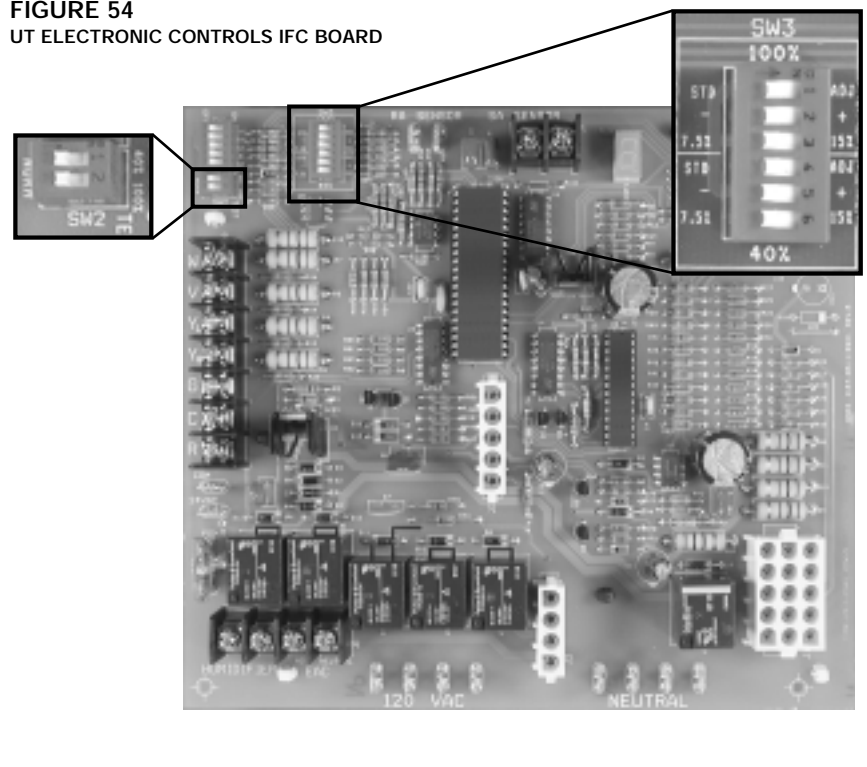
- 1) Dip switch 1 must be "ON" (or "ADJ"). This instructs the IFC that the high firing rate airflow will be overridden.
- 2) Dip switch 2 in the "OFF" position will decrease airflow at 100% fire, and in the "ON" position will increase airflow at 100% fire.
- 3) If dip switch 3 is "OFF" the amount airflow will be adjusted by 7.5%. If it is "ON" amount of airflow will be adjusted by 15%.

### 40% FIRING RATE

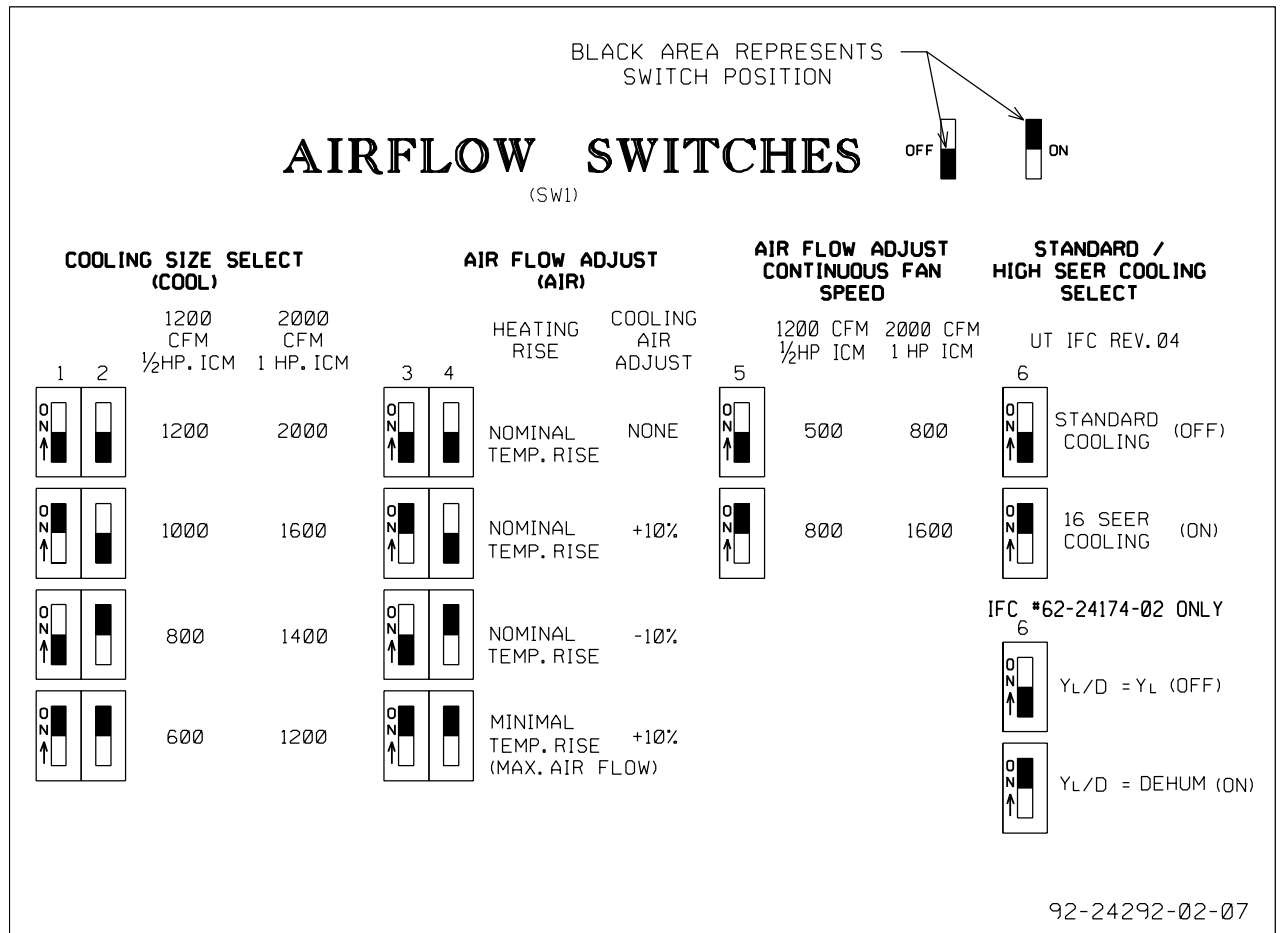
To use SW3 to change the airflow at the 40% rate:

- 1) Dip switch 4 must be "ON" (or "ADJ"). This instructs the IFC that the high firing rate airflow will be overridden.
- 2) Dip switch 5 in the "OFF" position will decrease airflow at 40% fire, and in the "ON" position will increase airflow at 40% fire.
- 3) If dip switch 6 is "OFF" the amount airflow will be adjusted by 7.5%. If it is "ON" amount of airflow will be adjusted by 15%.

**FIGURE 54**  
UT ELECTRONIC CONTROLS IFC BOARD



**FIGURE 55**  
**AIRFLOW SWITCHES (SW1)**



# AIRFLOW ADJUSTMENT EXAMPLES

Three examples of airflow adjustment are shown below.

**NOTE:** All dip switches on SW3 will be shipped in the "OFF" position.

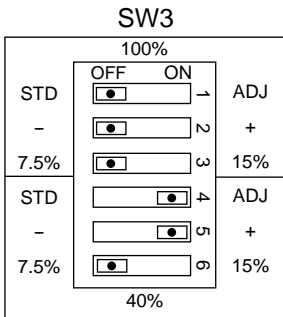
## Example 1 (see Figure 56)

**PROBLEM:** Temperature rise is too high at 40% firing rate although it is within the published range at 100% firing rate.

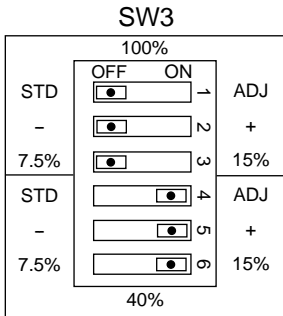
**SOLUTION:** More airflow is needed to lower the temperature rise at 40%.

- 1) Set dip switches 4 and 5 of SW3 to the "ON" position. This will produce a 7.5% increase in blower output.
- 2) Allow furnace to run for several minutes at 40% firing rate until temperature probes reach equilibrium.
- 3) If the temperature rise is still above the published range, set switch 6 of SW3 to the "ON" position. This will increase the airflow rate from +7.5% to +15% above the standard value.

**FIGURE 56**  
EXAMPLE 1



A. Set switches 4 & 5 to "ON" position to increase airflow by 7.5% at the 40% fire rate.



B. If +7.5% is not enough, increase airflow by setting switch 6 to "ON" position to give +15%.

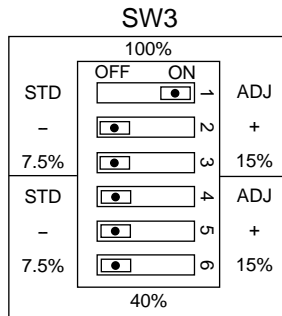
## EXAMPLE 2 (see Figure 57)

**PROBLEM:** Temperature rise is too low at 100% firing rate although it is within the published range at 40% firing rate.

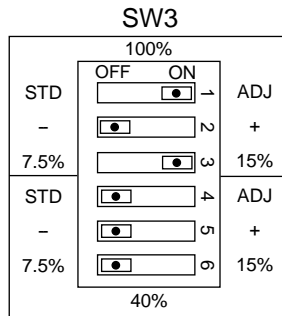
**SOLUTION:** Less airflow is needed to increase temperature rise at 100%.

- 1) Set dip switch 1 of SW3 to the "ON" position, which overrides standard airflow.
- 2) Leave switches 2 and 3 in the "OFF" position to decrease airflow by 7.5%.
- 3) Allow furnace to run for several minutes at 100% rate until temperature probes reach equilibrium.
- 4) If the temperature rise is still below the published range, set switch 3 to the "ON" position. This will decrease the airflow rate from -7.5% to -15% below the standard value.

**FIGURE 57**  
EXAMPLE 2



A. Set switch #1 to "ON" position and leave #2 and #3 in the "OFF" position to decrease airflow by 7.5% at the 100% fire rate.



B. If -7.5% is not enough, decrease airflow by setting switch 3 to "ON" position to give -15%.

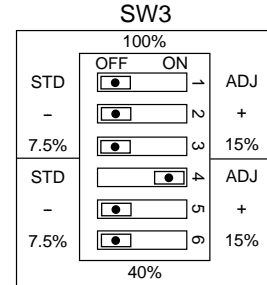
## EXAMPLE 3 (see Figure 58)

**PROBLEM:** Temperature rise is too low at 40% firing rate and is too high at 100%.

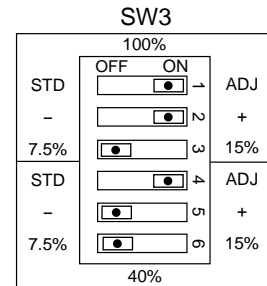
**SOLUTION:** Less airflow is needed to increase temperature rise at 40% firing rate and more is needed to decrease temperature rise at 100%.

- 1) Set dip switch 4 of SW3 to the "ON" position to override standard airflow at 40% firing rate. Leave switches 5 and 6 in "OFF" position to decrease airflow by 7.5%.
- 2) Allow furnace to run for several minutes at 40% rate until temperature probes reach equilibrium.
- 3) If temperature rise is still lower than the published range, set switch 6 to the "ON" position to decrease the airflow rate from -7.5% to -15% below the standard value.
- 4) Set dip switches 1 to the "ON" position to override standard airflow at 100% firing rate. Set switch 2 to the "ON" position to increase airflow by 7.5%.
- 5) Allow furnace to run for several minutes at 100% rate until temperature probes reach equilibrium.
- 6) If temperature rise is still higher than the published range, set switch 3 to "ON" position to increase the airflow rate from 7.5% to 15% above the standard value.

**FIGURE 58**  
EXAMPLE 3



A. Set switch #4 to "ON" and leave #5 and #6 set to "OFF" to decrease airflow by 7.5% at the 40% fire rate. If necessary, set switch #6 to "ON" to decrease airflow by 15%.



B. Set switches #1 and #2 to "ON" and leave #3 set to "OFF" to increase airflow by 7.5% at the 100% fire rate. If necessary, set switch #3 to "ON" to increase airflow by 15%.

# START-UP PROCEDURES

## FURNACE TEST MODE

### FURNACE TEST SWITCHES

**NOTE:** The integrated furnace control does not recognize switch setting changes while energized. To change settings, remove power to the board, make changes, then return power.

The Integrated Furnace Control is equipped with three sets of field selectable switches. The set with five switches (SW1) (See Figures 45 and 46) is for selecting airflow operation options (Airflow Switches). The set with two switches (SW2) is for placing the furnace into test mode for initial set-up and troubleshooting and for choosing between modulating, single-stage and two-stage functions. (see Figure 45).

The Test Switches will place the IFC into a test mode, operating the furnace at continuous input rates of either 100% of full rate (maximum fire) or 40% of full rate (minimum fire and 2-stage operation). This is accomplished by setting the Test Switches as indicated in Table 16.

**TABLE 16**  
SW2 MODE SELECTION SETTINGS

Mode	Switch 1 Position	Switch 2 Position
Modulating/ Single-Stage	OFF	OFF
Test 40%	ON	OFF
Test 100%	OFF	ON
Two-Stage	ON	ON

To enter the Furnace Test Mode, proceed as follows:

1. Switch the 115 volt power to the furnace OFF. **Do not change settings with control energized.**
2. Position Test Switches 1 and 2 for the desired test mode.
3. Switch the 115 volt power to the furnace ON.
4. Set the thermostat mode to HEAT, adjust the setpoint at least 4°F above room temperature to demand a call for heating.

When the furnace is powered with the test switches in a position other than modulating/single-stage or in 2-stage mode, the first call for heat within the first hour after power-up will instruct the furnace to perform as follows:

1. Normal ignition sequence
2. A calibration cycle will be performed unless the Test Switches are set for Test 40%. The LED status indicator will flash "H" or "h" during the calibration cycle (see Table 18).

**NOTE:** The return air sensor (factory installed) and the supply air sensor (field installed) are required for the furnace calibration cycle. If the air sensors are faulty, or not properly connected, the furnace will not attempt a calibration cycle and will operate on factory default parameters pre-programmed into the micro-processor.

3. After calibration, the furnace will then adjust to the desired Test capacity. This allows time for the technician to check steady-state operation and evaluate furnace performance.

**NOTE:** Refer to Figure 54 (Furnace Test Mode Sequence of Operation/Troubleshooting), and Furnace Performance Data Table 17.

4. The furnace will operate at the fixed Test capacity until one of the following conditions:
  - a. The thermostat is satisfied and the call for heat is removed.
  - b. The furnace has been in test mode continuously for sixty minutes, at which time the controller will go into modulating/single-stage operation.

**NOTE:** The IFC will only check the test mode switches on power up. Terminating the test mode by either 4a or 4b will place the furnace into modulating or single-stage operation regardless of the test mode switch positions.

To set the furnace for normal operation:

1. Set the thermostat mode to OFF. Always allow furnace to complete the cool down cycle.
2. Switch the 115 volt power to the furnace OFF. **Do not change settings with control energized.**
3. Position Test Switches 1 and 2 for modulating/single-stage mode or 2-stage mode.
4. Switch the 115 volt power to the furnace ON.
5. Set the thermostat as desired.

## THERMOSTAT TEST MODE

SEE THERMOSTAT SECTION OF THESE INSTRUCTIONS FOR TEST-MODE DIRECTIONS.

## TO START THE FURNACE

1. Remove the burner compartment control access door.
2. **IMPORTANT:** Be sure that the manual gas control has been in the "OFF" position for at least five minutes. Do not attempt to manually light the main burners.
3. Set the room thermostat to its lowest setting and turn off the furnace electrical power.
4. Turn the gas control knob to the "ON" position.
5. Replace the burner compartment control access door.

### **▲ WARNING**

**FAILURE TO REPLACE THE BURNER DOOR CAN CAUSE PRODUCTS OF COMBUSTION TO BE RELEASED INTO THE CONDITIONED AREA RESULTING IN PERSONAL INJURY OR DEATH.**

6. Turn on the furnace electrical power.
7. Set the room thermostat at least 4° F above room temperature to light the main burners.
8. After the burners are lit, set the room thermostat to a desired temperature.

**TABLE 17**  
FURNACE PERFORMANCE DATA

Operating Level	Inducer Speed	Servo Valve Current	Manifold Pressure	Temperature Rise
100%	High	~180 milliamps	Natural - 3.5" w.c. ( $\pm 0.3$ ")	40°-70° F
			LP - 10.0" w.c. ( $\pm 0.5$ ")	
90%	High	~162 milliamps	Natural - 2.8" w.c. ( $\pm 0.3$ ")	40°-70° F
			LP - 8.1" w.c. ( $\pm 0.5$ ")	
80%	High	~144 milliamps	Natural - 2.2" w.c. ( $\pm 0.3$ ")	40°-70°F
			LP - 6.4" w.c. ( $\pm 0.5$ ")	
70%	High	~126 milliamps	Natural - 1.7" w.c. ( $\pm 0.3$ ")	40°-70°F
			LP - 4.9" w.c. ( $\pm 0.5$ ")	
60%	High	~108 milliamps	Natural - 1.3" w.c. ( $\pm 0.3$ ")	40°-70°F
			LP - 3.6" w.c. ( $\pm 0.5$ ")	
50%	High	~90 milliamps	Natural - 0.9" w.c. ( $\pm 0.3$ ")	40°-70°F
			LP - 2.5" w.c. ( $\pm 0.5$ ")	
40%	Low	~72 milliamps	Natural - 0.6" w.c. ( $\pm 0.3$ ")	40°-70°F
			LP - 1.6" w.c. ( $\pm 0.5$ ")	
Calibration	High	~135 milliamps	Natural - 2.0" w.c. ( $\pm 0.3$ ")	40°-70°F
			LP - 5.6" w.c. ( $\pm 0.5$ ")	

**NOTE:** Gas valve milliamp readings may vary  $\pm 05\%$ .

**TABLE 18**  
NORMAL OPERATION INDICATORS - DIAGNOSTIC LED

LED SYMBOL	DESCRIPTION	COMMENTS All symbols indicate furnace control board is properly powered.
O	System OFF	There is no demand from the thermostat. There are no active faults.
F	System FAN ONLY	The IFC is receiving 24V on the "G" terminal ONLY. There are no active faults.
C	System COOL	The IFC is receiving 24 V on the "YL" and/or "YH" terminals. There are no active faults.
H	System HEAT	The IFC is receiving 24 V on the "W" terminal. The modulating signal is present on the "V" terminal. There are no active faults.
h	System HEAT	The IFC is receiving 24 V on the "W" terminal. The modulating signal is NOT present on the "V" terminal. There are no active faults.
"H" Flashing	Calibration Cycle	The IFC is receiving 24 V on the "W" terminal. The modulating signal is present on the "V" terminal. The furnace is in calibration mode. There are no active faults.
"h" Flashing	Calibration Cycle	The IFC is receiving 24 V on the "W" terminal. The modulating signal is NOT present on the "V" terminal. The furnace is in calibration mode. There are no active faults.

## TO SHUT DOWN THE FURNACE

1. Set the room thermostat to its lowest setting.
2. Remove the burner compartment control access door.
3. Shut off the gas to the main burners by turning the gas control knob to the "OFF" position.
4. Replace the burner compartment control access door.

### **▲ WARNING**

**SHOULD OVERHEATING OCCUR OR THE GAS SUPPLY FAIL TO SHUT OFF, CLOSE THE MANUAL GAS VALVE FOR THE APPLIANCE BEFORE SHUTTING OFF THE ELECTRICAL SUPPLY. FAILURE TO DO SO CAN CAUSE AN EXPLOSION OR FIRE RESULTING IN PROPERTY DAMAGE, PERSONAL INJURY OR DEATH.**

## SEQUENCE OF OPERATION

### *Heating Cycle Initiation*

The heating cycle is always initiated by a 24 volt signal on W of the thermostat. When the controller senses 24 volts on W, the following sequence occurs:

- High and low pressure switches are checked to insure contacts are open.
- Inducer is powered on high speed for a thirty (30) second prepurge.
- Pressure switches are monitored as the inducer creates the vacuum to close the contacts.
- The servo valve on the gas valve is energized with ~180 milliamps current. (No flow yet.)
- The controller sends 120 volts to the ignition control, which sparks across the electrodes.
- The main solenoids on the gas valve are energized allowing gas to flow to the burners.
- When flame is proven, the ignition control is de-energized - 8 second maximum trial time.
- The gas valve maintains 100% rate through the warm-up period - 20 seconds.

### *Heating Cycle Response*

The heating cycle is always initiated by a 24 volt signal on W1. When the controller senses 24 volts on W1, the following sequence occurs:

#### **MODULATING FUNCTION:**

("W" and "V" signal inputs, refer to dip switch set SW2 on IFC)

After the warm-up period, the furnace will respond to the thermostat demand by adjusting the gas valve pressure and blower speed anywhere between 40% to 100% heating capacity.

**TABLE 19**  
METER TIME

METER TIME IN MINUTES AND SECONDS FOR NORMAL INPUT RATING OF FURNACES EQUIPPED FOR NATURAL OR LP GAS											
INPUT BTU/HR	METER SIZE CU. FT.	HEATING VALUE OF GAS BTU PER CU. FT.									
		900		1000		1040		1100		2500 (LP)	
		MIN.	SEC.	MIN.	SEC.	MIN.	SEC.	MIN.	SEC.	MIN.	SEC.
60,000	ONE	0	54	1	0	1	3	1	6	2	30
	TEN	9	0	10	0	10	24	11	0	25	0
75,000	ONE	0	44	0	48	0	50	0	53	2	0
	TEN	7	12	8	0	8	19	8	48	20	0
90,000	ONE	0	36	0	40	0	42	0	44	1	40
	TEN	6	0	6	40	7	0	7	20	16	40
105,000	ONE	0	31	0	34	0	36	0	38	1	26
	TEN	5	10	5	40	6	0	6	20	14	20
120,000	ONE	0	27	0	30	0	31	0	33	1	15
	TEN	4	30	5	0	5	10	5	30	12	30

$$\text{Formula: Input BTU/HR} = \frac{\text{DRY Heating Value of Gas (BTU/FT}^3\text{)} \times 3600}{\text{Time in Seconds (for 1 cu. ft.) of Gas}} \times C \cdot F$$

$$\text{Where } C \cdot F = \frac{\text{Gas Pressure (inch} \cdot \text{Hg)} \times 520 \text{ (}^\circ\text{F)}}{\text{Gas Temperature (}^\circ\text{F)} \times 30 \text{ (inches} \cdot \text{Hg)}}$$

#### ► TWO-STAGE FUNCTION:

(Two-stage function only applies when both switches of SW2 are in the "ON" position and a two-stage thermostat is installed as shown in Figure 30.) After the warm-up period, the furnace will respond to the thermostat demand by adjusting the gas valve pressure and blower heating speeds to the "W" signal values. "W" only = 40% gas valve pressure and blower heating speed. "W2" = 65% gas valve pressure and blower heating speed for first five minutes and 100% thereafter. Also, if the call for heat ends, the furnace terminates at the present rate.

#### ► SINGLE-STAGE FUNCTION:

("W" signal only)

After the warm-up period, the furnace will respond to the thermostat demand by altering the gas valve pressure and blower speed as follows:

**Phase 1:** 0 to 5 minutes = 40% of furnace capacity (gas valve output and blower speed)

**Phase 2:** 5 to 12 minutes = 65% of furnace capacity (gas valve output and blower speed)

**Phase 3:** After 12 minutes = 100% of furnace capacity (gas valve output and blower speed)

**NOTE:** If the call for heat ends during any phase, the furnace will terminate immediately at the firing rate of that phase.

### *Heating Cycle Termination*

("W" signal only, refer to dip switch set SW2 on IFC)

When the 24 volt signal is removed from W1, the heating cycle will end and the furnace will shut down and return to the proper off cycle operation.

## SETTING INPUT RATE

Checking furnace input is important to prevent over firing beyond its design-rated input. NEVER SET INPUT ABOVE THAT SHOWN ON THE RATING PLATE. Use the following table or formula to determine input rate. Prior to checking the furnace input, make certain that all other gas appliances are shut off, with the exception of pilot burners. Time the meter with only the furnace in operation. Start the furnace, in Furnace Test Mode, 100% rate, and measure the time required to burn one cubic foot of gas.

The furnace is shipped from the factory with #50 orifices. They are sized for natural gas having a heating value of 1075 BTU/cu. ft. and a specific gravity of .60. For high-altitude models (option 278) the furnace comes equipped with #51 orifices installed for elevations above 5,000 ft. These orifices may still need to be changed based on both elevation and gas heating value. Consult the section of this book titled "High Altitude Installation" for details.

Since heating values vary geographically, the manifold pressure and/or gas orifice size may need to be changed to adjust the furnace to its nameplate input. The rate will also vary with altitude. Consult the local gas utility to obtain the yearly average heating value and orifice size required to fire each individual burner at 15,000 BTUH. For high altitude installations, also consult the section of this manual titled "High Altitude Installations" for details on how to calculate the correct orifice size.

# MAINTENANCE

## ⚠ WARNING

**DISCONNECT MAIN ELECTRICAL POWER TO THE UNIT BEFORE ATTEMPTING ANY MAINTENANCE. FAILURE TO DO SO CAN CAUSE ELECTRICAL SHOCK RESULTING IN PERSONAL INJURY OR DEATH.**

## FILTERS

Keep the filters clean at all times. Remove the filter. Vacuum dirt from filter, wash with detergent and water, air dry thoroughly and reinstall.

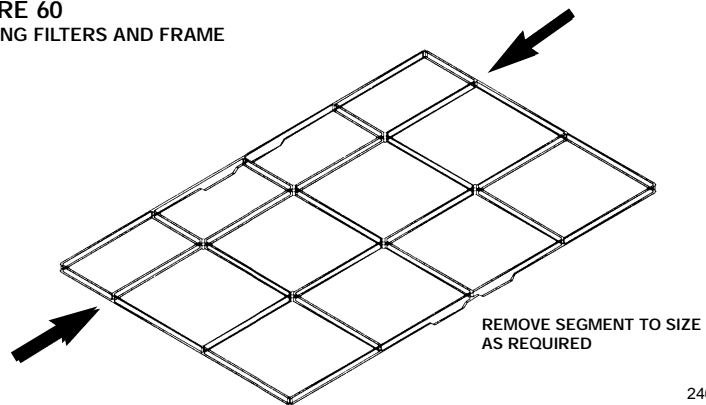
**NOTE:** Some filters must be resized to fit certain units and applications. See Table 14 and Figures 59, 60, 61 and 62.

1. 21" - 90,000 & 105,000 BTUH units require removal of a 3 1/2-in. segment of filter and frame to get the proper width for a side filter.
2. 24 1/2" - 120,000 BTUH unit requires removal of a 7" segment of filter and frame to get the proper width for a side filter.

**TABLE 20  
FILTER SIZES**

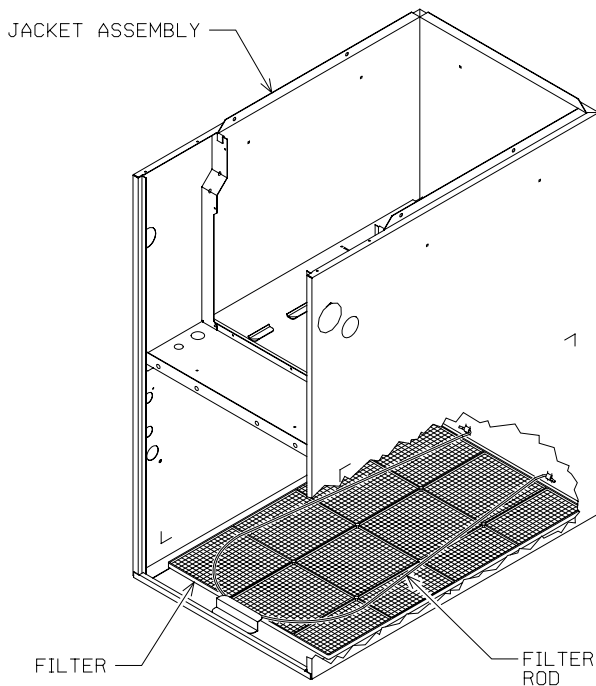
UPFLOW FILTER SIZES				
FURNACE WIDTH	INPUT KBTUH	BOTTOM SIZE	SIDE SIZE	QUANTITY
17 1/2"	60 AND 75	15 3/4" X 25"	15 3/4" X 25"	1
21"	90 AND 105	19 1/4" X 25"	15 3/4" X 25"	1
24 1/2"	120	22 3/4" X 25"	15 3/4" X 25"	1

**FIGURE 60  
RESIZING FILTERS AND FRAME**



2409401

**FIGURE 59  
UPFLOW — FILTER REPLACEMENT**

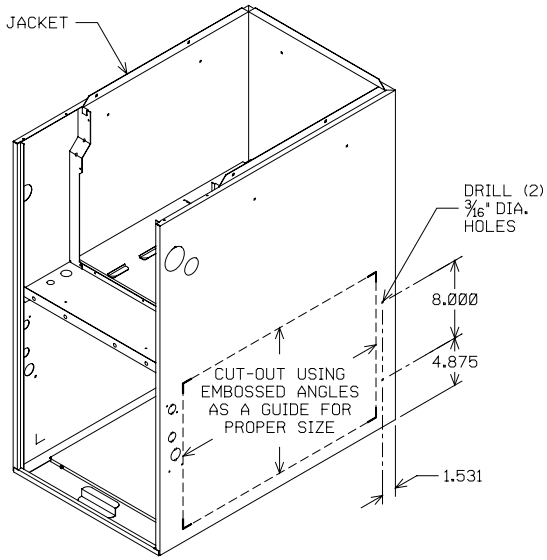


**FILTER & ROD LOCATION**

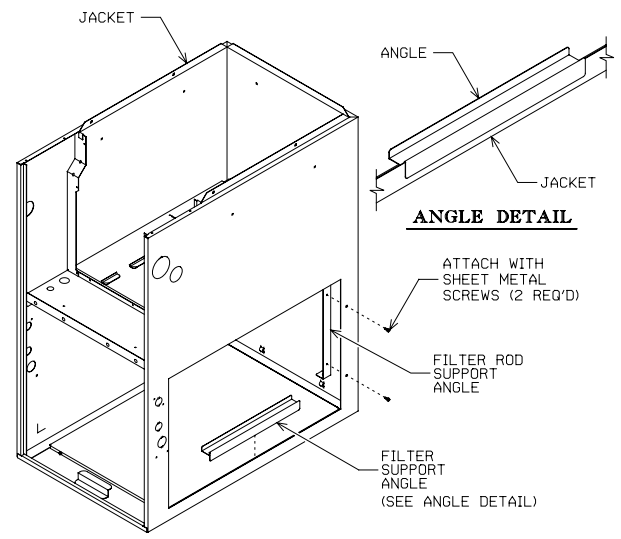
542201



**FIGURE 61**  
UPFLOW -- SIDE FILTER LOCATIONS



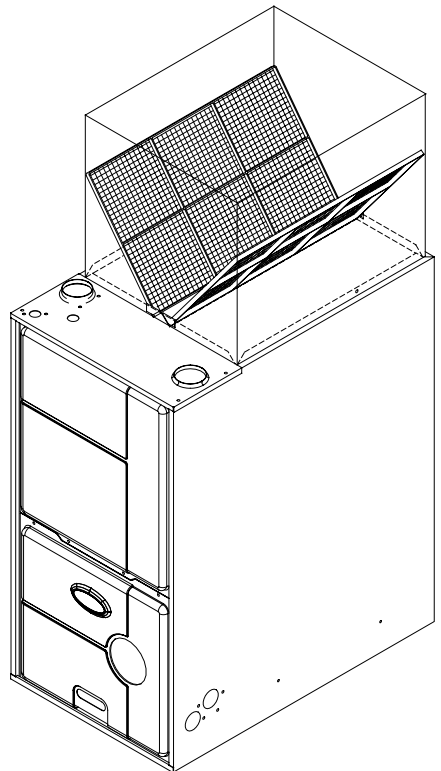
**CUT-OUT AND DRILL DETAIL**



**ROD & FILTER SUPPORT ANGLE ASSEMBLY**

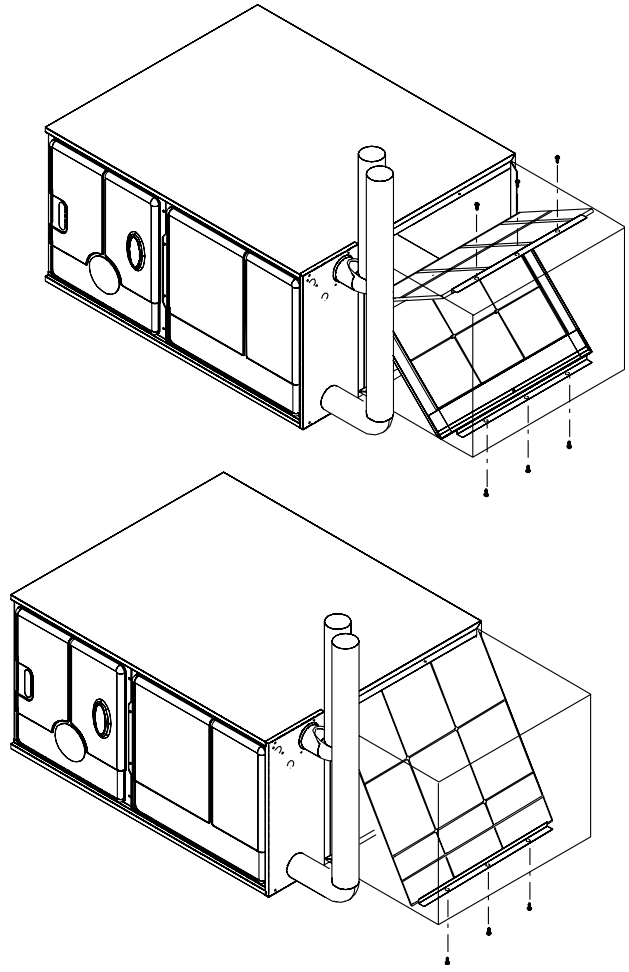
1332

**FIGURE 62**  
DOWNFLOW -- FILTER INSTALLATION



A087001.S01

**FIGURE 63**  
HORIZONTAL -- FILTER INSTALLATION



A087101.S01

## ▲ CAUTION

**DO NOT OPERATE THE SYSTEM FOR EXTENDED PERIODS WITHOUT FILTERS. A PORTION OF THE DUST ENTRAINED IN THE AIR MAY TEMPORARILY LODGE IN THE AIR DUCT RUNS AND AT THE SUPPLY REGISTERS. ANY RECIRCULATED DUST PARTICLES WILL BE HEATED AND CHARRED BY CONTACT WITH THE FURNACE HEAT EXCHANGER. THIS RESIDUE WILL SOIL CEILINGS, WALLS, DRAPES, CARPETS AND OTHER HOUSEHOLD ARTICLES.**

## LUBRICATION

**IMPORTANT:** Do Not attempt to lubricate the bearings on the blower motor or the induced draft blower motor. Addition of lubricants can reduce the motor life and void the warranty.

The blower motor and induced draft blower motor bearings are prelubricated by the manufacturer and do not require further attention.

The blower motor and induced draft blower motor must be cleaned periodically by a qualified installer, service agency, or the gas supplier to prevent the possibility of overheating due to an accumulation of dust and dirt on the windings or on the motor exterior. The air filters should be kept clean. As dirty filters can restrict airflow. The motor depends upon sufficient air flowing across and through it to keep from overheating.

## SYSTEM OPERATION INFORMATION

### Advise The Customer

**IMPORTANT:** Replace all blower doors and compartment covers after servicing the furnace. Do not operate the unit without all panels and doors securely in place.

1. Keep the air filters clean. The heating system will operate more efficiently and more economically.
2. Arrange the furniture and drapes so that the supply air registers and the return air grilles are unobstructed.
3. Close doors and windows. This will reduce the heating load on the system.

4. Avoid excessive use of kitchen exhaust fans.
5. Do not permit the heat generated by television, lamps or radios to influence the thermostat operation.
6. Explain proper operation of the system with constant air circulation.

## ANNUAL INSPECTION

The furnace should operate for many years without excessive scale build-up in the flue passageways. However, it is recommended that a qualified installer, service agency, or the gas supplier annually inspect the flue passageways, the vent system and the main burners for continued safe operation. Pay particular attention to deterioration from corrosion or other sources.

During the annual inspection, all electrical power to the furnace should be turned off and then restored. This will put the furnace into a calibration cycle on the initial call for heat. This is a five minute (or until the heat call is satisfied) cycle which allows the furnace to evaluate conditions. It should be noted, that a calibration cycle will occur on the initial call for heat each time after line voltage has been interrupted to the unit.

**IMPORTANT:** It is recommended that at the beginning and at approximately half way through the heating season, a visual inspection be made of the main burner flames for the desired flame appearance by a qualified installer, service agency or the gas supplier. If the flames are distorted and/or there is evidence of back pressure, check the vent and inlet air system for blockage. If there is carbon and scale in the heat exchanger tubes, the heat exchanger assembly should be replaced.

## ▲ WARNING

**HOLES IN THE VENT PIPE OR HEAT EXCHANGER CAN CAUSE TOXIC FUMES TO ENTER THE HOME, RESULTING IN CARBON MONOXIDE POISONING OR DEATH. THE VENT PIPE OR HEAT EXCHANGER MUST BE REPLACED IF THEY LEAK.**

**IMPORTANT:** It is recommended that at the beginning of the heating season, the flame sensor be cleaned with steel wool by a qualified installer, service agency or the gas supplier.

**IMPORTANT:** It is recommended that at the beginning of the heating season, the condensate trap be inspected for debris or blockage. A blocked condensate trap can cause water to back up into the primary heat exchanger and lead to nuisance tripping of the over temperature switches and/or pressure switches.

**IMPORTANT:** It is recommended that at the beginning of the heating season, the condensate neutralizer if used be replaced by a qualified installer, service agency or the gas supplier.

**IMPORTANT:** It is recommended that an annual inspection and cleaning of all furnace markings be made to assure legibility. Attach a replacement marking, which can be obtained through the distributor, if any are found to be illegible or missing.

## REPLACEMENT PARTS

Contact your local distributor for a complete parts list.

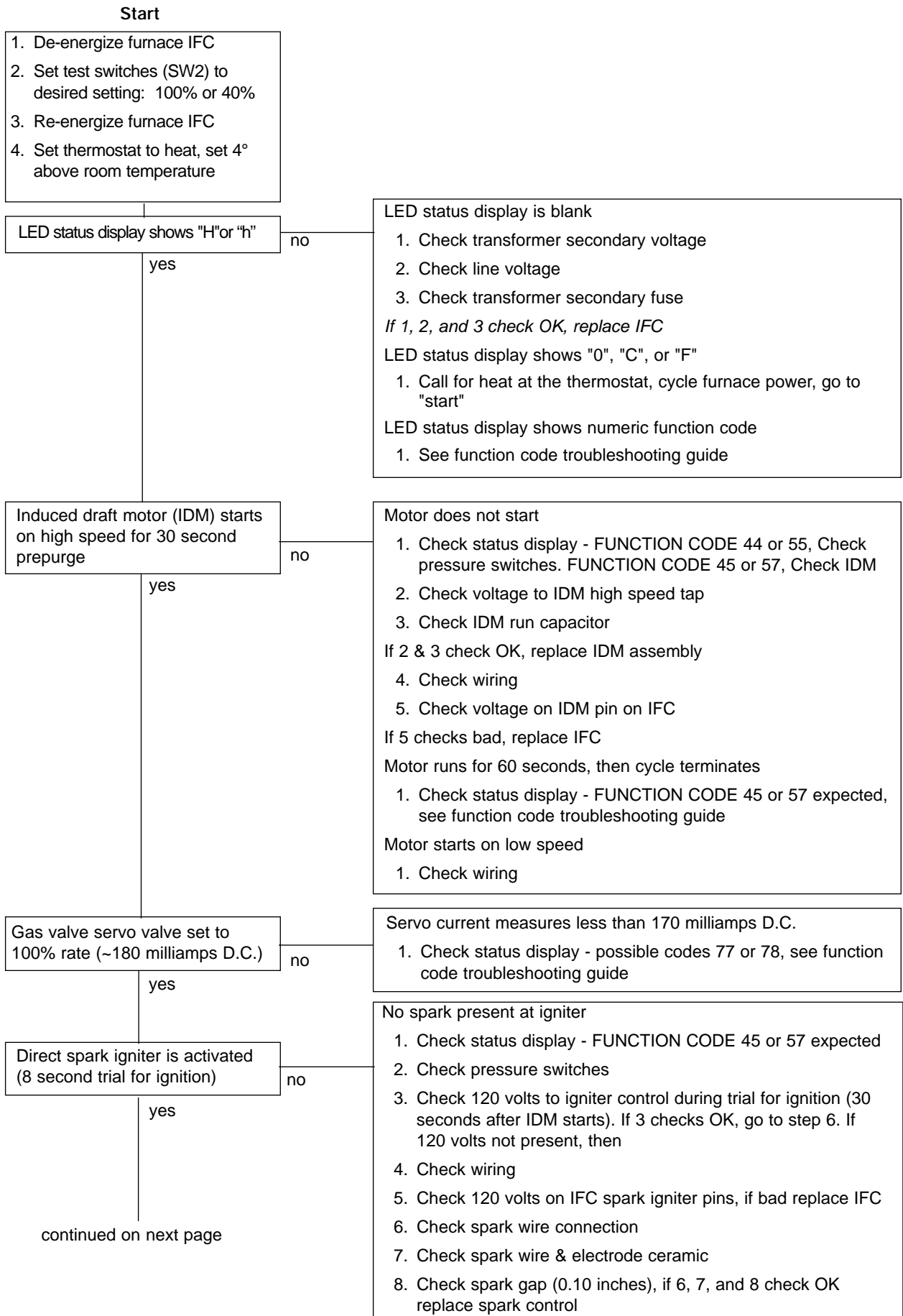
## TROUBLESHOOTING

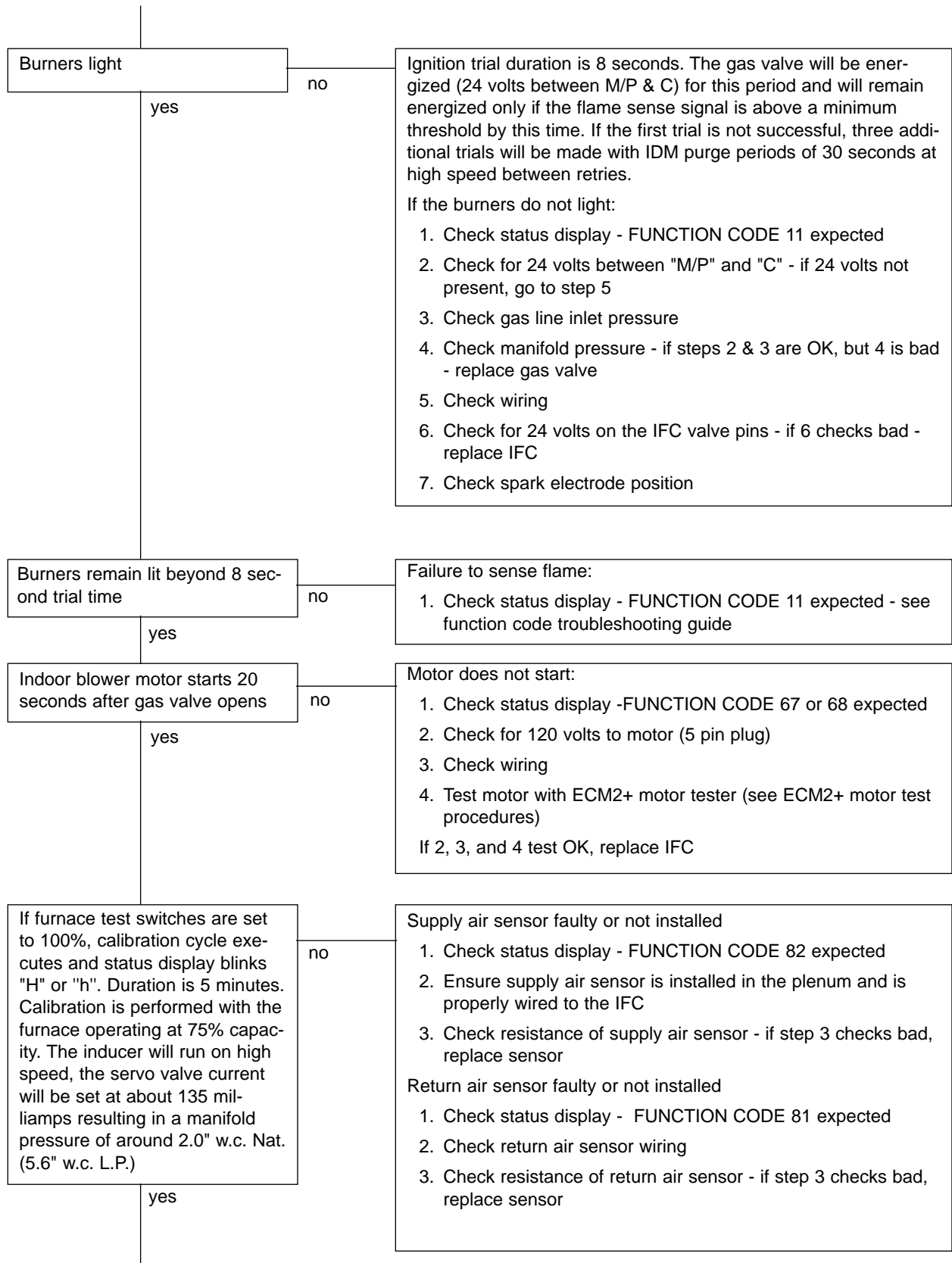
Figure 64 is a troubleshooting flow-charts for the sequence of operation. Table 21 is for fault-code descriptions.

## WIRING DIAGRAM

Figure 65 is a complete wiring diagram for the furnace and power sources.

**FIGURE 64**  
SEQUENCE OF OPERATION TROUBLESHOOTING FLOWCHART





continued on next page

**FURNACE TEST SWITCHES SET AT 100 %**

Furnace runs at 100% rate, status display shows "H" or "h", inducer on high speed, servo current is ~180 milliamps, manifold pressure is ~3.5 " w.c. and temperature rise is 40 - 70 °F

no

Monitor status display for abnormal indications, see function code troubleshooting guide

**FURNACE TEST SWITCHES SET AT 40 %**

Furnace runs at 40% rate, status display shows "H" or "h", inducer on low speed, servo current is ~ 72 milliamps, manifold pressure is ~0.6 " w.c. and temperature rise is 40 - 70°F

no

Monitor status display for abnormal indications, see function code troubleshooting guide

Terminate test mode

1. Test mode times out in 60 minutes.
2. Remove the call for heat from the W terminal

yes

yes

LED status display shows "O" gas valve off, flames off

no

Status display shows "C", "F", or "H"

1. Ensure thermostat is off
2. Check thermostat wiring

Flames remain on

1. Check 24 volts to gas valve solenoids (M/P) - if present, go to step 2, if 24 volts is not present, shut off gas and replace the gas valve
2. Check wiring
3. Check 24 volts on IFC valve pins (MV) - if status display shows "O" and 24 volts is present in step 3, replace IFC

yes

Induced draft motor stops after 20 seconds

no

Induced draft motor doesn't stop

1. Check status display - FUNCTION CODE 22 or 33 expected
2. Check over-temperature switch(es)
3. Check wiring

If steps 2 & 3 check OK, replace IFC

yes

ECM2+ indoor blower motor stops after 90 seconds

no

ECM2+ indoor blower motor does not stop running

1. Check status display - FUNCTION CODE 22, 23 or 33 expected
2. Check main limit and over temperature switch(es)
3. Test motor with ECM2+ motor tester (see ECM2+ motor test procedures)

If steps 2 & 3 check OK, replace IFC

yes

Troubleshooting ends

To return system to modulating/single-stage operation (SW2):

1. De-energize IFC
2. Set furnace test switches (SW2) for desired operation
3. Re-energize IFC
4. Set thermostat for desired operation

**REPEAT PROCEDURE UNTIL TROUBLE-FREE OPERATION IS OBTAINED IN 100% AND 40% TEST MODES**

**TABLE 21**  
**FAULT CODE TROUBLESHOOTING CHART**

Function Code	Description	Response Comments	Probable Causes	Solutions
I	One-Hour Retry	A furnace fault has caused the controller to execute a one-hour retry mode.	A. Failed ignition trial four times (code 11) B. Lost flame sense four times (code 13)	1. Check for function code 11 in buffer. See solutions for function code 11. 2. Check for function code 13 in buffer. See solutions for function code 13.
—	Internal fault	Failed microprocessor self test or main gas valve safety circuit fault. Hard lockout	A. Voltage sensed on the MV output B. Software Self-test output	1. Check for mis-wiring in furnace 2. Replace IFC
<b>11</b>	Failed Ignition Trial	No flame sense during ignition trial. Remains displayed until successful ignition, one hour retry is started or heat demand is removed  Fault is stored in buffer after four consecutive failed ignition trials in a single heat call	A. Insufficient line gas pressure	1. Insure gas supply is connected to furnace and check for proper line pressure
			B. Gas valve control turned "OFF"	1. Turn gas valve to the "ON" position
			C. Insufficient manifold pressure, gas valve "ON"	1. Check 24 VAC to gas valve. 2. Check for 170 - 190 mAmps to servo valve. 3. Adjust valve for proper manifold pressure at 100% rate 4. If gas valve will not adjust, replace gas valve.
			D. No spark at electrodes	1. Check 120 VAC at igniter control during ignition trial. 2. Check spark wire connection at igniter control transformer and electrode. 3. Check for short to ground of electrode (cracked ceramic, touching burners, etc.) 4. Check igniter wire for damage. 5. If all checks OK, replace igniter control
			E. Burners don't light	1. Check for proper mounting and placement spark electrode assembly. 2. Check for proper mounting of burner assembly.
			F. Burners light, but extinguish after 8 seconds or less	1. Check for proper polarity of line voltage. 2. Check flame sensor wiring and connections. 3. Check for improperly mounted flame sensor (positioned out of flame, grounded). 4. Check flame sense current. 5. Clean flame sensor rod.
<b>12</b>	Low Flame Sense	Flame sense level is below predetermined threshold but above minimum operating threshold. Remains displayed until flame sense level rises above threshold level or heat demand is removed.	A. Flame sensor contaminated	1. Clean flame sensor rod
			B. Flame Sensor improperly mounted or grounded	1. Re-install / replace flame flame sensor, check wiring and connections.

**TABLE 21**  
**FAULT CODE TROUBLESHOOTING CHART, CONT.**

Function Code	Description	Response Comments	Probable Causes	Solutions
<b>13</b>	Lost Flame Sense	<p>Flame sense is below minimum operating threshold during a heating cycle. Remains until a successful ignition sequence, one hour retry is started or the heat demand is removed.</p> <p>Fault is stored in buffer after four ignition retries in a single heat call.</p>	A. Flame sensor contaminated	1. Clean flame sensor rod
			B. Flame sensor improperly mounted or grounded	1. Re-install / replace flame sensor, check wiring and connections.
			C. Unstable flame pattern	<ol style="list-style-type: none"> <li>1. Check that all burner assembly components are properly installed.</li> <li>2. Check that all seals between the vestibule area and the heat exchanger area are tight</li> <li>3. Insure that the combustion door gasket is in place and the door is properly installed.</li> </ol>
<b>14</b>	Improper Flame Sense	<p>Flame sensed when gas valve is off. Remains displayed until flame sense signal is gone.</p>	A. Flame remains lit in "OFF" cycle	<ol style="list-style-type: none"> <li>1. Repair mis-wiring to remove continuous 24V to valve.</li> <li>2. Gas valve stuck open - remove and replace.</li> </ol>
			B. Flame goes out in "OFF" cycle	1. Replace IFC board
<b>22</b>	High Limit	<p>High limit circuit is open. Remains displayed until circuit is sensed closed.</p>	A. No airflow	<ol style="list-style-type: none"> <li>1. Check Fault Buffer for ECM motor fault history</li> <li>2. Check ECM motor wiring to the control board.</li> <li>3. Test ECM motor and replace if faulty.</li> </ol>
			B. Insufficient airflow	<ol style="list-style-type: none"> <li>1. Check Fault Buffer for ECM motor fault history</li> <li>2. Check filters and duct work for restrictions</li> <li>3. Check rate and outlet air temperature at 100%, and 40%, compare to maximum on nameplate</li> <li>4. Run furnace calibration and re-check outlet air temperature</li> </ol>
			C. Faulty limit control	1. Replace limit control
			D. Input rate too high.	<ol style="list-style-type: none"> <li>1. Insure properly sized orifices installed.</li> <li>2. Check manifold pressure and adjust as needed.</li> </ol>
<b>23</b>	Auxiliary Limit (HALC)	<p>Auxiliary limit circuit is open. Remains displayed until circuit is sensed closed.</p>	A. On upflow furnaces jumper loose, broken or missing	1. Repair jumper between pins 5 & 11 on J1.
			B. On downflow furnace, faulty HALC.	1. Replace Limit.
			C. On downflow furnaces, no airflow	<ol style="list-style-type: none"> <li>1. Check Fault Buffer for ECM motor fault history</li> <li>2. Check ECM motor wiring to the control board.</li> <li>3. Test ECM motor and replace if faulty.</li> </ol>

**TABLE 21**  
**FAULT CODE TROUBLESHOOTING CHART, CONT.**

Function Code	Description	Response Comments	Probable Causes	Solutions
<b>33</b>	Over-Temperature Limit	Over-temperature limit circuit is open. Remains displayed until circuit is sensed closed.	<p>A. Faulty limit control</p> <p>B. Insufficient combustion air</p> <p>C. Unstable flame pattern</p>	<p>1. Replace limit control.</p> <p>1. Check that inducer is operating at proper speed and RPM.                  2. Insure venting does not exceed the maximum lengths specified in the venting instructions.                  3. Check that all gaskets between the inducer and the center panel / heat exchanger are properly installed and no leaks exist</p> <p>1. Check that all burner assembly components are properly installed.                  2. Check that all seals between the burner compartment and the heat exchanger area are tight.                  3. Insure that the door seals are in place and the door is properly installed.                  4. Check that the heat exchanger has not been damaged; i.e. crushed tubes, breached collector boxes</p>
<b>44</b>	LPS –Contacts Closed	Low pressure switch circuit is closed when no call for heat. Remains displayed until circuit opens or heat demand is removed.	<p>A. Faulty wiring</p> <p>B. Faulty switch</p> <p>C. Abnormally high negative pressure present on vent system</p>	<p>1. Check for shorted wires to the low pressure switch</p> <p>1. Replace low pressure switch</p> <p>1. Check for proper venting and termination as defined in the furnace installation instructions</p>
<b>45</b>	LPS – Open – IDM=HI	Low pressure switch circuit is open during high speed IDM operation. Remains displayed until a successful ignition sequence or the heat demand is removed	<p>A. Insufficient combustion airflow</p> <p>B. Insufficient combustion air</p> <p>C. Improper pressure switch setting</p>	<p>1. Check for leaking hoses or leaking gasket at the induced draft blower</p> <p>1. Replace Low Pressure Switch</p>



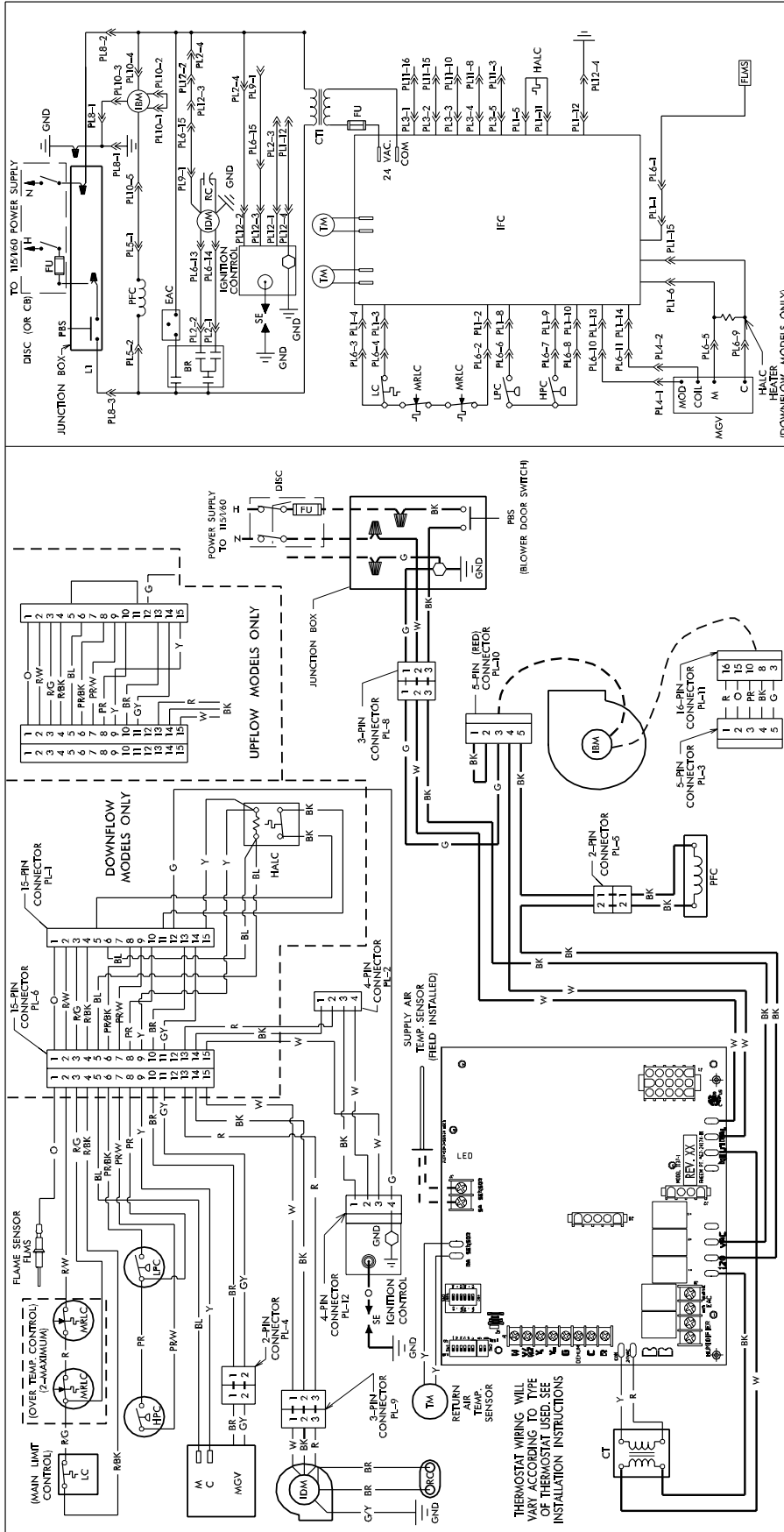
**TABLE 21**  
**FAULT CODE TROUBLESHOOTING CHART, CONT.**

Function Code	Description	Response Comments	Probable Causes	Solutions
<b>46</b>	Auxiliary Limit LPS - Open - IDM = LO	Low pressure switch circuit is open during low speed IDM operation. Remains displayed until a successful ignition sequence or the heat demand is removed	A. Insufficient combustion airflow	<ol style="list-style-type: none"> <li>1. Check that the maximum vent length for the application has not been exceeded and that the vent is properly terminated</li> <li>2. Check that the combustion air inlet and vent pipes are not restricted</li> <li>3. Check that the induced draft motor is operating at the proper speed.</li> </ol>
			B. Condensate not draining from heat exchanger	<ol style="list-style-type: none"> <li>1. Check drain lines for blockage, kinks or double traps</li> <li>2. Insure drain trap has been filled with water before operation</li> </ol>
			C. Insufficient pressure sensed at switch	<ol style="list-style-type: none"> <li>1. Check for leaking hoses or leaking gasket at the induced draft blower</li> </ol>
			D. Improper pressure switch setting	<ol style="list-style-type: none"> <li>1. Replace Low Pressure Switch</li> </ol>
			E. Faulty switch	<ol style="list-style-type: none"> <li>1. Replace Low Pressure Switch</li> </ol>
<b>55</b>	HPS – Contacts Closed	High pressure switch circuit is closed with no call for heat. Remains displayed until circuit opens or heat demand is removed.	A. Faulty wiring	<ol style="list-style-type: none"> <li>1. Check that the wires to the high pressure switch have not been shorted together</li> </ol>
			B. Faulty switch	<ol style="list-style-type: none"> <li>1. Replace high pressure switch</li> </ol>
<b>56</b>	HPS - Closed - IDM = LO	High pressure switch circuit is closed during low speed IDM operation. Remains displayed until heat demand is removed	A. Minimum vent requirements not followed	<ol style="list-style-type: none"> <li>1. Insure vent system has minimum recommended vent lengths.</li> <li>2. Insure vent system is properly terminated.</li> <li>3. Insure combustion compartment door is properly installed.</li> </ol>
			B. Improper switch setting	<ol style="list-style-type: none"> <li>1. If high altitude pressure switch is installed and installation site elevation is near 5,000 feet, check cold pressures on high speed inducer to insure pressure switch change was necessary.</li> <li>2. Replace high pressure switch as needed.</li> </ol>
<b>57</b>	HPS – Open – IDM=HI	High pressure switch circuit is open during high speed IDM operation. Remains displayed until a successful ignition sequence or the heat demand is removed.	A. Insufficient combustion airflow	<ol style="list-style-type: none"> <li>1. Check that the maximum vent length for the application has not been exceeded and that the vent is properly terminated</li> <li>2. Check that the combustion air inlet and vent pipes are not restricted</li> <li>3. Check that the induced draft motor is operating at the proper speed.</li> </ol>
			B. Condensate not draining from heat exchanger	<ol style="list-style-type: none"> <li>1. Check drain lines for blockage, kinks or double traps</li> <li>2. Insure drain trap has been filled with water before operation</li> </ol>
			C. Insufficient pressure sensed at switch	<ol style="list-style-type: none"> <li>1. Check for leaking hoses or leaking gasket at the induced draft blower</li> </ol>
			D. Improper pressure switch setting	<ol style="list-style-type: none"> <li>1. Replace High Pressure Switch</li> </ol>
			E. Faulty switch	<ol style="list-style-type: none"> <li>1. Replace High Pressure Switch</li> </ol>

**TABLE 21**  
**FAULT CODE TROUBLESHOOTING CHART, CONT.**

Function Code	Description	Response Comments	Probable Causes	Solutions
<b>66</b>	ECM – RPM Range	ECM feedback signal indicated the indoor blower motor RPM is above 1200. Remains displayed until RPM returns to normal operating range or blower operation requirement is removed.	A. ECM motor operating at RPM limit. B. Unit installed in a “normal extreme” installation (see solution #5)	1. Check for dirty filter 2. Check for inadequate return air supply 3. Check for under-sized duct work 4. Check for loose blower wheel 5. Unit installation is at environmental limits of: altitude, system static pressures, high efficiency air filters, etc. Blower demand requires operation at RPM limit.
				1. Check motor part number, replace motor if needed. 2. Test motor feedback signal, replace if faulty
<b>67</b>	ECM – Improper Signal	ECM Feedback signal does not follow defined protocol – RPM / CFM blink. Remains displayed until feedback is corrected or blower operation requirement is removed.	A. Wrong ECM motor installed	1. Ensure the ECM wiring harness is complete and connected
			B. Faulty ECM motor	1. Test motor for feedback signal, replace motor if faulty.
			C. Faulty control board	1. Replace control board if necessary
<b>77</b>	GV Servo – Open	Gas valve servo circuit is sensed open. Remains displayed until circuit is closed or heat demand is removed.	A. Faulty wiring	1. Ensure continuity from board connector to gas valve and to ground, check all connections.
			B. Faulty gas valve	1. Check resistance of servo-valve coil. Replace valve if out of tolerance.
			C. Faulty control board	1. Replace control board if faulty.
<b>78</b>	GV Servo – Control Fault	Gas valve current sensing circuit tests out of range. Remains displayed until circuit tests OK or heat demand is removed.	A. Gas valve servo coil out of specification	1. Conduct the following test: a. Turn the gas valve control knob to the off position. b. Disconnect servo valve connector and place a 100-Ohm, 10-Watt resistor across the two wires from the furnace wiring harness (not the wires from the gas valve). c. Set the furnace to attempt another ignition cycle. d. If Function code 78 appears, replace the IFC. e. If Function code 11 appears, replace the gas valve
			B. Faulty wiring	1. Ensure continuity from board connector to gas valve and to ground, check all connections.
			C. Sensor Not Connected or not used	1. Check resistance of thermistor. Replace sensor if out of tolerance. 2. Reconnect sensor if used. If not used, then furnace is operating normally.
<b>81/82</b>	RAS / SAS – Out of Range	Return / Supply air sensor out of range. Remains displayed for 1.5 minutes after power on. After that time codes remain in memory but are not displayed. Recycling the power will redisplay codes.	A. Faulty wiring	1. Ensure continuity from board connector to gas valve and to ground, check all connections
			B. Faulty Thermistor Assembly	1. Check resistance of thermistor. Replace sensor if out of tolerance
			C. Sensor Not Connected or not used	2. Reconnect sensor if used. If not used, then furnace is operating normally.

**FIGURE 65**  
**WIRING DIAGRAM**



**WIRE COLOR CODE**

BK	BLACK
OR	ORANGE
PR	PURPLE
BR	BROWN
BL	BLUE
R	RED
W	WHITE
Y	YELLOW
GY	GRAY

**ELECTRICAL WIRING DIAGRAM**  
UPFLOW /DOWNFLOW  
BLOWER INDUCED DRAFT  
MODULATING  
GAS FIRED FORCED  
AIR FURNACE  
WHITE-RODGERS GAS VALVE  
DIRECT SPARK IGNITION

**WIRING INFORMATION**

LINE VOLTAGE  
-FACTORY STANDARD  
-FACTORY OPTION  
-FIELD INSTALLED

LOW VOLTAGE  
-FACTORY STANDARD  
-FACTORY OPTION  
-FIELD INSTALLED

REPLACEMENT WIRE  
-MUST BE THE SAME SIZE AND TYPE OF INSULATION AS ORIGINAL (1005 C° MIN.)

WARNING  
-CABINET MUST BE PERMANENTLY GROUNDED AND CONFORM TO I.E.C., N.E.C., C.E.C. AND LOCAL CODES AS APPLICABLE.

**NOTES:**

LOW PRESSURE CONTROL  
MAIN GAS VALVE  
MAIN RESET LIMIT CONTROL  
PUSH BUTTON SWITCH  
POWER FACTOR CHOKE  
PLUG  
RUN CAPACITOR  
IBM  
INDUCED DRAFT MOTOR  
THERMISTOR  
WIRE NUT

**COMPONENT CODE**

C	COMMON
CT	CONTROL TRANSFORMER
DISC	DISCONNECT SWITCH
FLMS	FLAME SENSOR
FUSE	FUSE
GND	GROUND
HALC	HEAT ASSISTED LIMIT CONTROL
HPC	HIGH PRESSURE CONTROL
IBM	INDUCED DRAFT MOTOR
IDM	INDUCED DRAFT MOTOR
IFC	INTEGRATED FURNACE CONTROL
LC	LIMIT CONTROL
LPC	LOW PRESSURE CONTROL
M	MAIN GAS VALVE
MGV	MAIN GAS VALVE
MRLC	MAIN RESET LIMIT CONTROL
PBS	PUSH BUTTON SWITCH
PFC	POWER FACTOR CHOKE
PL	PLUG
RC	RUN CAPACITOR
PL	PLUG
SE	SPARK ELECTRODE
TM	THERMISTOR
▲	WIRE NUT

DWG. NO. **90-24216-04** REV **05**

DR. BY **JIM** APP. BY **JIM** DATE **10-3-00** I.D.M.C. NO. **90-24216-04** REV **05**



# THERMOSTAT INSTRUCTIONS



# INSTALLATION INSTRUCTIONS

## PROGRAMMABLE MODULATING THERMOSTAT

(PART # 41-24312-04)

## NON-PROGRAMMABLE THERMOSTAT

(PART #41-25347-01)



**RECOGNIZE THIS SYMBOL AS AN INDICATION OF IMPORTANT SAFETY INFORMATION!**

### **▲ WARNING**

THESE INSTRUCTIONS ARE INTENDED AS AN AID TO QUALIFIED, LICENSED SERVICE PERSONNEL FOR PROPER INSTALLATION, ADJUSTMENT AND OPERATION OF THIS UNIT. READ THESE INSTRUCTIONS THOROUGHLY BEFORE ATTEMPTING INSTALLATION OR OPERATION. FAILURE TO FOLLOW THESE INSTRUCTIONS MAY RESULT IN IMPROPER INSTALLATION, ADJUSTMENT, SERVICE OR MAINTENANCE POSSIBLY RESULTING IN FIRE, ELECTRICAL SHOCK, PROPERTY DAMAGE, PERSONAL INJURY OR DEATH.



ISO 9002

**DO NOT DESTROY THIS MANUAL**

**PLEASE READ CAREFULLY AND KEEP IN A SAFE PLACE FOR FUTURE REFERENCE BY A SERVICEMAN**

# INSTALLING YOUR THERMOSTAT

## WARNING

### SHOCK HAZARD

Disconnect the power supply before any wiring connections or changes are made to prevent electrical shock or possible damage to the equipment. Follow all local electrical codes during installation. All wiring must conform to local and national electrical codes. Improper wiring or installation may damage this product, electrical shock, property damage or death.

## CAUTION

### EQUIPMENT DAMAGE HAZARD

Before connecting the power supply to finished installation, make all wiring connections and VERIFY all connections. Short-circuited or improperly connected wires will result in permanent damage to the unit and void the warranty.

## INTRODUCTION

This thermostat is an electronic 24-VAC, wall-mounted thermostat. It uses two set points to maintain and control room temperature in both the heating and cooling modes. No batteries are required: temperature, fan, mode, and installer configuration settings are preserved if there is a loss of power.

*IMPORTANT: THE 41-24312-04 THERMOSTAT REPLACES ALL PAST THERMOSTATS WITH PART NUMBERS 41-24312-02 AND 41-24312-03 THAT ARE NO LONGER AVAILABLE.*

**THIS THERMOSTAT IS INTENDED FOR USE WITH THE MODULATING HEAT 90 PLUS GAS FURNACE. THIS THERMOSTAT CANNOT BE USED IN HEAT PUMP APPLICATIONS.**

## INSTALLATION CONSIDERATIONS

You should prepare ahead if you are installing any of the options mentioned in other sections of this manual.

If this is a new installation or a replacement, verify:

- the size of wire needed or installed
- length of wire needed (distance from the thermostat and the equipment, and optional equipment)
- if installing any remote temperature sensing equipment (please read the installation instructions packaged with these units before proceeding any further)

The thermostat is to be connected using unshielded (18 AWG minimum) thermostat wire.

## LOCATION

The most important consideration in installing your electronic thermostat is where to locate the unit. The location can radically affect the operation of the thermostat. To ensure proper operation, the thermostat should be mounted on an inside wall, in a frequently occupied area of the building. In addition, its position must be at least 18 inches (46cm) from any outside wall, and approximately 5 feet (1.5m) above the floor in a location with freely circulating air of an average temperature.

### BE SURE TO AVOID THE FOLLOWING LOCATIONS:

- behind doors or in corners where freely circulating air is unavailable
- where direct sunlight or radiant heat from appliances might affect control operation
- on an outside wall
- adjacent to, or in line with, conditioned air discharge grills, stairwells, or outside doors
- where its operation may be affected by steam or water pipes or warm air stacks in an adjacent partition space, or by an area not heated or cooled behind the thermostat
- where its operation will be affected by the supply air of an adjacent unit
- near sources of electrical interference such as arcing relay contacts



# THERMOSTAT INSTALLATION

**IMPORTANT:** WHEN REPLACING AN EXISTING THERMOSTAT, USE WIRE TAGS TO IDENTIFY TERMINAL DESIGNATIONS AS YOU DISCONNECT THE UNIT.

**NOTE:** Before you start, you will need the following supplies:

- Drill
- 3/16 inch (4.7mm) drill bit
- 1/8 inch (3mm) flat blade screwdriver
- Hammer
- Marking pencil
- Wire stripper

## WARNING

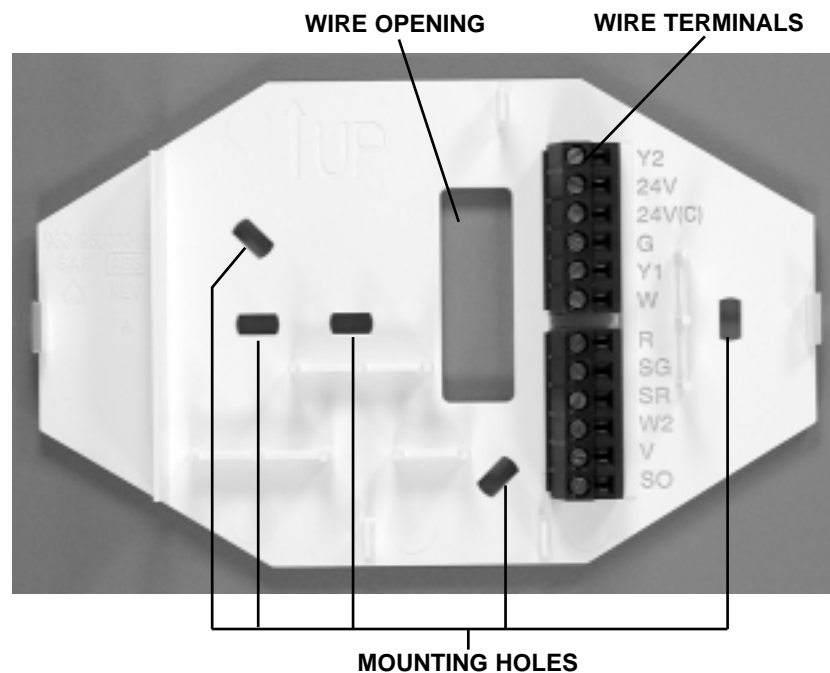
### SHOCK HAZARD

Disconnect the power supply before any wiring connections or changes are made to prevent electrical shock or possible damage to the equipment.

1. Turn OFF power to the unit.
2. If an existing thermostat is being replaced:
  - a. Remove the existing thermostat from wall.
  - b. Disconnect wires from the existing thermostat, one at a time, recording wire color and terminal marking as you go.
  - c. Discard or recycle old thermostat.

**NOTE:** Mercury is a hazardous waste and MUST be disposed of properly. Consult local codes for proper disposal methods.
3. Separate the front plastic assembly of the thermostat from the subbase.
4. Route the thermostat wires through the wire opening in the subbase. Mark the location of the mounting holes you will be using.
5. Drill two 3/16-in. mounting holes in the marked locations.
6. Secure the subbase to the wall with the 2 anchors and screws provided with the thermostat. Make sure that all wires extend through the wire opening in the subbase.
7. Connect wires to the proper terminal locations on the subbase (see Table 1 and Figures 2 & 3).

**FIGURE 1**  
THERMOSTAT SUBBASE



**TABLE 1**  
WIRING INFORMATION

TERMINAL	FUNCTION
Y2	SECOND-STAGE COOLING (EXTERNAL TO FURNACE)
24V	NOT USED
24V(C)	TO "C" TERMINAL, IFC BOARD. TRANSFORMER 24V COMMON
G	TO "G" TERMINAL, IFC BOARD. INDOOR BLOWER.
Y1	TO "YH" TERMINAL, IFC BOARD. COOLING TERMINAL.
W	TO "W" TERMINAL, IFC BOARD. HEATING TERMINAL.
R	TO "R" TERMINAL, IFC BOARD. TRANSFORMER 24V SUPPLY
SN(G)	COMMON TERMINAL FOR ALL REMOTE TEMPERATURE SENSORS.
SN(R)	POWER SUPPLY TERMINAL FOR REMOTE INDOOR TEMPERATURE SENSOR. NOT USED IF REMOTE SENSOR IS NOT USED.
W2	NOT USED.
V	TO "V" TERMINAL, IFC BOARD. PERMITS GAS VALVE MODULATION. ONLY USED WITH MODULATING HEAT FURNACES.
SN(O)	POWER SUPPLY TERMINAL FOR REMOTE INDOOR TEMPERATURE SENSOR. NOT USED IF REMOTE SENSOR IS NOT USED.

8. Push any excess wire back into the wall and seal the hole to prevent air leaks. Leaks can affect thermostat operation.
9. Snap the thermostat together, making sure assembly is secure.
10. Turn ON power to the unit.

## THERMOSTAT WIRING JUMPER "JW1 TWIST OFF" FEATURE

"Twist off" is written on the thermostat printed circuit board subbase, above and to the right of the thermostat vertical 24 volt control wiring terminals. Nearby, is a one-time removable wiring jumper that is ONLY removed when using 2 separate 24-volt control transformers for independent thermostat heating and cooling functions.

**IMPORTANT: DO NOT REMOVE OR TWIST OFF THIS JUMPER WHEN THERMOSTAT IS USED WITH THE MODULATING 90% FURNACE.**

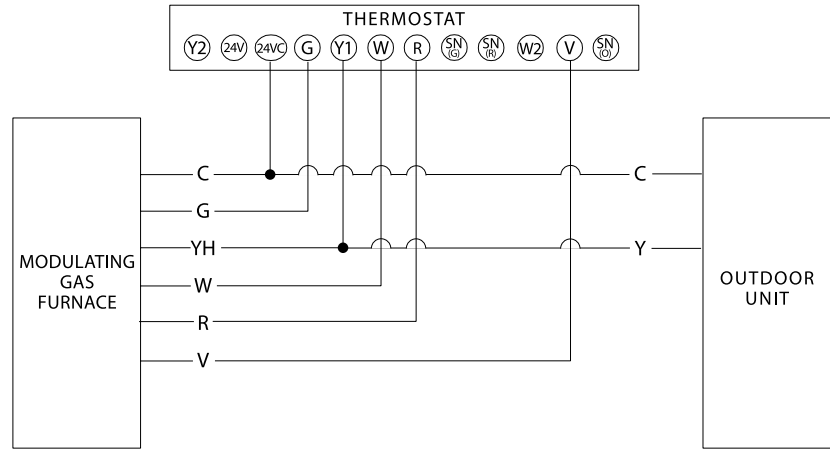
If the twist off jumper is inadvertently removed. The thermostat can continue to be used by placing a jumper wire between the thermostat subbase "24V" and "R" terminals. This will restore the thermostat back to its original wiring configuration for use with a single-control transformer.

## REMOTE INDOOR/OUTDOOR TEMPERATURE SENSOR (PART # 41-25300-04)

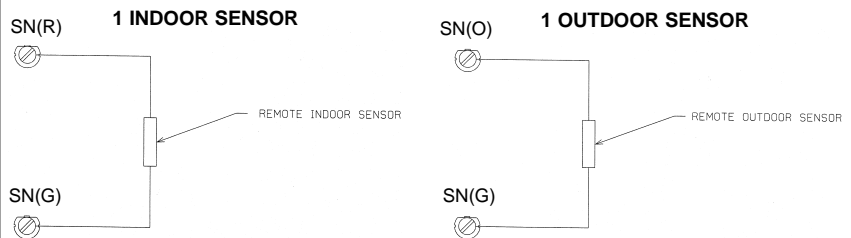
The remote indoor/outdoor sensor is designed for use with your electronic thermostat. It is easy to install and provides accurate digital communication of space temperature back to the controlling thermostat from up to 300 feet, using 2-wire, 18-gauge cable wired directly to the thermostat subbase. When a remote sensor is installed, the on-board temperature sensor is disabled. The thermostat detects the remote sensor connection and controls temperature based on the data received. Up to four (4) remote locations can be monitored. See Figure 3 for wiring information.

**IMPORTANT: USE ONLY THE INDOOR/OUTDOOR SENSOR DESIGNED FOR THIS THERMOSTAT (PART # 41-25300-04). ANY REMOTE OUTDOOR OR INDOOR SENSORS USED WITH PREVIOUSLY INSTALLED SYSTEMS OR DESIGNED FOR USE WITH OTHER THERMOSTATS ARE NOT COMPATIBLE AND CANNOT BE USED WITH THIS THERMOSTAT.**

**FIGURE 2**  
WIRING CONFIGURATION FOR MODULATING 90 PLUS GAS FURNACES (MODULATING HEAT / 1-STAGE COOL)

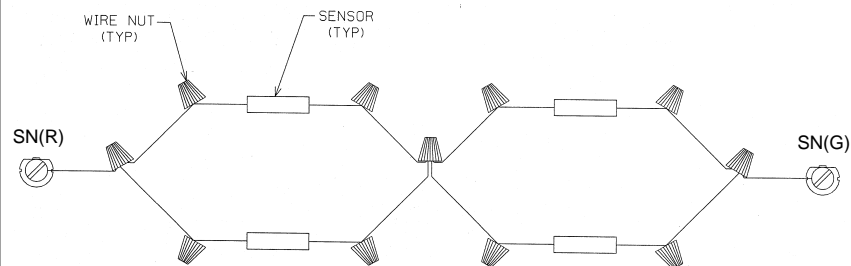


**FIGURE 3**  
WIRING CONFIGURATION FOR REMOTE SENSORS



### MULTIPLE LOCATIONS

If using sensors in multiple locations, 4 sensors must be used. Sensors may be grouped in one cover if only 2 or 3 locations are required.  
**NOTE:** Wiring schematic remains the same no matter how many locations are used.



## THERMOSTAT ADAPTER PLATE (PART # 41-25300-06)

The thermostat adapter plate is used to mount your electronic thermostat over a large hole, or to cover other holes left by the previous thermostat if you are replacing an old thermostat.

# THERMOSTAT CONFIGURATION

## EDITING SETTINGS

(REFER TO FIGURE 4)

1. Enter Configuration Mode by pressing and holding the FAN button for 10 seconds.
2. Use the UP and DOWN buttons to change the Settings Selection Display to the correct setting number.
3. Press the TIME/TEMP button to switch to the Preferences Display area.
4. Use the UP and DOWN buttons to change your preferences as listed in the detailed settings instructions that follow.
5. If no further changes are needed, press the HOLD/END button. If further settings changes are needed, press TIME/TEMP to toggle back to the Setting Selection Display to choose another setting. If no button is pressed for 3 minutes, the thermostat will exit Configuration Mode and return to normal operation.

## CONFIGURATION OPTIONS

Setting 1: Sensitivity adjustment

Setting 3: Fahrenheit or Celsius

Setting 7: Local or remote sensor selection

Setting 8: setpoint anticipator

Setting 9: Programming periods per day

Setting 10: Off-Cycle dehumidification

Setting 13: Local sensor offset

Setting 16: Remote sensor offset

Setting 19: Outdoor sensor offset

**NOTE:** Settings 2, 4, 5, 6, 11, 12, 14, 15, 17, and 18 are not used on this model.

## SETTING 1

### SENSITIVITY ADJUSTMENT

This adjustment controls the cooling sensitivity. Factory default setting for cooling sensitivity is 8. The sensitivity options are:

FIRST STAGE	SECOND STAGE
5 = 0.5°	5 = 1.0°
8 = 0.8°	8 = 1.6°
12 = 1.2°	12 = 2.4°

## SETTING 3

### FAHRENHEIT/CELSIUS

This setting operates the thermostat in either Fahrenheit or Celsius mode. Factory default is Fahrenheit

## SETTING 7

### LOCAL OR REMOTE SENSOR

This selection determines whether the thermostat uses the local on-board temperature sensor or an optional remote room temperature sensor. Factory default is LS.

The sensor options are:

LS = Local Sensor

RS = Remote Sensor

## SETTING 8

### SETPOINT ANTICIPATOR

This selection determines when the program schedule time takes effect. If set to ON the thermostat will look ahead 60 minutes into the program schedule and slowly ramp the setpoint to satisfy demand before the program period. If this setting is OFF the program schedule will switch to the scheduled temperature at the scheduled time without ramping the setpoint. The factory default is ON.

The setpoint anticipator options are:

ON = Anticipate setpoint change

OFF = Do not anticipate setpoint change

## SETTING 9

### PROGRAM SCHEDULE PERIODS

This setting determines the number of program periods in the program schedule (2 or 4). Factory default 4.

## SETTING 10

### OFF-CYCLE DEHUMIDIFICATION (OCD)

This setting enables or disables OCD. Factory default is ON.

The OCD feature allows the unit to run when there has been no call for cooling and high humidity is present. It does this by sensing the space temperature and comparing that to the set point temperature. It also uses the time elapsed since the last cooling call ended.

OCD activates if the last call for cooling ended at least 75 minutes ago and the space temperature is below the set point. The thermostat calls for cooling and runs the blower at 85% of its normal cooling CFM. This cools and dehumidifies the space air. The equipment runs for 15 minutes then stops.

OCD will be canceled if the space temperature drops 2.5°F below set point, the thermostat mode is changed, or if a call for cooling occurs. This feature will not be turned on at the factory. The homeowner must turn the feature on for it to become active. Check instructions supplied with the thermostat to determine how to do this.

## SETTING 13

### LOCAL SENSOR OFFSET

This setting allows the room temperature display to be adjusted by +/- 5 degrees. The factory default is 0.

**NOTE:** Do not adjust for 30 minutes after installation because the board may be heated by handling. The selected number is the number of degrees, plus or minus, which will be added to the actual temperature. The numbers can range between -5 and +5.

## SETTING 16

### REMOTE SENSOR OFFSET

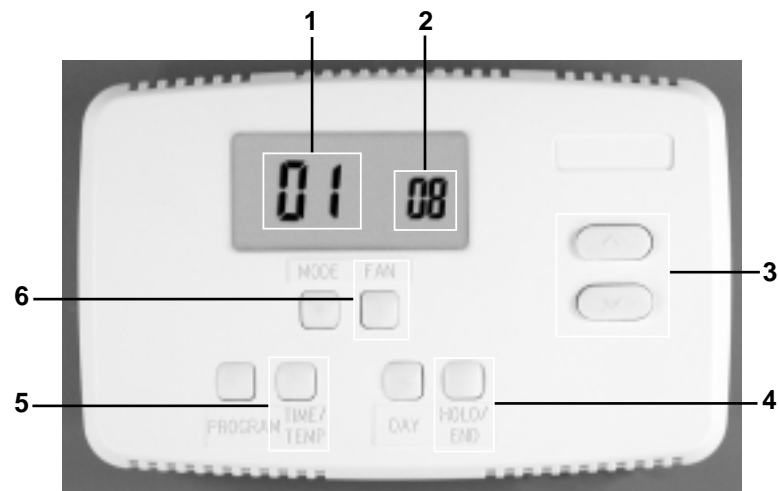
This setting allows the room temperature display to be adjusted by +/- 5 degrees. The factory default is 0.

## SETTING 19

### OUTDOOR SENSOR OFFSET

This setting allows the outdoor temperature display to be adjusted by +/-5 degrees. The factory default is 0.

**FIGURE 4**  
THERMOSTAT - CONFIGURATION MODE



1. Setting Selection Display

2. Preferences Display

3. UP/DOWN Selection Buttons

4. HOLD/END Button

5. TIME/TEMP button

6. FAN button

# THERMOSTAT OPERATION (REFER TO FIGURE 5)

## POWER UP

When power is first applied, "rh" will appear for 5 seconds in the Temperature Display area of the LCD screen while the thermostat initializes.

## SETTING CURRENT TIME

1. Press the TIME/TEMP button. SET TIME will flash on the display.
2. Press the UP or DOWN buttons until the correct time is displayed. Holding either button down will allow the value to scroll in the display.
3. When the correct time appears on the display, press the HOLD/END button. (NOTE: If you choose not to press the HOLD/END button, the thermostat will automatically exit the time setting mode after 10 seconds).

## SETTING CURRENT DAY

Press the DAY button to advance to the correct day.

## MANUAL OPERATION

To operate the thermostat manually without a pre-programmed comfort schedule, press the HOLD/END button. The HOLD icon will appear in the LCD Display and the clock will be hidden to indicate that you are no longer following a programmed schedule.

### TO SELECT THE MODE:

Use the mode button to move between the choices. OFF, AUTO, HEAT, or COOL will appear on the display.

### TO SELECT THE FAN OPERATION

Use the FAN button to move between continuous fan (indicated by the FAN ON icon) and auto fan operation.

### TO READ ROOM TEMPERATURE:

The large display reads room temperature until a button is pressed.

### TO ADJUST SETPOINT:

Pressing either the UP or DOWN buttons once will show the current setpoint. The current setpoint will be displayed for a period of 5 seconds. Successive press within 5 seconds will adjust the setpoint. The SET TEMP icon will flash on the LCD Display while setpoint adjustments are being made. Five seconds of inactivity will return the thermostat to room temperature display mode.

## AUTO MODE

This product can control heating/cooling set points simultaneously using Auto mode. Auto mode will switch between heating and cooling as required. The minimum difference between the heating and cooling set points is 2 degrees.

## PROGRAMMED OPERATION

The thermostat provides 2 or 4 periods per day (MORNING, DAY, EVE, NIGHT, or DAY, NIGHT) as configured by your installer. Seven schedules per week (one for each day) are available. A separate time, heat setpoint, and cool setpoint can be set for each period and schedule. Set point can be set for each period and schedule.

The first press of the PROGRAM button will bring up the programming mode and place you at the current day. Successive presses will switch between the four daily periods.

## WHILE PROGRAMMING

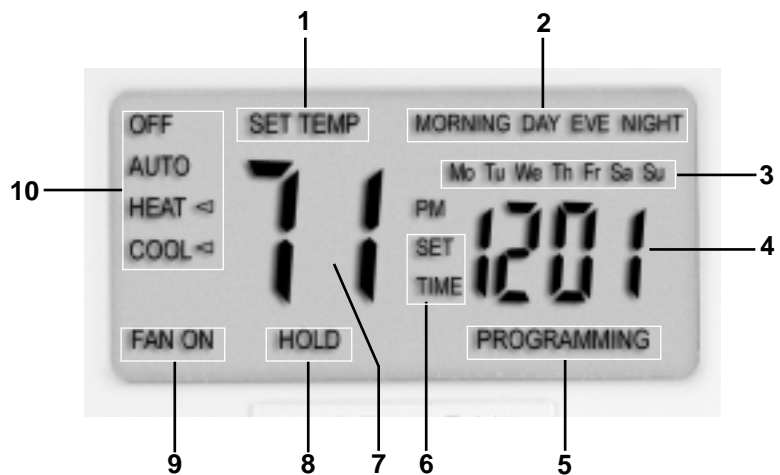
- The TIME/TEMP button will toggle between the SET TIME and SET TEMP modes.
- The MODE button toggles between HEAT and COOL setpoints. These three numbers can be programmed for each of the periods.
- The DAY button changes the day of the week.

- Exit programming at any time by pressing the HOLD/END button.

## PROGRAMMING A COMFORT SCHEDULE

1. Press the PROGRAM button. The word PROGRAMMING will appear on the display and the words SET TIME will flash on the display. the day of the week and the present period icons will appear on the display. The current mode (HEAT or COOL) will also show. Use the DAY button to select the desired day and the PROGRAM button to select MORNING.
2. Press the UP or DOWN button to select the cooling temperature setpoint.
3. Press the MODE button until COOL is displayed. Press TIME/TEMP until SET TEMP flashes on the display.
4. Press the UP or DOWN button to select the cooling temperature setpoint.
5. Press the MODE button until HEAT is displayed. Press TIME/TEMP until SET TEMP flashes on the display.
6. Press the Up or DOWN buttons to select the heating temperature setpoint.

FIGURE 5  
THERMOSTAT LCD DISPLAY



1. Set Temperature
2. Program Period
3. Days of Week
4. Time of Day
5. Programming Mode
6. Set Time of Day
7. Temperature Display
8. Hold Status
9. Fan Status
10. Mode Setting

7. Press the PROGRAM button to advance to the next time period. Enter the remaining time and temperature settings for the periods DAY, EVE, and NIGHT by following steps 2 through 6 above.
8. Press the DAY button to change between days. To set another days schedule, repeat steps 2 through 7.
9. Press HOLD/END to exit the programming mode.

### COPY PREVIOUS DAY

When the last period parameters for the current day have been programmed, the user can press the DAY and UP buttons simultaneously to copy the current day schedule into the next day.

### MODIFYING YOUR WEEKLY COMFORT SCHEDULE

If you choose to change any of the schedule settings, press PROGRAM at any time. You will enter the programming schedule at the present day, present mode, in the morning period. You are ready to set the new starting time for the morning period. Follow the steps listed above to change the schedule values.

### OVERRIDING YOUR COMFORT SCHEDULE

There are two ways to override your comfort schedule:

#### METHOD 1—MANUAL OPERATION

Pressing the HOLD/END button will turn on the HOLD icon. The thermostat will maintain the current temperature settings and ignore the comfort schedule for an indefinite period of time. The word HOLD will appear in the display and the clock digits will be hidden. Press the HOLD/END button a second time and the thermostat will return the temperature settings to the programmed comfort schedule and display the clock. Pressing HOLD/END will not alter your programmed comfort schedule.

#### METHOD 2—TEMPORARY OVERRIDE

At the first press of the UP or DOWN button, the current temperature setting will appear on the display. Pressing the UP or DOWN button again will temporarily change the setpoint as needed. At the next programmed time, the programmed comfort schedule will be used.

## ADVANCED THERMOSTAT OPERATION

REFER TO FIGURE 5

### TEMPERATURE DISPLAY

The thermostat will display room temperature until either the UP or DOWN button is pressed. The words SET TEMP will appear when these buttons are pressed. The current setpoint will be displayed. If no buttons are pressed for 5 seconds, the display will return to room temperature display mode.

**IF OPTIONAL OUTDOOR SENSOR IS INSTALLED:** To display the outdoor temperature, press and hold the UP and DOWN keys at the same time. Display will return to normal after 4 seconds.

### TIMEGUARD TIMER

A 5-minute timeguard is built into the thermostat and is initiated automatically upon power up, and any time the compressor turns off. The compressor will not turn on until the timeguard has expired. The timeguard affects only compressor operation. Pressing the UP and FAN buttons simultaneously overrides the timeguard for 1 cycle.

### CYCLE TIMER

In normal heating and cooling operation, the thermostat will not allow more than 4 equipment cycles per hour (or 1 cycle every 15 minutes). Both the Y and W outputs have a 15-minute timer that begins to count down when the output is turned on. Pressing the UP and FAN buttons simultaneously or changing the setpoint will override the timer for 1 cycle.

### MINIMUM-ON TIMER

Once the equipment has turned on, it will remain on for a minimum of 3 minutes regardless of demand. However, the equipment can turn off in less than 3 minutes if a change in setpoint or a change in mode occurs.

### STAGING TIMER

There is a 15-minute delay between the first and second stages of cool (i.e. Y1 to Y2).

### ERROR MESSAGES

**E4** will be displayed if the thermostat has an internal memory failure. If E4 appears, replace thermostat.

-- (dashes) will be displayed if the thermostat cannot properly read temperature. If -- appears, replace either the thermostat or the sensor in error (remote or outdoor air).

## CHECKING THERMOSTAT OPERATION

REFER TO FIGURE 5

### FAN OPERATION

1. Press FAN button. This will start continuous fan operation. FAN ON icon will be displayed.
2. Press FAN button again. This will stop continuous fan operation. The FAN ON icon will turn off.

### HEATING OPERATION

1. Press MODE button until HEAT is displayed.
2. Press UP button until LCD display reads 3° above room temperature. Press UP and FAN buttons simultaneously to defeat timers. Heating system should begin to operate immediately.

### COOLING OPERATION

1. Press the MODE button until COOL is displayed.
2. Press the DOWN button until the LCD display reads 3° below room temperature. Press UP and FAN buttons simultaneously to defeat timers. Cooling system should begin to operate immediately.

### FIRING RATE

This thermostat mode indicates the modulating furnace heating capacity in 5% firing rate increments ranging from 35% to 95%.

The furnace will fire at 40% capacity if the thermostat indicates 35%, 40% or 45% heating capacity.

Beginning at the 50% firing rate, the furnace fires in 5% increments up to 95% heating capacity.

The furnace fires at 90% heating capacity at the thermostat-indicated 90% heating capacity. The furnace fires at 100% heating capacity at the thermostat-indicated 95% heating capacity.

**NOTE:** Although the furnace is actually firing at 100% capacity, the thermostat will not indicate over 95% heating capacity.

1. Place thermostat in heating mode.
2. Press and hold the TIME/TEMP button for 10 seconds until display reads 35. Though the thermostat may read 35%, the furnace will not fire below 40% heating capacity.
3. To raise or lower the firing rate, press the up or down arrows.
4. To exit, press the HOLD/END button.

# PROGRAMMABLE THERMOSTAT TROUBLESHOOTING GUIDE

This chapter is devoted to troubleshooting various operating problems that may occur. It suggests actions that may be taken to correct problems and return the thermostat to operational status.

To start the troubleshooting procedure, a thorough visual inspection must be made to determine if the malfunction is caused by some obvious defect (i.e., damaged component, loose wire connection, etc ...).

Table 2 does not list all the symptoms and probable causes, only those most probable. Various combinations of malfunctions are also possible.

**TABLE 2**  
PROGRAMMABLE THERMOSTAT TROUBLESHOOTING TABLE

<b>SYMPTOM</b>	<b>POSSIBLE CAUSE</b>	<b>CORRECTIVE ACTION</b>
<b>1 - No display / faint display</b>	1a- Supply voltage incorrect	1a- Use a voltmeter to check between the 24V and 24V(c) terminals located on the thermostat subbase. Voltage should read between 20VAC to 30VAC. If the voltage is less than 20VAC, disconnect the thermostat and verify the voltage between 24V and the other equipment wires; see possible causes 1b and 1c. If voltage is greater than 30VAC, troubleshoot the power source and replace the thermostat.
	1b- System transformer weak or overloaded	1b- Check and / or replace with a suitable 24 Volt transformer
	1c- Thermostat damaged because system voltage was greater than 30VAC	1c- Replace with new thermostat, and ensure new thermostat is isolated from the system using suitable relays and a transformer of the proper rating.
<b>3 - LCD display has missing or extra segments displayed</b>	3a- LCD failure	3a- Replace the thermostat
<b>4 - Temperature display is incorrect</b>	4a- The thermostat is set in either F or C display	4a- Verify whether the thermostat is set to display °C or °F.
	4b- Poor thermostat location	4b- Relocate the thermostat to a better location.
	4c- Local Sensor Offset is too high	4c- Modify Setting 13 per the instructions in this manual.
<b>5 - Fan does not activate with the system equipment</b>	5a- Fan failure	5a- Place a jumper between terminal blocks R and G. Fan should activate. If it does not, troubleshoot the fan system; if fan does activate, replace the thermostat.
<b>6 - Fan does not turn off</b>	6a- The thermostat is in continuous fan mode	6a- Press the Fan key to deactivate the continuous fan mode. Fan will now activate only with equipment.
<b>7 - Thermostat will not call for heat</b>	7a- Compressor delay still in progress	7a- Wait . . . equipment short cycle protection in progress. To override, press the UP and FAN buttons.
	7b- Thermostat temperature setpoint is satisfied	7b- Raise the heating temperature setpoint using the up arrow button.
<b>8 - Thermostat will not call for cooling</b>	8a- Compressor delay still in progress	8a- Wait . . . equipment short cycle protection in progress. To override, press the UP and FAN buttons.
	8b- Thermostat temperature setpoint is satisfied	8b- Lower the cooling temperature setpoint using the down arrow button.
<b>9 - Room Temperature too cool when set to cooling</b>	11a- Off-Cycle Dehumidification feature activated	11a- Deactivate Off-Cycle Dehumidification by following the instructions in this manual

# HEAT/COOL AUTO-CHANGEOVER NON-PROGRAMMABLE THERMOSTAT (PART #41-25347-01)

The non-programmable thermostat complements the programmable thermostat, but is less costly and has fewer features. Its location, mounting, installation, and wiring are the same as the programmable thermostat. However, it only displays the room temperature, the operating mode, and if heating or cooling is currently operating (see Figure 6).

This thermostat also can use remote indoor and outdoor sensors. No battery is needed. It can display temperatures in either °F or °C. It can run the blower continuously or intermittently. The user can select off-cycle dehumidification and multistaging features as desired.

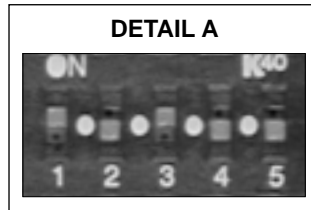
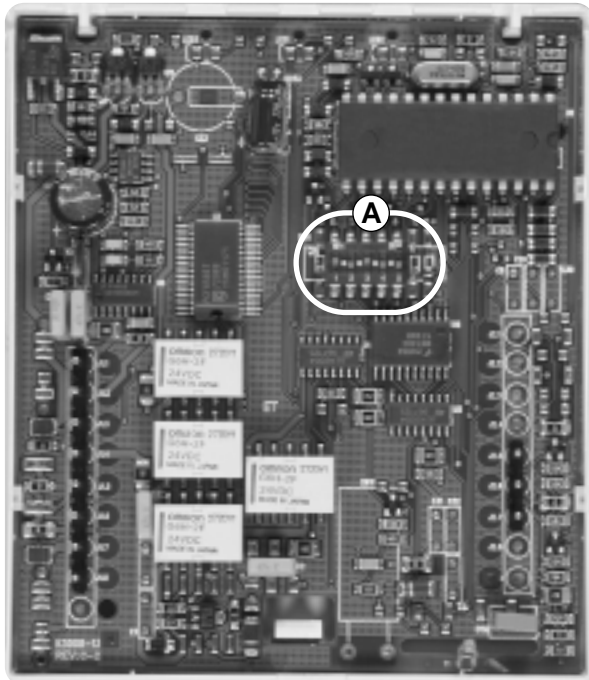
The user can select different temperatures for day and night settings. However, the thermostat must be manually changed from one to the other.

This thermostat has five DIP switches on the subbase. Only three of which are functional. The subbase and switch selections are illustrated (see Figure 7).

**FIGURE 6  
NON-PROGRAMMABLE  
THERMOSTAT**



**FIGURE 7  
NON-PROGRAMMABLE SUBBASE DIP SWITCH SETTINGS**



SWITCH #	OFF	ON
1	6 Minute Minimum On	4 Minute Minimum On
2	NOT USED	NOT USED
3	Humidity Control Off	Humidity Control On
4	NOT USED	NOT USED
5	Single-Stage	Multistage

## NON-PROGRAMMABLE THERMOSTAT INSTALLATION CONSIDERATIONS

You should prepare ahead if you are installing any of the options mentioned in other sections of this manual.

If this is a brand new installation or a replacement, verify:

- what kind of wire is needed or is present
- how much (distance from the thermostat and the equipment, and optional equipment )
- are you installing any remote sensing equipment (please read the installation instructions packaged with these units before proceeding any further)

The thermostat is to be connected using unshielded 18 AWG minimum thermostat wire.

## LOCATION

The most important consideration in installing your electronic thermostat is where to locate the unit. The location can radically affect the operation of the thermostat. To ensure proper operation, the thermostat should be mounted on an inside wall, in a frequently occupied area of the building. In addition, its position must be at least 18 inches (46cm) from any outside wall, and approximately 5 feet (1.5m) above the floor in a location with freely circulating air of an average temperature.

### BE SURE TO AVOID THE FOLLOWING LOCATIONS:

- behind doors or in corners where freely circulating air is unavailable
- where direct sunlight or radiant heat from appliances might affect control operation
- on an outside wall
- adjacent to, or in line with, conditioned air discharge grills, stairwells, or outside doors
- where its operation may be affected by steam or water pipes or warm air stacks in an adjacent partition space, or by an area not heated or cooled behind the thermostat
- where its operation will be affected by the supply air of an adjacent unit
- near sources of electrical interference such as arcing relay contacts

## THERMOSTAT INSTALLATION

### WARNING

**SHOCK HAZARD**  
Disconnect the power supply before any wiring connections or changes are made to prevent electrical shock or possible damage to the equipment. Follow all local electrical codes during installation. All wiring must conform to local and national electrical codes. Improper wiring or installation may damage this product, electrical shock, property damage or death.

### CAUTION

**EQUIPMENT DAMAGE HAZARD**  
Before connecting the power supply to finished installation, make all wiring connections and VERIFY all connections. Short-circuited or improperly connected wires will result in permanent damage to the unit and void the warranty.

**IMPORTANT: WHEN REPLACING AN EXISTING THERMOSTAT, USE WIRE TAGS TO IDENTIFY TERMINAL DESIGNATIONS AS YOU DISCONNECT THE UNIT.**

1. Lift the thermostat access cover and insert a coin (or a large flat blade screwdriver) into the slot located in the bottom center of the case and twist 1/4 turn. Be extremely careful not insert into the casing, as this may damage the circuit board. Grasp the lower corner of the thermostat body and separate from the thermostat backplate. Swing the thermostat out from the bottom, and lift up and out of the base.
2. Place the rectangular opening on the thermostat backplate over the equipment control wires protruding from the wall. Using the base as a template, mark the location of the two (2) mounting holes. No leveling is required.
3. Use the supplied anchors and screws for mounting on the drywall or plaster. Drill two (2) 3/16" (5mm) holes at the marked locations, tap nylon anchors flush to the wall surface. Fasten the backplate to the wall.
4. Connect the wires from your equipment to the thermostat terminal blocks as shown in Table 2 and Figures 8 and 9.

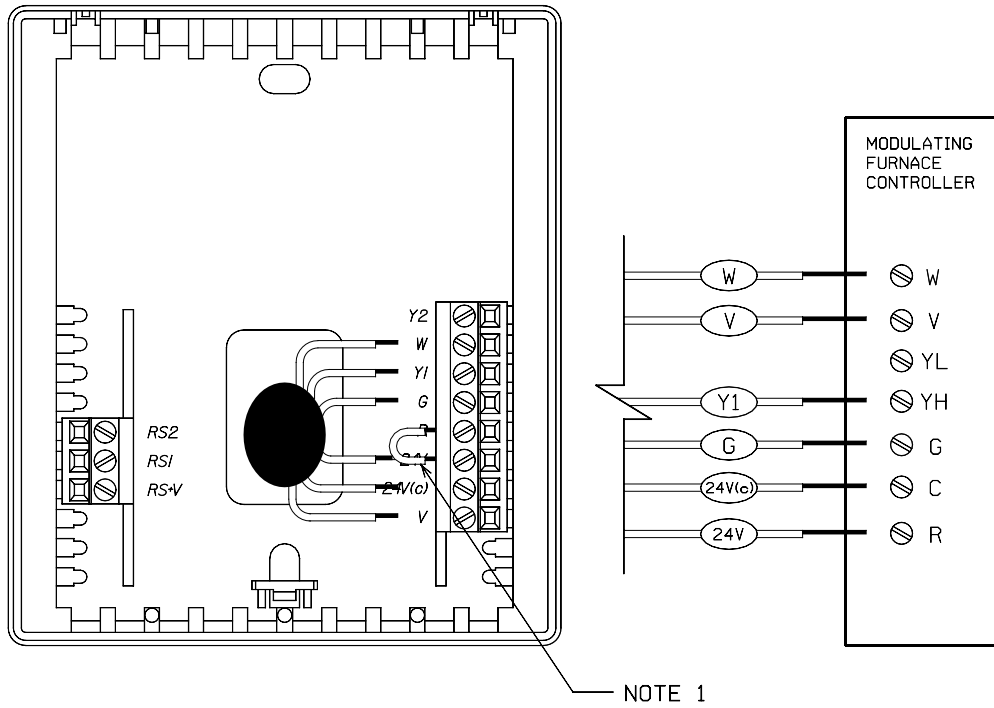
**TABLE 3**  
**OUTPUT TERMINAL DESIGNATIONS**

TERMINAL	FUNCTION
Y2	Energizes on a call for 2nd stage cooling
V	Modulating heat output
W	Energizes on a call for heat
Y1	Energizes on a call for cooling
G	Fan is energized with a call for heating or cooling, or pressing the Fan key on the thermostat
R *	Independent switching voltage (Typically jumpered to 24V)
24V *	24VAC from equipment transformer
24V(c)	24VAC Common from equipment transformer
RS2 RS1 RS+V	Use to connect outdoor temperature sensor (SL-ODT) option and / or indoor remote sensor(s) (SL-IDS) option. Refer to the instructions included with the sensors.



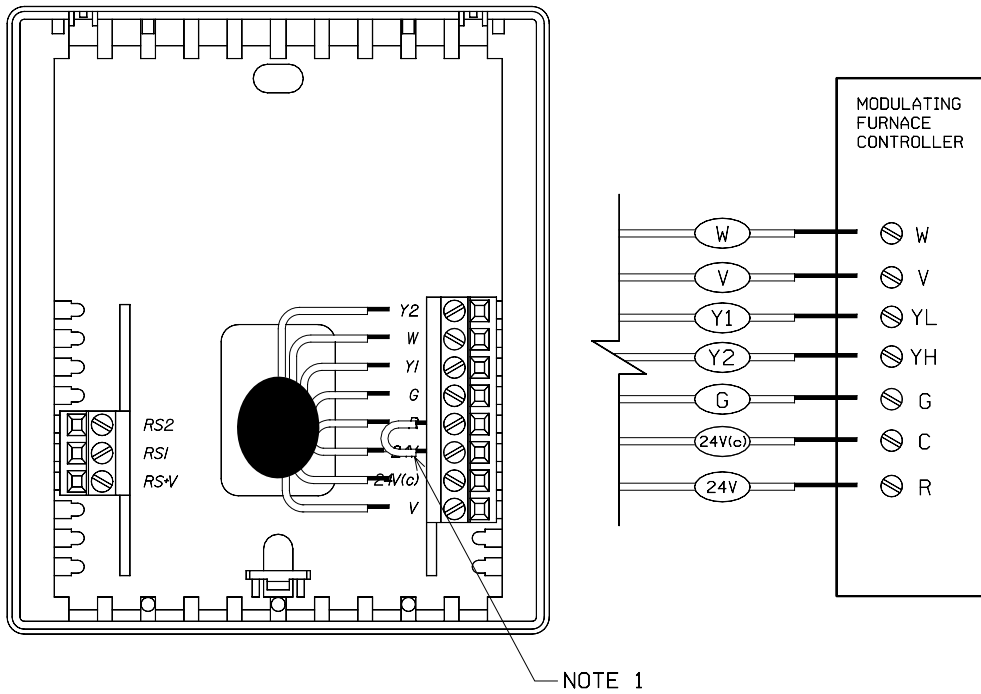
**FIGURE 8**  
WIRING DIAGRAM FOR MODULATING HEAT / 1 STAGE COOL

NOTE 1: INSURE JUMPER WIRE IS  
INSTALLED BETWEEN 24V AND "R".



**FIGURE 9**  
WIRING DIAGRAM FOR MODULATING HEAT / 2 STAGE COOL

NOTE 1: INSURE JUMPER WIRE IS  
INSTALLED BETWEEN 24V AND "R".



## RE-ASSEMBLING THE THERMOSTAT BODY AND ACCESS PANEL TO THE INSTALLED BACKPLATE

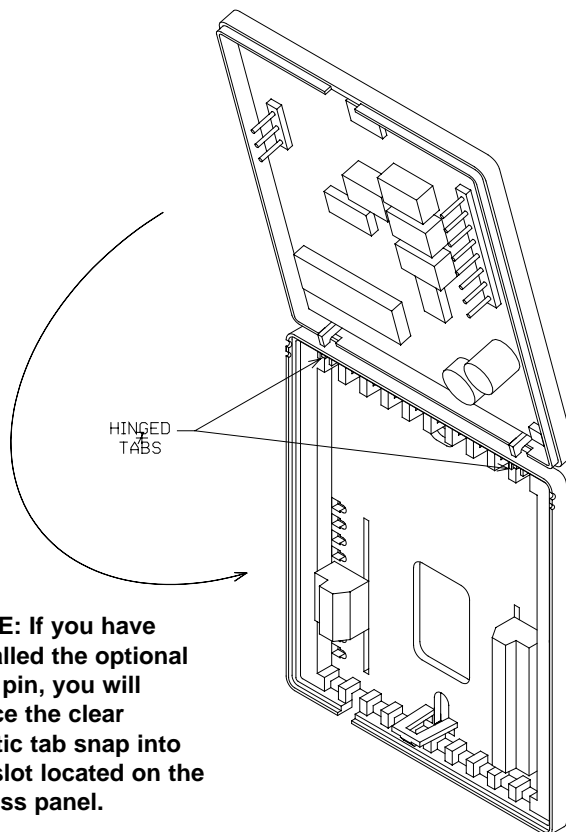
Before the thermostat is re-assembled to the backplate, install the optional indoor/outdoor remote sensors, if used. Refer to the installation instructions supplied with each option. Also, verify the positions of the DIP switches on the back of the thermostat body.

1. Position the thermostat inside the access panel. See Figure 10.
2. Position the assembly on the hinged tabs located at the top of the installed backplate.
3. Gently swing the thermostat and access cover downwards and press on the bottom center edge until it snaps into place.

## TEMPERATURE ACCURACY

Full temperature accuracy will only be realized after the thermostat has been installed and powered for at least one (1) hour.

**FIGURE 10**  
RE-ASSEMBLING THERMOSTAT TO BACKPLATE



## YOUR THERMOSTAT KEYS




The thermostat normally displays room temperature (°F or °C), mode of operation, and whether the fan is in use or not. The six keys on the front of the unit allow complete control of your heating and cooling equipment. This document will go into detail on the function of each of the ten keys. If you are already familiar with the thermostat, you need only refer to the pad-printed instructions located on the inside of the thermostat door.

You may select different heating and cooling setpoints for the system to maintain, e.g. 70° in heating and 75° in cooling. Raising or lowering the setpoints in heating or cooling is as simple as pushing a button. This section will describe the function of each of the keys which make up the thermostat's keyboard and walk you through setting up when (and why) you want your heating and cooling equipment to be activated.



### THE OUTDOOR KEY

This key allows the thermostat to display the outdoor temperature, if your thermostat has been installed with an optional electronic outdoor remote temperature sensor.

### THE MODE KEY

This key allows to select between the four (4) modes available: Heat , Cool , Auto , Off. The words (accompanied by their appropriate symbols) Heat, Cool, and Auto are displayed for five seconds. The words HEAT and Off remain visible.

### THE FAN KEY

This key allows to select between continuous fan mode or auto fan mode. The continuous fan mode constantly displays the  symbol; auto fan mode refers that the fan (and  symbol) only activates (is displayed) when your heating or cooling equipment has been activated.

### THE DAY/NIGHT KEY

This key switches the thermostat between day and night temperature settings.

### THE V AND ^ KEYS

When used with a combination of other keys, are used to scroll backward or forward through temperature setpoints). They can also choose between °C or °F. Press the V or ^ keys at the same time to change the temperature value from Celsius (°C) to Fahrenheit (°F), and vice versa.

## OPTIONAL FEATURES AND EQUIPMENT FOR NON-PROGRAMMABLE THERMOSTATS

The following are some of the options available for your electronic thermostat, to further enhance and expand its capabilities.

### THERMOSTAT ADAPTER PLATE (PART # 41-25300-01)

The thermostat adapter plate (See Figure 11) is used to mount your electronic thermostat over a large hole, or to cover other holes left by the previous thermostat if you are replacing an old thermostat. Simply drill out the holes marked "A", line the thermostat backplate holes with those already drilled out, and follow the standard installation instructions.

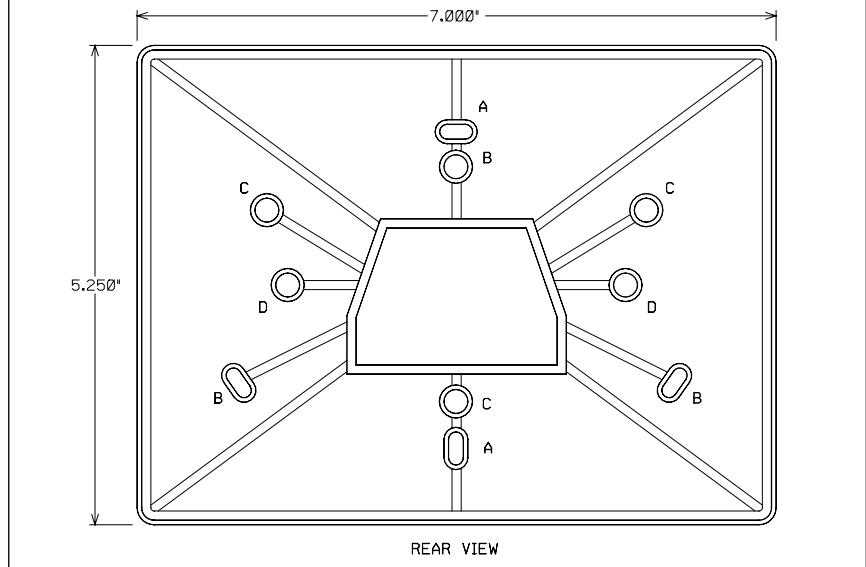
### REMOTE INDOOR TEMPERATURE SENSOR (PART # 41-25300-02)

The remote indoor sensor (See Figure 12) is designed for use with your electronic thermostat. It is easy to install and provides accurate digital communication of space temperature back to the controlling thermostat from up to 300 feet, using 3-wire unshielded cable (maximum of 100 feet if using shielded cable) wired directly to the thermostat (RS2, RS1, and RS+V). When a remote indoor sensor is installed, the on-board temperature sensor is disabled. The thermostat detects the remote sensor connection and controls temperature based on the data received. You may connect up to six (6) (and a optional remote outdoor temperature sensor) in daisy-chain for temperature averaging.

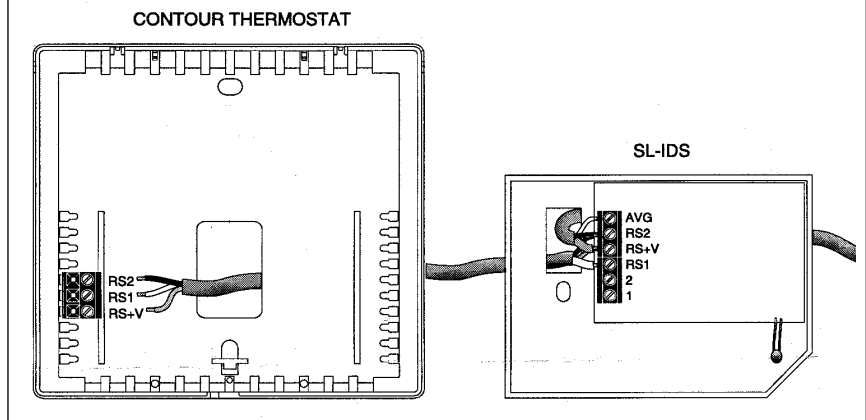
### OUTDOOR TEMPERATURE SENSOR (PART # 41-25300-03)

The remote outdoor sensor package (See Figure 13) is designed for use with the Contour Comfort Control thermostat. The sensor package is comprised of two (2) pieces: the indoor thermostat interface and the outdoor probe. It is easy to install and provides accurate digital communication of outdoor temperature back to the controlling thermostat from up to 300 feet, using 3-wire unshielded cable (maximum of 100 feet, if using shielded cable). There are no switches to set. The sensor may be connected directly to the electronic thermostat or wired directly to one of up to six optional indoor remote sensors.

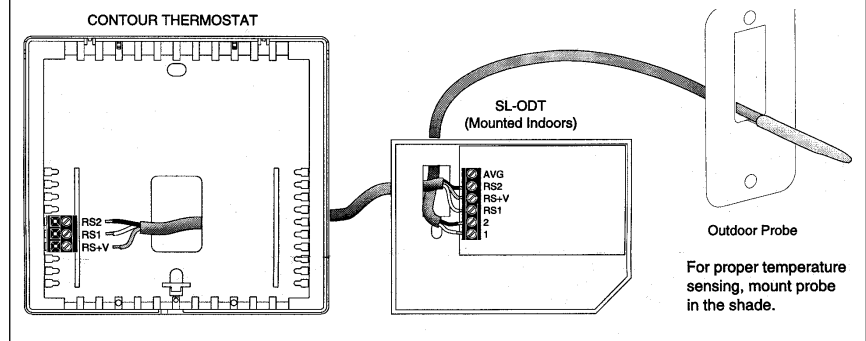
**FIGURE 11**  
THERMOSTAT ADAPTER PLATE



**FIGURE 12**  
REMOTE INDOOR TEMPERATURE SENSOR



**FIGURE 13**  
REMOTE OUTDOOR TEMPERATURE SENSOR PACKAGE



# NON-PROGRAMMABLE THERMOSTAT TROUBLESHOOTING GUIDE

This chapter is devoted to troubleshooting various operating problems that may occur. It suggests actions that may be taken to correct problems and return the thermostat to operational status.

To start troubleshooting procedure, a thorough visual inspection must be made to determine if the malfunction

is caused by some obvious defect (i.e., damaged component, loose wire connection, etc.)

Table 4 does not list all the symptoms and probable causes, only those most probable. Various combinations of malfunctions are also possible. The procedures are complete only up to being correctable.

<b>SYMPTOM</b>	<b>POSSIBLE CAUSE</b>	<b>CORRECTIVE ACTION</b>
<b>1- No display / faint display</b>	1a- Supply voltage incorrect	1a- Use a voltmeter to check between the 24V and 24V(c) terminals located on the thermostat backplate. Voltage should read between 20VAC to 30VAC. If the voltage is less than 20VAC, disconnect the thermostat and verify the voltage between 24V and the other equipment wires; see possible causes 1b and 1c. If voltage is greater than 30VAC, troubleshoot the power source and replace the thermostat.
	1b- System transformer weak or overloaded	1b- Check and / or replace with a suitable 24 V transformer
	1c- Thermostat damaged because system voltage was greater than 30VAC	1c- Replace with new thermostat, and ensure new thermostat is isolated from the system using suitable relays (INT-43) and a transformer of the proper rating.
<b>2- "AC" is on the LCD display</b>	2a- 20 - 30VAC absent from R and C terminals, located on the thermostat backplate	2a- Using a voltmeter, measure the voltage between the 24V and 24V(c) terminal blocks. If the reading is less than 20VAC, check system transformer. If the voltage is between 20 and 30VAC, replace the thermostat.
<b>3- LCD display has missing or extra segments displayed</b>	3a- LCD failure	3a- Replace the thermostat
<b>4- Temperature display is incorrect</b>	4a- The thermostat is set in either F or C display	4a- Verify whether the thermostat is set to display °C or °F.
	4b- Poor thermostat location	4b- Relocate the thermostat to a better location.
<b>5- Fan does not activate with the system equipment</b>	5a- Fan failure	5a- Place a jumper between terminal blocks R and G. Fan should activate. If it does not, troubleshoot the fan system; if fan does activate, replace the thermostat.
<b>6- Fan does not turn off</b>	6a- The thermostat is in continuous fan mode	6a- Press the Fan key to deactivate the continuous fan mode. Fan will now activate only with equipment.
<b>7- Thermostat will not call for heat</b>	7a- Compressor delay still in progress	7a- Wait . . . equipment short cycle protection in progress.
	7b- Thermostat temperature setpoint is satisfied	7b- Raise the heating temperature setpoint using the key.
<b>8- Thermostat will not call for cooling</b>	8a- Compressor delay still in progress	8a- Wait . . . equipment short cycle protection in progress.
	8b- Thermostat temperature setpoint is satisfied	8b- Lower the cooling temperature setpoint using the ... key.
<b>9- Minimum equipment ON time too long, causing overshoot</b>	9a- DIP switch #2 is in the ON position (manufacturer's default)	9a- Place DIP switch #2 to the ON position. This will decrease minimum equipment ON time from 6 minutes to 4 minutes.*
<b>10- Minimum equipment ON time too short</b>	10a- DIP switch #2 is in the OFF position	10a- Place DIP switch #2 to the OFF position. This will increase minimum equipment ON time from 4 minutes to 6 minutes.*
<b>11- Room Temperature too cool when set to cooling</b>	11a- Off-cycle dehumidification feature activated	11a- Place DIP switch #4 to the OFF position.





# USER'S INFORMATION MANUAL





# USER'S INFORMATION MANUAL FOR MODULATING CONDENSING GAS FURNACES

 Recognize this symbol as an indication of Important Safety Information!



## WARNING

IF THE INFORMATION IN THESE INSTRUCTIONS IS NOT FOLLOWED EXACTLY, A FIRE OR EXPLOSION MAY RESULT, CAUSING PROPERTY DAMAGE, PERSONAL INJURY OR DEATH.

## FOR YOUR SAFETY

- Do not store or use gasoline or other flammable vapors and liquids, or other combustible materials in the vicinity of this or any other appliance.
- WHAT TO DO IF YOU SMELL GAS
  - Do not try to light any appliance.
  - Do not touch any electrical switch; do not use any phone in your building.
  - Immediately call your gas supplier from a neighbor's phone. Follow the gas supplier's instructions.
  - If you cannot reach your gas supplier, call the fire department.
  - Do not rely on smell alone to detect leaks. Due to various factors, you may not be able to smell fuel gases.
  - U.L. recognized fuel gas and CO detectors are recommended in all applications, and their installation should be in accordance with the manufacturer's recommendations and/or local laws, rules, regulations, or customs.
- **Installation and service must be performed by a qualified installer, service agency or the gas supplier.**

**NOTE TO INSTALLER: REVIEW THIS MANUAL WITH THE USER AND LEAVE IT WITH THE EQUIPMENT.**

**DO NOT DESTROY. PLEASE READ CAREFULLY AND KEEP IN A SAFE PLACE FOR FUTURE REFERENCE.**

## WARNING

**PROPOSITION 65: THIS PRODUCT CONTAINS CHEMICALS KNOWN TO THE STATE OF CALIFORNIA TO CAUSE CANCER, BIRTH DEFECTS OR OTHER REPRODUCTIVE HARM.**

# INTRODUCTION TO YOUR FURNACE

Thank you for the purchase of your new modulating gas furnace! This furnace is designed to be the ultimate in heating comfort and is the only true modulating gas furnace available on the market today.

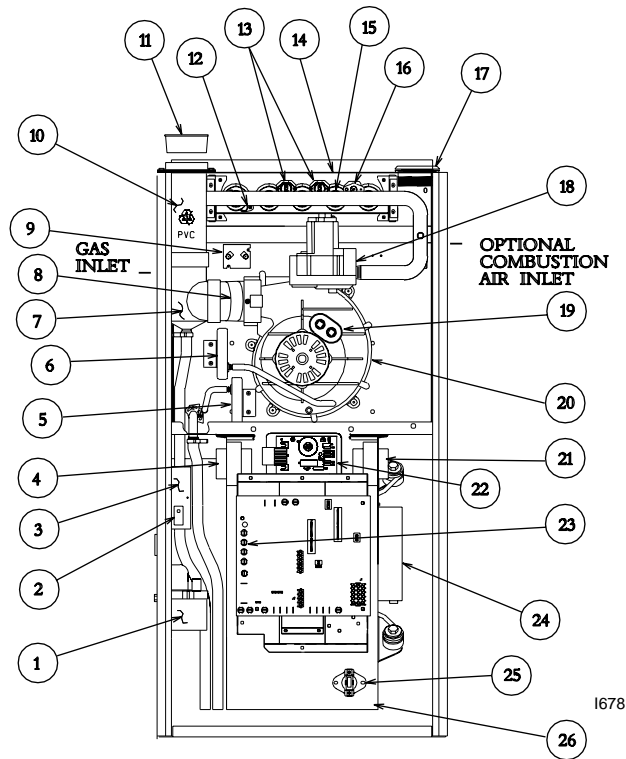
The modulating gas furnace provides a superior level of comfort due to the interaction of seven basic components:

- **Variable Output Thermostat** - Whereas conventional thermostats only send an On/Off signal to the furnace, the thermostat for the modulating furnace system is specially designed to indicate the exact heating requirements of the conditioned space. This is accomplished by a logic control routine that accurately senses the space load, minimizes recovery times, reduces temperature swings and optimizes system efficiency and performance.
- **Modulating Gas Valve** - The gas valve has the conventional redundant solenoid valves for inherent safety, but also has a third operator for capacity control. This operator is actually

a servo valve which varies the input rate of the furnace proportionally to the signal from the controller. The modulating furnace can operate anywhere from 40% to 100% of the nameplate input of the furnace.

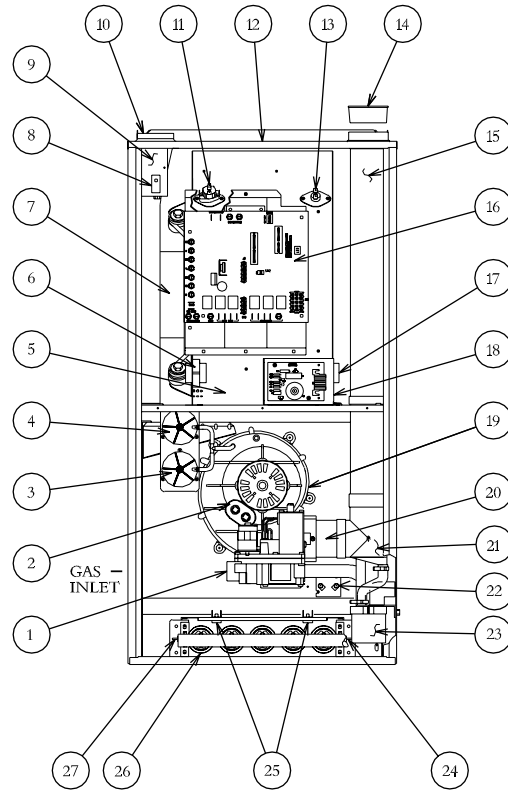
- **Furnace Controller** - The furnace controller provides all of the ignition and safety functions of the typical IFC as well as interpreting the signals from the thermostat. The furnace controller will optimize furnace performance by monitoring all thermostat and temperature inputs and insuring the stable operation of the inducer, gas valve and indoor blower motor.
- **ECM Variable Speed Blower** - The airflow through the duct work is varied to meet the load demand. Airflow as low as 300 CFM is achieved by the response of a brushless permanent magnet variable speed blower motor.
- **Two Speed Draft Inducer** - To insure clean combustion and peak efficiency, the induced draft motor speed is adjusted based on the gas valve setting to provide the proper amount of combustion air to the burners.

**FIGURE 1  
UPFLOW FURNACE**



ITEM NO.	PART NAME	ITEM NO.	PART NAME
1	CONDENSATE TRAP	14	TOP PLATE
2	DOOR SWITCH	15	BURNER
3	JUNCTION BOX	16	IGNITER
4	TRANSFORMER	17	COMBUSTION AIR INLET
5	LOW PRESSURE SWITCH	18	GAS VALVE
6	HIGH PRESSURE SWITCH	19	CAPACITOR
7	EXHAUST TRANSITION	20	INDUCED DRAFT BLOWER
8	CONNECTOR	21	POWER FACTOR CHOKE
9	MAIN LIMIT	22	IGNITION CONTROL
10	EXHAUST AIR PIPE	23	INTEGRATED FURNACE CONTROL
11	VENT CAP PLUG	24	BLOWER MOTOR
12	FLAME SENSOR	25	R/A SENSOR
13	OVERTEMPERATURE SWITCH	26	BLOWER HOUSING

**FIGURE 2  
DOWNFLOW FURNACE**



ITEM NO.	PART NAME	ITEM NO.	PART NAME
1	GAS VALVE	14	VENT CAP PLUG
2	CAPACITOR	15	EXHAUST AIR PIPE
3	LOW PRESSURE SWITCH	16	INTEGRATED FURNACE CONTROL
4	HIGH PRESSURE SWITCH	17	TRANSFORMER
5	BLOWER HOUSING	18	IGNITION CONTROL
6	POWER FACTOR CHOKE	19	INDUCED DRAFT BLOWER
7	BLOWER MOTOR	20	CONNECTOR
8	DOOR SWITCH	21	EXHAUST TRANSITION
9	JUNCTION BOX	22	MAIN LIMIT
10	COMBUSTION AIR INLET	23	CONDENSATE TRAP
11	HALC	24	IGNITER
12	TOP PLATE	25	OVERTEMPERATURE SWITCH
13	RETURN AIR SENSOR	26	BURNER
		27	FLAME SENSOR

• *Return and Supply Air Sensors* - These two thermister assemblies, a factory installed return air sensor and a field installed air probe, communicate the furnace temperature rise to the integrated furnace control. The integrated furnace control uses this information to calculate field conditions during calibration to insure optimal efficiency and comfort during normal operation.

This furnace has been designed to give you many years of efficient, dependable home comfort. With regular maintenance,

this furnace will operate superbly year after year. Please take the time to fill out the information below and read this manual to familiarize yourself with operation, maintenance schedule, and safety operation.

**IMPORTANT: READ THESE INSTRUCTIONS THOROUGHLY BEFORE ATTEMPTING TO OPERATE THIS FURNACE.**

## INSTALLATION INFORMATION

Date Installed \_\_\_\_\_

Dealer Name \_\_\_\_\_

Address \_\_\_\_\_

City \_\_\_\_\_

State \_\_\_\_\_ Zip \_\_\_\_\_

Telephone No. \_\_\_\_\_

## AC SYSTEM

Model No. \_\_\_\_\_

Serial No. \_\_\_\_\_

## INDOOR COIL

Model No. \_\_\_\_\_

Serial No. \_\_\_\_\_

## FURNACE

Model No. \_\_\_\_\_

Serial No. \_\_\_\_\_

## SAFETY PRECAUTIONS SIGNAL WORDS

There are some safety precautions which must be understood and followed by all users of equipment such as your furnace, where flames, gas, electricity and rotating parts are present. To alert you to the above potential hazards, we use the signal words "WARNING" and "CAUTION" throughout this manual and safety labels attached to the furnace.

Read carefully and pay special attention to all warnings and cautions in this manual. They are defined and designed as follows to help you recognize and avoid the potential hazards of operating this furnace:

**▲ WARNING**

Indicates a potentially hazardous situation which, if not avoided, could result in property damage, serious injury or death.

**▲ CAUTION**

Indicates a potentially hazardous situation which, if not avoided, could result in property damage, or minor or moderate injury.

## POSSIBILITY OF FIRE OR EXPLOSION

**▲ WARNING**

THIS FURNACE OPERATES BY BURNING GAS INSIDE YOUR HOME. THIS CREATES THE POSSIBILITY OF FIRE OR AN EXPLOSION WHICH CAN RESULT IN PROPERTY DAMAGE, PERSONAL INJURY OR DEATH. YOU MUST READ AND FOLLOW ALL OF THESE SAFETY PRECAUTIONS TO HELP ENSURE SAFE OPERATION OF YOUR FURNACE.

- Do not test for gas leaks with a match or flame.
- Do not use this furnace with any other gas than the one listed on the rating plate.
- Follow the furnace lighting instructions carefully to be sure all gas fumes are cleared before lighting the furnace.
- Check carefully for gas before lighting a furnace. Do not rely on smell alone to detect gas. Use a UL recognized fuel gas detector and a soap and water solution on the pipes to check for gas leaks.
- A damaged gas control knob can cause gas to leak. Do not hit or damage the knob. Do not force the knob with tools. Use only your hand to turn it to "ON" or "OFF". Call the a quali-

fied installer, service agency or the gas supplier immediately if you have problems turning the knob.

- Should overheating occur, or the gas valve fail to shut off the gas supply, turn off the manual gas valve to the furnace before turning off the electrical supply.
- Soot buildup indicates a serious combustion problem that requires immediate correction. Turn the gas supply "OFF" until the furnace is repaired. Contact a qualified installer, service agency or the gas supplier immediately to inspect the furnace.
- Do not place, store or use gasoline or other flammable vapors and liquids on, against, or around the furnace jacket.
- Do not store combustible materials near the furnace. The furnace must have adequate clearances from all combustible materials such as clothing, paper, cardboard, wood or cleaning materials to prevent them from igniting.
- Keep any furnace installed in an attic or other insulated space free and clear of insulating material. Examine the furnace area when installing the furnace or adding insulation. Some materials may be combustible.
- Any additions, changes or conversions required in order for the furnace to satisfactorily meet the application needs should be made by a qualified installer, service agency or the gas supplier, using factory specified or

approved parts. Read your Warranty. Contact the WARRANTOR for conversion information. This furnace was equipped at the factory for use on NATURAL GAS ONLY. Conversion to LP GAS requires a special kit supplied by the WARRANTOR.

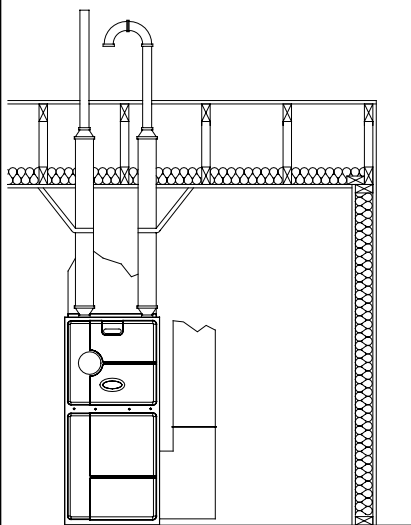
## DANGER FROM ASPHYXIATION

### ▲ WARNING

THIS FURNACE OPERATES BY BURNING GAS INSIDE YOUR HOME. IMPROPER OR INCOMPLETE BURNING OF THIS GAS CAN RESULT IN THE FORMATION OF CARBON MONOXIDE. IF INTRODUCED INTO THE LIVING SPACE, THIS CAN CAUSE DIZZINESS, NAUSEA, OR DEATH BY ASPHYXIATION. YOU MUST READ AND OBSERVE THE SAFETY RULES BELOW TO PREVENT OXYGEN DEPLETION OR UNBURNED GAS OR COMBUSTION FROM ESCAPING INTO THE LIVING SPACE OF YOUR RESIDENCE.

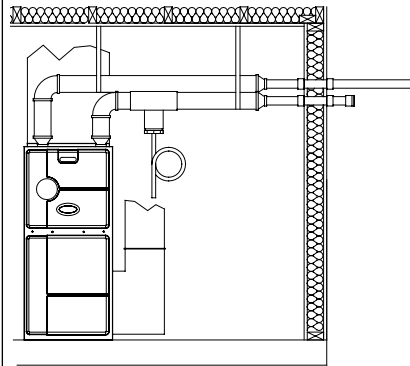
- Do not operate this furnace without provisions for an adequate combustion air supply.
- Do not allow snow, ice, or any other debris to accumulate in or around the exhaust and intake terminations of this furnace. These are extended through the roof or horizontally through the sidewall of the structure. See Figures 3 & 4. Blockage of the intake and exhaust can result in inad-

**FIGURE 3**  
STANDARD VERTICAL  
DIRECT VENTING



1407

**FIGURE 4**  
STANDARD HORIZONTAL  
DIRECT VENTING



1407

equate combustion air as well as inadequate unit performance or nuisance tripping.

- Prevent flue gases from escaping into your residence. Deterioration of the venting system, or soot build-up can cause leaks into the system. Have a qualified installer, service agency or the gas supplier replace damaged parts or repair obstructions in a deteriorated vent system immediately.
- Do not use this furnace if any part has been under water. A flood-damaged furnace is extremely dangerous. Attempts to use the furnace can result in fire or explosion. A qualified service agency should be contacted to inspect the furnace and to replace all gas controls, control system parts, electrical parts that have been wet or the furnace, if deemed necessary.
- To prevent carbon monoxide poisoning, all blower doors and compartment covers must be replaced after the furnace is serviced. Do not operate the unit without all panels and doors securely in place.

## SYSTEM OPERATION INFORMATION

- Keep the air filters clean. Your heating system will operate more efficiently and provide better heating, more economically.
- Arrange your furniture and drapes so that the supply air registers and return air grilles are unobstructed.
- Close doors and windows. This will reduce the heating load on your system.
- Avoid excessive use of exhaust fans.
- Do not permit the heat generated by television, lamps, or radios to influence the thermostat operation.

- If you desire to operate your system with constant air circulation, consult your thermostat manual or please ask advice from a qualified installer, service agency or the gas supplier.

**IMPORTANT:** FOR COMPLETE OPERATION AND SET UP OF YOUR THERMOSTAT REFER TO THE MANUAL INCLUDED IN THE LITERATURE PACKET SHIPPED WITH THIS FURNACE.

## STARTING YOUR FURNACE

### LIGHTING INSTRUCTIONS

This appliance is equipped with a direct spark ignition device. This device lights the main burners each time the room thermostat calls for heat. **DO NOT** try to light the burner by hand. See lighting instructions on the furnace.

1. Remove the burner access door.
2. Set the thermostat to the lowest setting.
3. Turn the gas control knob counterclockwise to the "ON" position.
4. Replace the burner access door.
5. Turn on the electrical power.
6. Set the room thermostat to a point above the room temperature to light the main burners. After the burners are lit, set the room thermostat to a desired temperature.

### ▲ WARNING

BE SURE THAT THE MANUAL GAS CONTROL HAS BEEN IN THE "OFF" POSITION FOR AT LEAST FIVE MINUTES. DO NOT ATTEMPT TO MANUALLY LIGHT THE MAIN BURNERS. FAILURE TO FOLLOW THIS WARNING CAN CAUSE A FIRE OR AN EXPLOSION RESULTING IN PROPERTY DAMAGE, PERSONAL INJURY OR DEATH.

7. If the appliance will not operate, follow the instructions "To Turn Off Gas To The Appliance" and call your service technician or gas supplier.

## TO TURN OFF GAS TO THE APPLIANCE

### **▲ WARNING**

SHOULD OVERHEATING OCCUR OR THE GAS SUPPLY FAIL TO SHUT OFF, SHUT OFF THE MANUAL GAS VALVE TO THE APPLIANCE BEFORE SHUTTING OFF THE ELECTRICAL SUPPLY. FAILURE TO DO SO CAN CAUSE AN EXPLOSION OR FIRE RESULTING IN PROPERTY DAMAGE, PERSONAL INJURY OR DEATH.

**IMPORTANT:** SHUT OFF THE MANUAL GAS VALVE LOCATED IN THE GAS SUPPLY PIPING OUTSIDE THE FURNACE CASING.

1. Set the thermostat to the lowest setting.
2. Turn off all electric power to the appliance on which service is to be performed.
3. Remove the burner access door.
4. Turn the gas control knob to the "OFF" position.
5. Replace the burner access door.

## SEQUENCE OF OPERATION

### **Heating Cycle Initiation**

The heating cycle is always initiated by a 24 volt signal on W of the thermostat. When the controller senses 24 volts on W, the following sequence occurs:

- High and low pressure switches are checked to insure contacts are open.
- Inducer is powered on high speed for a thirty (30) second prepurge.
- Pressure switches are monitored as the inducer creates the vacuum to close the contacts.
- The servo valve on the gas valve is energized with ~180 milliamps current. (No flow yet.)
- The controller sends 120 volts to the ignition control, which sparks across the electrodes.
- The main solenoids on the gas valve are energized allowing gas to flow to the burners.
- When flame is proven, the ignition control is de-energized - 8 second maximum trial time.
- The gas valve maintains 100% rate through the warm-up period - 20 seconds.

### **Heating Cycle Response**

The heating cycle is always initiated by a 24 volt signal on W1. When the controller senses 24 volts on W1, the following sequence occurs:

### **MODULATING FUNCTION:**

("W" and "V" signal inputs)

After the warm-up period, the furnace will respond to the thermostat demand by adjusting the gas valve pressure and blower speed anywhere between 40% to 100% heating capacity.

### **TWO-STAGE FUNCTION:**

("W" and "W2" inputs)

After the warm-up period, the furnace will respond to the thermostat demand by adjusting the gas valve pressure and blower heating speeds to the W signal values. "W" only = 40% gas valve pressure and blower heating speed. "W" and "W2" = 100% gas valve pressure and blower heating speed.

### **SINGLE-STAGE**

("W" signal only)

After the warm-up period, the furnace will respond to the thermostat demand by maintaining the gas valve pressure and blower speed at 100%.

### **Heating Cycle Termination**

When the 24 volt signal is removed from W1, the heating cycle will end and the furnace will shut down and return to the proper off cycle operation.

## MAINTENANCE

**IMPORTANT:** IT IS RECOMMENDED THAT AN ANNUAL INSPECTION OF YOUR FURNACE BE MADE BY A QUALIFIED INSTALLER, SERVICE AGENCY OR THE GAS SUPPLIER. DURING THE ANNUAL INSPECTION, IT IS RECOMMENDED THAT 120VAC POWER BE TURNED OFF, THEN BACK TO THE ON POSITION. REAPPLYING 120VAC INITIATES A CALIBRATION CYCLE TO ENSURE OPTIMUM SYSTEM OPERATION.

### **▲ WARNING**

THIS FURNACE CONTAINS MOVING/ROTATING COMPONENTS AND USES HOUSEHOLD ELECTRICAL CURRENT. FOLLOW THE SAFETY RULES BELOW TO AVOID CUTS, BURNS OR ELECTRICAL SHOCK WHICH CAN RESULT IN SEVERE PERSONAL INJURY OR DEATH.

## POSSIBILITY OF BURNS OR ELECTRICAL INJURY

- Do not perform any service or maintenance on the furnace while it is operating. Read and follow the service instructions provided with this furnace before beginning any service or maintenance work.
- Do not open the blower compartment, disassemble, or remove any components while the furnace is operating. This may expose sharp edges or points which could cause cuts, hot surfaces which could cause burns, and electrical circuits which could cause shocks.
- Instruct children on the safety hazards associated with furnaces. Keep children away from the furnace at all times.

## FILTER MAINTENANCE

### **▲ CAUTION**

DO NOT OPERATE YOUR SYSTEM FOR EXTENDED PERIODS WITHOUT FILTERS. A PORTION OF THE DUST ENTRAINED IN THE AIR MAY TEMPORARILY LODGE IN THE AIR DUCT RUNS AT THE SUPPLY REGISTERS. ANY RECIRCULATED DUST WILL BE HEATED AND CHARRED BY CONTACT WITH THE FURNACE HEAT EXCHANGER. THIS RESIDUE WILL SOIL CEILINGS, WALLS, DRAPES, CARPETS AND OTHER HOUSEHOLD ARTICLES.

Have your qualified installer, service agency or the gas supplier instruct you on how to access your filters for regular maintenance.

- Keep air filters clean at all times. Vacuum dirt from filter, wash with detergent and water, air dry thoroughly and reinstall.
- After filters are cleaned and returned to the furnace, be sure doors are properly reinstalled. If you are not totally sure of this procedure, consult qualified installer, service agency or the gas supplier.

## REMOVING FILTERS

### FILTER IN BOTTOM OR SIDE LOCATION

1. Remove the blower compartment access door.
2. Disengage the filter retaining rod and pull filter out.
3. Clean filter and reinstall.
4. Replace the blower compartment access door.

## LUBRICATION

The blower motor and induced draft motor are permanently lubricated by the manufacturer and do not require further attention.

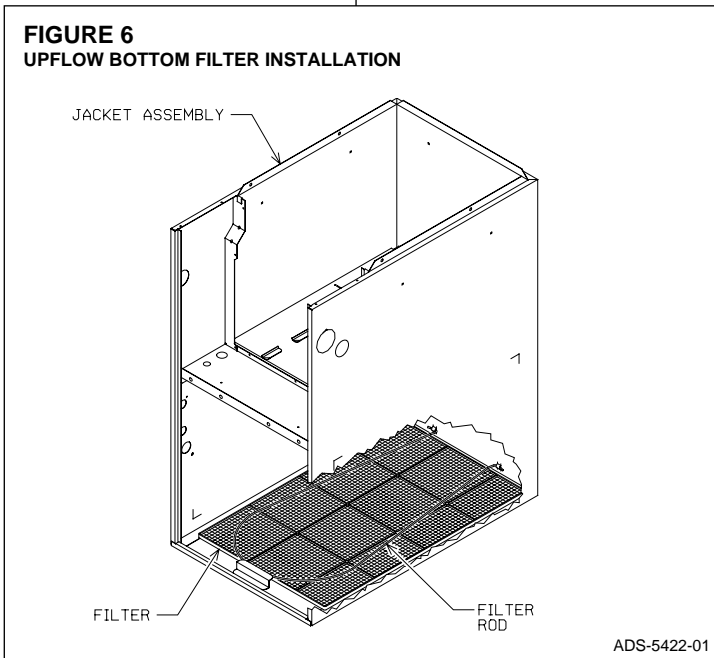
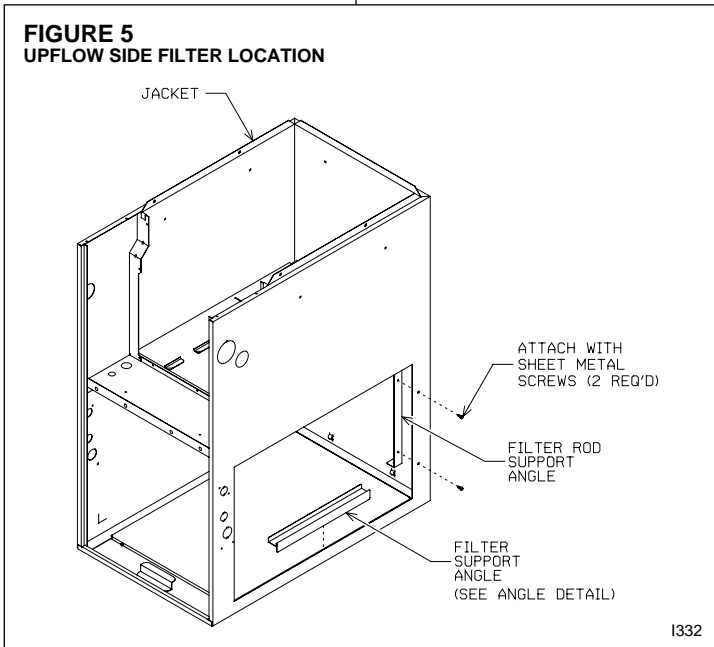
**IMPORTANT: DO NOT ATTEMPT TO LUBRICATE THE BEARINGS ON THE BLOWER MOTOR OR THE INDUCED**

**DRAFT BLOWER MOTOR. ADDITION OF LUBRICANTS CAN REDUCE THE MOTOR LIFE AND VOID THE WARRANTY.**

The blower compartment and motor should be inspected and cleaned periodically by your qualified installer, service agency or the gas supplier to prevent the possibility of overheating due to an accumulation of dust and dirt on the windings or on the motor exterior. And, as suggested elsewhere in these instructions, keep the air filters clean because dirty filters can restrict airflow and the motor depends on sufficient air flowing across and through it to keep it from overheating.

## COMBUSTION AIR AND VENT SYSTEM

1. It is recommended that an annual inspection of your furnace's combustion air and vent system be done by a qualified installer, service agency or the gas supplier.



### ▲ WARNING

IF DIRT, RUST, SOOT OR SCALE ACCUMULATIONS ARE PRESENT, DO NOT OPERATE THE FURNACE. INSPECT THE HEAT EXCHANGER FOR LEAKS. LEAKS CAN CAUSE TOXIC FUMES TO ENTER THE HOME AND CAUSE CARBON MONOXIDE POISONING OR DEATH.

2. Turn OFF the electrical supply to the furnace and remove the access doors.
3. Inspect the gas burners for dirt, rust or scale and clean as necessary.
4. Inspect the flue connection area and vent pipe. Be sure that the vent connector is in place and slopes upward and is physically sound, without holes or excessive corrosion.
5. Be sure that the return air duct connections are physically sound, are sealed to the furnace casing and terminate outside the space containing the furnace.

### ▲ WARNING

CHECK THE VENT PIPE SECTIONS FOR DETERIORATION AND CHECK JOINT FITTINGS FOR THEIR INTEGRITY. IF IT HAS BECOME DISCONNECTED TOXIC FUMES CAN ENTER THE HOME AND CAUSE CARBON MONOXIDE POISONING OR DEATH. DO NOT OPERATE THIS FURNACE. APPROPRIATE SERVICE MUST BE APPLIED.

6. Be sure the physical support of the furnace is sound, without sags, cracks, etc. around the base so as to provide a seal between the support and the base.
7. Look for the obvious signs of deterioration of the furnace.
8. If the furnace is free of the above conditions, replace the access doors and restore electrical power to the furnace.
9. Start the furnace and observe its operation. Watch the burner flames to see if they are bright blue. If a suspected malfunction is observed, or the burner flames are not bright blue, call for appropriate service.

## CONDENSATE

This furnace is equipped with a pressure switch which will shut off the main burners if the condensate drain line becomes blocked.

Be sure this condensate drain line does not become blocked or plugged. Visual inspection of the condensate flow can easily be made while the furnace is in operation. Use a flashlight to illuminate the discharge end placed in the sewer opening. See Figures 8 & 9.

Clean and flush the condensate tube to make sure condensate flows freely while the furnace is in operation.

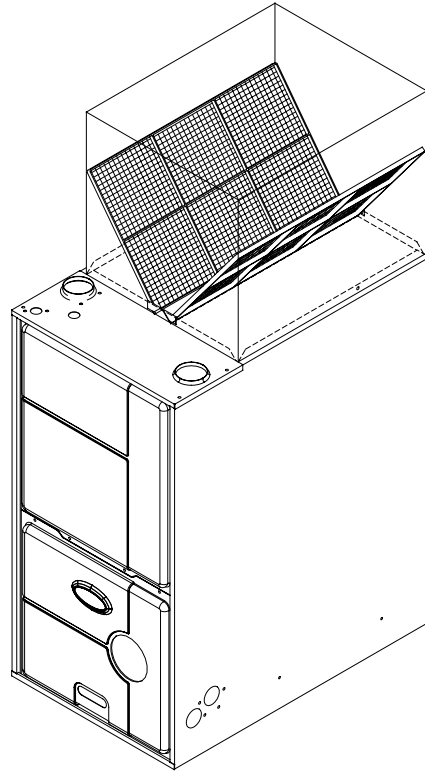
**IMPORTANT: IT IS RECOMMENDED THAT AT THE BEGINNING OF THE HEATING SEASON, THE CONDENSATE TRAP BE INSPECTED BY A QUALIFIED INSTALLER, SERVICE AGENCY OR THE GAS SUPPLIER FOR DEBRIS OR BLOCKAGE. A BLOCKED CONDENSATE TRAP CAN CAUSE WATER TO BACK UP INTO THE PRIMARY HEAT EXCHANGER AND LEAD TO NUISANCE TRIPPING OF THE OVER TEMPERATURE SWITCHES OR PRESSURE SWITCHES.**

**IMPORTANT: IT IS RECOMMENDED THAT AT THE BEGINNING OF THE HEATING SEASON THE CONDENSATE NEUTRALIZER, IF USED, BE REPLACED BY A QUALIFIED INSTALLER, SERVICE AGENCY OR THE GAS SUPPLIER.**

## MARKINGS

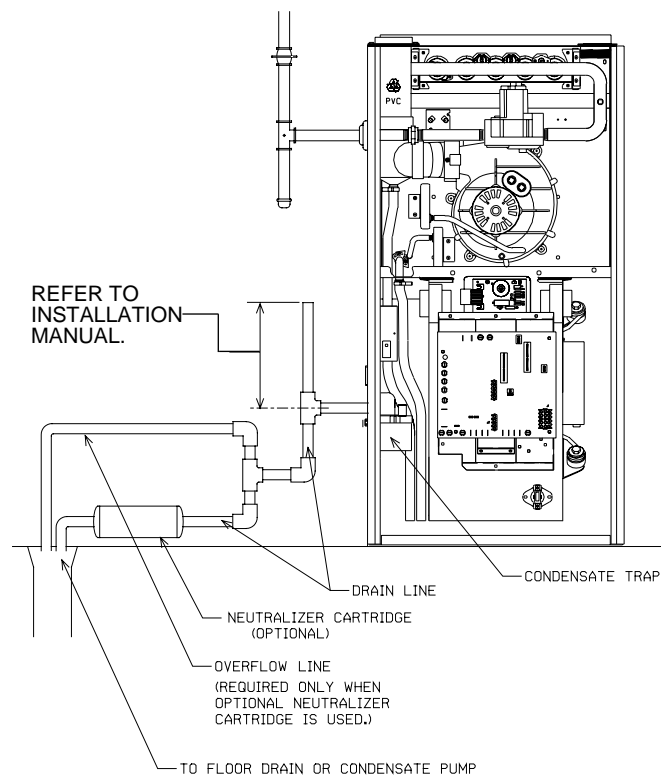
It is recommended that an annual inspection and cleaning of all furnace markings be made to assure legibility. Attach a replacement marking, which can be obtained through the distributor, if any are found to be illegible or missing.

**FIGURE 7  
DOWNFLOW FILTER INSTALLATION**



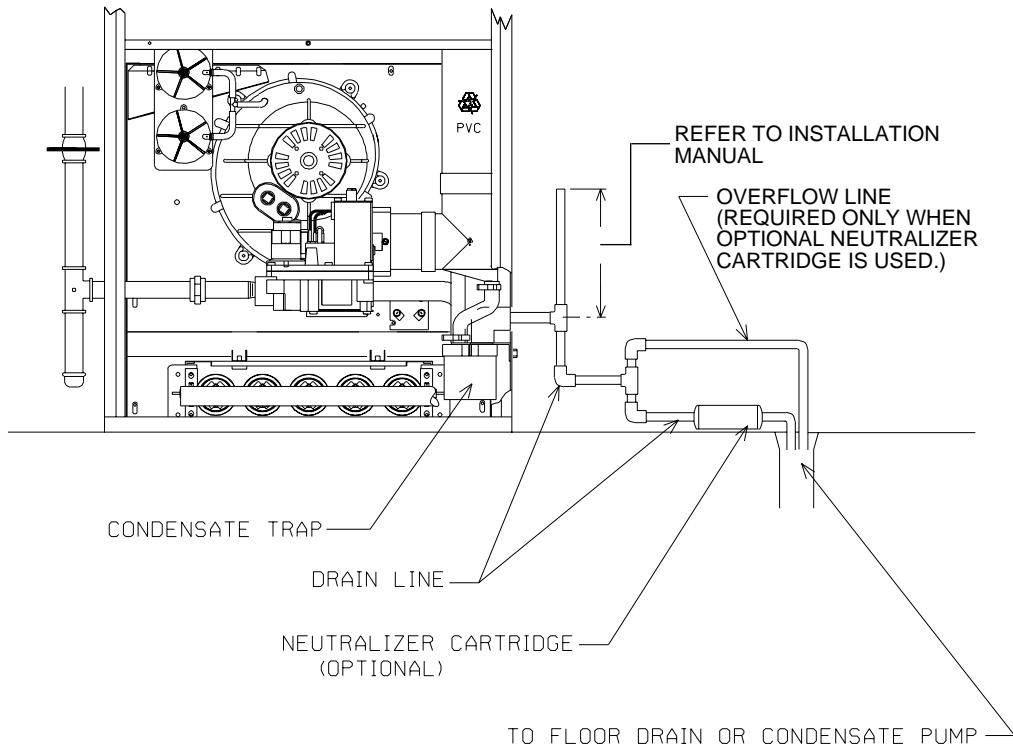
A087001.S01

**FIGURE 8  
UPFLOW CONDENSATE DRAIN**



A051601

**FIGURE 9**  
**DOWNFLOW CONNECTION**



A0850-01